



## Woodbury County Law Enforcement Center Authority

---

Ron Wieck, Chair  
Dan Moore, Secretary  
Mark Nelson, Treasurer

Woodbury County Courthouse  
620 Douglas Street, Room #104  
Sioux City, Iowa 51101  
712.279.6525

### AGENDA

**Tuesday, February 13, 2024**

#### **First Floor Boardroom, Woodbury County Courthouse**

2:00P

Call the meeting to order

1. Approval of the agenda
2. Approval of meeting minutes from January 30, 2024
3. Approval of claims
4. Financial Report – Dennis Butler
5. Statement from the LEC Authority Chairman Ron Wieck
6. Discussion & approval for hiring a scheduling/damage expert – Shane Albrecht (Baker Group)
7. Discussion & approval for hiring a mechanical expert – Shane Albrecht (Baker Group)
8. Discussion & vote on using LEC maintenance funds for an FY2025 maintenance budget provided by Woodbury County Building Services Director Kenny Schmitz – Mark Nelson
9. Discussion & approval of PCO's 86R2, 109R3, 121, & 122R – Shane Albrecht (Baker Group)
10. Discussion & approval of PCCO 023 – Shane Albrecht (Baker Group)
11. Information & update on the LEC project – Shane Albrecht (Baker Group)
12. Public concerns
13. Authority Board Members concerns
14. Closed session @ 2:45P with Fredrikson & Byron Law Firm (Iowa Code Chapter 21.5(1)(c))
15. Joint Closed session @ 3:15P with Woodbury County Board of Supervisors (Iowa Code Chapter 21.5(1)(c))
16. Adjourn

# *Woodbury County Law Enforcement Center Authority*

## **Minutes**

January 30, 2024, 2:00 p.m.

First Floor Boardroom, County Courthouse

Attendance:

Members: Ron Wieck, Mark Nelson

Staff: Karen James, Administrative Assistant, Dennis Butler, Finance Director, Shane Albrecht, Baker Group, Kenny Schmitz, Building Services, Kevin Rost, Goldberg Group Architect, Jodie McDougal, Attorney by phone

1. Motion by Wieck, second by Nelson to approve the agenda. Carried 2-0
2. Motion by Nelson second by Wieck to approve the minutes of January 16, 2024, meeting. Carried 2-0
3. Motion by Nelson second by Wieck to approve claims totaling \$57,362.95. Carried 2-0
4. Dennis Butler, Finance Director and Shane Albrecht, Baker Group gave an update on the financial report.
5. Mark Nelson discussed the LEC Authority covering year one maintenance for the LEC facility.
6. Motion by Nelson, second by Wieck to approve Law Enforcement Center dedication plaque. Carried 2-0
7. MidAmerican Energy presented a rebate check for \$149,078.00 to the LEC Authority.
8. Motion by Nelson, second by Wieck to approve PCO 113 for credit amount of \$250,000.00. Carried 2-0
9. Motion by Nelson, second by Wieck to approve PCCO 022 for credit amount of \$242,972.00. Carried 2-0
10. Shane Albrecht, Baker Group gave information and update on the LEC project.
11. No public concerns.
12. Chairman Wieck gave an update on what he and Shane Albrecht do on a weekly basis.  
  
Mark Nelson discussed phone calls he receives from citizens and their concerns.
13. Motion by Wieck, second by Nelson to go into closed session per Iowa Code 21.5 (1) (c) with Fredrikson & Byron Law Firm. Carried 2-0 on a roll-call vote.

Motion by Nelson, second by Wieck to go out of closed session per Iowa Code 21.5(1) (c) with Fredrikson & Byron Law Firm. Carried 2-0 on a roll-call vote.

14. Motion by Wieck, second by Nelson to go into closed session per Iowa Code 21.5 (1) (c) with Woodbury County Board of Supervisors and Fredrikson & Byron Law Firm. Carried 2-0 on a roll-call vote.

Motion by Wieck, second by Nelson to go out of closed session per Iowa Code 21.5(1) (c) with Woodbury County Board of Supervisors and Fredrikson & Byron Law Firm. Carried 2-0 on a roll-call vote.

15. Motion by Wieck, second by Nelson to adjourn the meeting.

---

Dan Moore, Secretary



Woodbury County

# Expense Approval Report By Segment (Select Below)

Post Dates 2/13/2024 - 2/13/2024

Vendor Name	Account Number	Payable Number	Description (Item)	Post Date	Amount
<b>Office: 45 - Law Enforcement Authority</b>					
Goldberg Group Architects	0005-45-9111-000-61005	1129	0005 - Jail project - Reimbursa...	02/13/2024	1,251.65
Goldberg Group Architects	0005-45-9111-000-61013	1129	0005 - Jail project - Reimbursa...	02/13/2024	320.31
Hausmann Construction, Inc.	0005-45-9111-000-61003	21-068-030	0005 - Jail project - Constructi...	02/13/2024	120,365.44
Hausmann Construction, Inc.	0005-45-9111-000-61013	21-068-030	0005 - Jail project - Contingen...	02/13/2024	22,302.20
Hausmann Construction, Inc.	0005-45-9111-000-61023	21-068-030	0005 - Jail project - Alternates	02/13/2024	12,987.27
Baker Group	0005-45-9111-000-61013	262325	0005 - Jail project - project m...	02/13/2024	34,000.00
Baker Group	4753-45-9111-000-61004	262796	4753 - Jail project - Meetings ...	02/13/2024	3,806.25
<b>Office 45 - Law Enforcement Authority Total:</b>					<b>195,033.12</b>
<b>Grand Total:</b>					<b>195,033.12</b>

## Report Summary

### Fund Summary

Fund	Expense Amount	Payment Amount
0005 - America Rescue Plan Act	191,226.87	0.00
4753 - Justice Center Miscellaneous Revenue	3,806.25	0.00
<b>Grand Total:</b>	<b>195,033.12</b>	<b>0.00</b>

### Account Summary

Account Number	Account Name	Expense Amount	Payment Amount
0005-45-9111-000-61003	Construction	120,365.44	0.00
0005-45-9111-000-61005	Reimbursables	1,251.65	0.00
0005-45-9111-000-61013	Contingency/Change Or...	56,622.51	0.00
0005-45-9111-000-61023	Construction Alternates	12,987.27	0.00
4753-45-9111-000-61004	Misc/Administration	3,806.25	0.00
<b>Grand Total:</b>		<b>195,033.12</b>	<b>0.00</b>

### Project Account Summary

Project Account Key	Expense Amount	Payment Amount
4753-9111-MISC/ADMIN	3,806.25	0.00
ARPA 2	191,226.87	0.00
<b>Grand Total:</b>	<b>195,033.12</b>	<b>0.00</b>

**PCO #PCO086R2**

Hausmann Construction, Inc.  
2106 Taylor Ave, Suite 400  
Norfolk, Nebraska 68701  
Phone: (402) 371-8650

Project: 21-068 - Woodbury County - Law Enforcement Center  
3701 28th St  
Sioux City, Iowa 51104

## Prime Contract Potential Change Order #PCO086R2: CE #PCO 086R2 - PR 36R - Elec

<b>TO:</b>	Woodbury County Law Enforcement 620 Douglas Street Sioux City, Iowa 51105	<b>FROM:</b>	Hausmann Construction, Inc. 8885 Executive Woods Drive Lincoln, Nebraska 68512
<b>PCO NUMBER/REVISION:</b>	PCO086R2 / 0	<b>CONTRACT:</b>	21-068 - Woodbury County - Law Enforcement Center
<b>REQUEST RECEIVED FROM:</b>		<b>CREATED BY:</b>	Klay Kasik (Hausmann Construction, Inc.)
<b>STATUS:</b>	Pending - In Review	<b>CREATED DATE:</b>	1/19/2024
<b>REFERENCE:</b>		<b>PRIME CONTRACT CHANGE ORDER:</b>	None
<b>FIELD CHANGE:</b>	No		
<b>LOCATION:</b>		<b>ACCOUNTING METHOD:</b>	Amount Based
<b>SCHEDULE IMPACT:</b>		<b>PAID IN FULL:</b>	No
<b>EXECUTED:</b>	No	<b>SIGNED CHANGE ORDER RECEIVED DATE:</b>	
		<b>TOTAL AMOUNT:</b>	\$28,916.00

**POTENTIAL CHANGE ORDER TITLE:** CE #PCO 086R2 - PR 36R - Elec

**CHANGE REASON:** Design Development

**POTENTIAL CHANGE ORDER DESCRIPTION:** *(The Contract Is Changed As Follows)*

CE #PCO 086R2 - PR 36R - Electrical Revisions For Vaccum Sealers & Walk-Ins

PCO 086R is created to incorporate the costs associated with PR 36 as itemized within. Please provide approval no later than February 2nd, 2024. Please note that all costs associated with the electrical changes on washer/dryer and mixers are submitted under PCO 084. Also please note that we are not waiving our right to include costs for General Conditions due to concurrent changes currently submitted. In the event that other change orders are not approved in their entirety (Pr35R & PR 38) this PCO will be subjected to additional general conditions.

This contemplates 00 added calendar days to the substantial completion.

Added durations for this project consist of:

- 18 added calendar days for Thompson
- 3 added calendar days for Kucera
- 2 added calendar days for Tri-State

**ATTACHMENTS:**

[21-068 -CO BACK UP 12.2223\[1\].pdf](#) , [\\_Woodbury Co PR 36R.pdf](#) , [\\_2024-01-18\\_090002.pdf klay.pdf](#) , [\\_PR-36R.pdf](#) , [\\_Woodbury Co PR 36R Updated Proposal.pdf](#)

#	Description	Amount
1	Thompson	\$20,925.00
2	Tri-State	\$745.00
3	Kucera	\$3,190.00
4	Hausmann	\$2,296.00
5	Fees	\$1,473.00
6	Bond & Insurance	\$287.00
<b>Grand Total:</b>		<b>\$28,916.00</b>



PCO #PCO086R2

**Kevin Rost (Goldberg Group Architects)**  
520 Francis Street Suite 200C  
St. Joseph, Missouri 64501

**Woodbury County Law Enforcement**  
620 Douglas Street  
Sioux City, Iowa 51105

**Hausmann Construction, Inc.**  
8885 Executive Woods Drive  
Lincoln, Nebraska 68512

DocuSigned by:

*Steve Thiele*

1/19/2024

380334A8122A46C...

\_\_\_\_\_  
SIGNATURE DATE

\_\_\_\_\_  
SIGNATURE DATE

\_\_\_\_\_  
SIGNATURE DATE





**Woodbury LEC**

**PR 36R - Electrical Revisions**

Cost Item: PR 36R - Electrical

21-068 DATE: 01/19/24

ITEM DESCRIPTION	QUANTITY	UNIT	MATERIAL COST		LABOR COSTS		EQUIPMENT COSTS		SUBCONTRACTOR		SUBTOTALS	
			Rate	TOTAL	RATE	TOTAL	Rate	TOTAL	Rate	TOTAL		
<b>Self Perform</b>												
Interim Cleaning	1	16.00	hours	\$ -	\$ -	\$ 60.00	\$ 960.00	\$ -	\$ -	\$ -	\$ -	\$ 960.00
Flooring Protection - Labor	1	8.00	hours	\$ -	\$ -	\$ 60.00	\$ 480.00	\$ -	\$ -	\$ -	\$ -	\$ 480.00
Flooring Protection - Material	1	1.00	roll	\$ 40.00	\$ 40.00	\$ -	\$ -	\$ -	\$ -	\$ -	\$ -	\$ 40.00
Travel & Perdiem	1	3.00	days	\$ -	\$ -	\$ 272.00	\$ 816.00	\$ -	\$ -	\$ -	\$ -	\$ 816.00
<b>Subcontracts</b>												
Thompson	1	1.00	lsum	\$ -	\$ -	\$ -	\$ -	\$ -	\$ -	\$ 20,925.00	\$ 20,925.00	\$ 20,925.00
Tri-State	1	1.00	lsum	\$ -	\$ -	\$ -	\$ -	\$ -	\$ -	\$ 745.00	\$ 745.00	\$ 745.00
Kucera	1	1.00	lsum	\$ -	\$ -	\$ -	\$ -	\$ -	\$ -	\$ 3,190.00	\$ 3,190.00	\$ 3,190.00
Subtotals				\$ 40.00	\$ 40.00	\$ 2,256.00	\$ 2,256.00	\$ -	\$ -	\$ 24,860.00	\$ 24,860.00	\$ 27,156.00
<b>Summary</b>												
Subtotal		\$	27,156.00									
Self-Perform Fee	10.0%	\$	230.00									
Sub Fee	5.0%	\$	1,243.00									
Bond & Insurance	1.0%	\$	287.00									
<b>Grand Total</b>		<b>\$</b>	<b>28,916.00</b>									



520 Francis Street, Suite 200C  
Saint Joseph, Missouri, 64501  
806-344-9879 | info@gga-pc.com  
[GoldbergArchitects.com](http://GoldbergArchitects.com)



## Work Changes Proposal Request

---

**PROJECT** *(Name and address):*

**Woodbury County Law Enforcement Center**  
3701 28<sup>th</sup> Street  
Sioux City, Iowa 51105

**PROPOSAL REQUEST NUMBER: 36R**

**DATE OF ISSUANCE: 01.09.2024**

**CONTRACT FOR: Woodbury County Law Enforcement Center**

**CONTRACT DATE: 06.28.2021**

**ARCHITECT'S PROJECT NUMBER: 16003-06**

OWNER

ARCHITECT

CONSULTANT

CONTRACTOR

FIELD

OTHER

**OWNER** *(Name and address):*

**Woodbury County Law Enforcement Authority**  
620 Douglas Street  
Sioux City, Iowa 51101

**FROM ARCHITECT** *(Name and address):*

**Goldberg Group Architects, PC**  
520 Francis Street, Suite 200C  
St. Joseph, Missouri 64501

**TO CONTRACTOR** *(Name and address):*

**Hausmann Construction, Inc.**  
2108 Taylor Avenue #850  
Norfolk, Nebraska 68701

---

Please submit an itemized proposal for changes in the Contract Sum and Contract Time for proposed modifications to the Contract Documents described herein. Within fourteen (14) days, the Contractor must submit this proposal or notify the Architect, in writing, of the date on which proposal submission is anticipated.

**THIS IS NOT A CHANGE ORDER, A CONSTRUCTION CHANGE DIRECTIVE OR A DIRECTION TO PROCEED WITH THE WORK DESCRIBED IN THE PROPOSED MODIFICATIONS.**

**DESCRIPTION** *(Insert a written description of the Work):*

Item No. 1 – Electrical Revisions:

Sheet EP1.02B – Lower Level Power Plan – South – Alternate Bid

- Relocate receptacle from Room 0041 to Room 0042 as requested by the Owner.
- Add Keyed Note 4 to plan.

REVISED FOR PR 36R - Sheet EP1.11 – Ground Floor Plan – North

- Add (3) additional receptacles for vacuum sealers in Room 1150 per Owner's request.
- Add Keyed Note 8 to verify plug configuration with manufacturer for 208V receptacles.

Sheet EP1.31 – Upper Roof Power Plan – North

- Revise cooler and freezer power for new units in lieu of existing ones.

REVISED FOR PR 36R - Sheet E7.04 – Electrical Panelboard Schedules

- Update schedules per electrical changes.

REVISED FOR PR 36R - Sheet E7.05 – Electrical Panelboard Schedules

- Update schedules per electrical changes.

**ATTACHMENTS** *(List attached documents that support description):*

Sheets EP1.02B, EP1.11, EP1.31, E7.04 & E7.05.

**REQUESTED BY THE ARCHITECT:**



*(Signature)*

**Carole Cline, Associate**

*(Printed name and title)*

### Proposal

KUCERA PAINTING INC  
1511 EAST 11TH STREET  
KEARNEY, NE 68847  
308-893-2075 or 402-461-1907  
kucerapainting@gmail.com

Proposal submitted to  
Address :

*Hausmann Corp*

*JOE Woodbury PR 36*

Proposal #

Proposal valid till date #

Number of pages

We hereby submit specifications and details for:

*Labor 2600.00 Material 1300.00 profit and overhead 2890.00  
TOTAL 6790.00*

We hereby propose to furnish material and labor to complete the job as per the above specifications for a sum of:

US\$ \_\_\_\_\_ (In figures) US\$ \_\_\_\_\_

With the terms of payments as follows: \_\_\_\_\_

Please revert for any clarification / further details.

Authorized Signatory: Name \_\_\_\_\_ Signature: *[Signature]*

### Acceptance of Proposal

I/We have reviewed your proposal and hereby indicate our acceptance of the same, as per the details, specifications and amounts mentioned in the proposal form. I/We agree to the proposed terms of payment and will release the funds as per agreed herein.

Authorized Signatory: Name \_\_\_\_\_ Signature: \_\_\_\_\_ Date \_\_\_\_\_



712-258-7653

# REQUEST FOR CHANGE ORDER

Ref.# CO-00004

External/RCO#

GC Ref#

Date Aug 22, 2023

Job # 37-21DI

**To: Hausmann Construction**  
 8545 Executive Woods Drive  
 Lincoln, NE 68512  
 Phone: 402-438-3230 Fax: 402-438-3235  
**Contact: Steve Thiele**

**Project: SC Law Enforcement**  
 3701 28th St  
 Sioux City, IA 51105  
**Contact: Klay Kasik**

Description: PR-36 Remove and replace grid &amp; Tile for HVAC work

Labor	Quantity UOM	Unit Total	Rate	Total
SUPERVISION	1.00 Hrs	1.00	63.02	\$63.02
DEMOLITION	3.00 Hrs	3.00	56.38	\$169.14
ACT GRID	4.00 Hrs	4.00	56.38	\$225.52
ACT TILE	1.00 Hrs	1.00	56.38	\$56.38
CLEAN-UP	3.00 Hrs	3.00	47.66	\$142.98
<b>Total Labor</b>				<b>\$657.04</b>
<b>Total Miscellaneous Charges</b>				<b>Total</b>
GAS				\$20.00
<b>Total Miscellaneous Charges</b>				<b>\$20.00</b>

**AUTHORIZED BY:**  
**ON BEHALF OF: Hausmann Construction**  
**PROJECT MANAGER: Jerome A. Reicks III**  
**ESTIMATOR: Jerry A. Reicks Jr**

<b>Labor Total:</b>	<b>\$657.04</b>
<b>Material Total:</b>	<b>\$0.00</b>
<b>Sub Trade Total:</b>	<b>\$0.00</b>
<b>Cleanup Total:</b>	<b>\$0.00</b>
<b>Equipment Total:</b>	<b>\$0.00</b>
<b>Misc. Total:</b>	<b>\$20.00</b>
<b>Sub Total:</b>	<b>\$677.04</b>
<b>Mark Up:</b>	<b>\$67.96 10.04%</b>

<b>Total:</b>	<b>\$745.00</b>
---------------	-----------------



# CHANGE ORDER PROPOSAL

## Updated Change Order Proposal # PR36R

**Submitted To:**

Date: 12/12/2023

Name: Hausmann Construction

Job Name: Woodbury LEC PR#36R

Street:

Street:

City:

City:

State:

Zip:

State:

Zip:

Change order proposal per updated PR36.

- Relocate outlet from Rm 0041 to 0042
- Add (3) additional outlets for vacuum sealers in 1150. Route to SA-1LPK1
- Revise cooler & freezer power.

**Clarifications:**

- Removal and replacing ceiling if needed by others.
- Breakers have an estimated lead time of 1 week.

Labor \$15,435.00 (2) guys 2 weeks.

Material \$5,490.00

**Total Price: \$20,925.00**

By: 

*Price Valid for 15 days*

*Payment to made as follows: Net 30 days*

### ACCEPTANCE OF CHANGE ORDER

The above prices, specifications, terms, and conditions are satisfactory and agreed to, and are hereby accepted. Thompson Solutions Group is hereby authorized to do the work as specified. Payment will be made as outlined above.

Accepted By:

Date:

*Signature*

**Sioux City**  
2300 7th Street • Sioux City, IA 51105  
Ph: 712.252.4221

**Omaha**  
3505 S. 61st Ave Cir • Omaha, NE 68106  
Ph: 402.891.9480

**Sioux Falls**  
1028 South Lyons Ave • Sioux Falls, SD 57106  
Mailing: P.O. Box 88338 • Sioux Falls, SD 57109-8338  
Ph: 605.331.4588

**Certificate Of Completion**

Envelope Id: C5BBB3FEF55F4A1A927D8DDF2A7807A6	Status: Sent
Subject: 21-068 Woodbury - PCO 086R2 - PR 36R - Elec - FOR APPROVAL	
Source Envelope:	
Document Pages: 13	Signatures: 1
Certificate Pages: 5	Initials: 1
AutoNav: Enabled	Envelope Originator:
Envelope Stamping: Enabled	Amy Ahlers
Time Zone: (UTC-06:00) Central Time (US & Canada)	8885 Executive Woods Drive
	Lincoln, NE 68512
	amya@hausmannconstruction.com
	IP Address: 34.225.141.179

**Record Tracking**

Status: Original	Holder: Amy Ahlers	Location: DocuSign
1/19/2024 1:32:14 PM	amya@hausmannconstruction.com	

**Signer Events**

Signer Events	Signature	Timestamp
Klay Kasik klayk@hausmannconstruction.com Sr. Project Manager Hausmann Construction Security Level: Email, Account Authentication (None)	 Signature Adoption: Pre-selected Style Using IP Address: 209.50.13.227	Sent: 1/19/2024 2:10:48 PM Viewed: 1/19/2024 2:11:12 PM Signed: 1/19/2024 2:11:20 PM

**Electronic Record and Signature Disclosure:**  
Not Offered via DocuSign

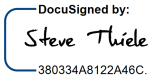
Steve Thiele stevet@hausmannconstruction.com Vice President Hausmann Construction, Inc. Security Level: Email, Account Authentication (None)	 Signature Adoption: Pre-selected Style Using IP Address: 70.37.212.90 Signed using mobile	Sent: 1/19/2024 2:11:22 PM Viewed: 1/19/2024 9:17:14 PM Signed: 1/19/2024 9:17:44 PM
--	---	--

**Electronic Record and Signature Disclosure:**  
Not Offered via DocuSign

Kevin Rost kevin.r@gga.llc Security Level: Email, Account Authentication (None)		Sent: 1/19/2024 9:17:47 PM Viewed: 1/20/2024 3:15:18 PM
---	--	--

**Electronic Record and Signature Disclosure:**  
Accepted: 5/30/2023 11:10:56 AM  
ID: 5b5978e2-1b2f-49e4-8628-3218a723a521

Ron Wieck  
rwieck65@gmail.com  
Security Level: Email, Account Authentication (None)

**Electronic Record and Signature Disclosure:**  
Accepted: 12/6/2022 6:20:49 PM  
ID: cb840872-8216-42eb-9ac6-0ad45abc3082

In Person Signer Events	Signature	Timestamp
Editor Delivery Events	Status	Timestamp
Agent Delivery Events	Status	Timestamp
Intermediary Delivery Events	Status	Timestamp

Certified Delivery Events	Status	Timestamp
<b>Carbon Copy Events</b> Shane Albrecht albrechts@thebakergroup.com Security Level: Email, Account Authentication (None) <b>Electronic Record and Signature Disclosure:</b> Not Offered via DocuSign	<div style="border: 2px solid blue; padding: 5px; display: inline-block; color: blue; font-weight: bold; font-size: 1.2em;">COPIED</div>	Sent: 1/19/2024 9:17:48 PM
Todd Wieck wieckt@TheBakerGroup.com Security Level: Email, Account Authentication (None) <b>Electronic Record and Signature Disclosure:</b> Not Offered via DocuSign	<div style="border: 2px solid blue; padding: 5px; display: inline-block; color: blue; font-weight: bold; font-size: 1.2em;">COPIED</div>	Sent: 1/19/2024 9:17:48 PM Viewed: 1/24/2024 9:20:34 PM
Shane Albrecht albrechts@thebakergroup.com Security Level: Email, Account Authentication (None) <b>Electronic Record and Signature Disclosure:</b> Not Offered via DocuSign		
Todd Wieck wieckt@TheBakerGroup.com Security Level: Email, Account Authentication (None) <b>Electronic Record and Signature Disclosure:</b> Not Offered via DocuSign		
Witness Events	Signature	Timestamp
Notary Events	Signature	Timestamp
Envelope Summary Events	Status	Timestamps
Envelope Sent	Hashed/Encrypted	1/19/2024 2:10:48 PM
Payment Events	Status	Timestamps
Electronic Record and Signature Disclosure		

## **ELECTRONIC RECORD AND SIGNATURE DISCLOSURE**

From time to time, Hausmann Construction, Inc. (we, us or Company) may be required by law to provide to you certain written notices or disclosures. Described below are the terms and conditions for providing to you such notices and disclosures electronically through the DocuSign system. Please read the information below carefully and thoroughly, and if you can access this information electronically to your satisfaction and agree to this Electronic Record and Signature Disclosure (ERSD), please confirm your agreement by selecting the check-box next to 'I agree to use electronic records and signatures' before clicking 'CONTINUE' within the DocuSign system.

### **Getting paper copies**

At any time, you may request from us a paper copy of any record provided or made available electronically to you by us. You will have the ability to download and print documents we send to you through the DocuSign system during and immediately after the signing session and, if you elect to create a DocuSign account, you may access the documents for a limited period of time (usually 30 days) after such documents are first sent to you. After such time, if you wish for us to send you paper copies of any such documents from our office to you, you will be charged a \$0.00 per-page fee. You may request delivery of such paper copies from us by following the procedure described below.

### **Withdrawing your consent**

If you decide to receive notices and disclosures from us electronically, you may at any time change your mind and tell us that thereafter you want to receive required notices and disclosures only in paper format. How you must inform us of your decision to receive future notices and disclosure in paper format and withdraw your consent to receive notices and disclosures electronically is described below.

### **Consequences of changing your mind**

If you elect to receive required notices and disclosures only in paper format, it will slow the speed at which we can complete certain steps in transactions with you and delivering services to you because we will need first to send the required notices or disclosures to you in paper format, and then wait until we receive back from you your acknowledgment of your receipt of such paper notices or disclosures. Further, you will no longer be able to use the DocuSign system to receive required notices and consents electronically from us or to sign electronically documents from us.

### **All notices and disclosures will be sent to you electronically**



Unless you tell us otherwise in accordance with the procedures described herein, we will provide electronically to you through the DocuSign system all required notices, disclosures, authorizations, acknowledgements, and other documents that are required to be provided or made available to you during the course of our relationship with you. To reduce the chance of you inadvertently not receiving any notice or disclosure, we prefer to provide all of the required notices and disclosures to you by the same method and to the same address that you have given us. Thus, you can receive all the disclosures and notices electronically or in paper format through the paper mail delivery system. If you do not agree with this process, please let us know as described below. Please also see the paragraph immediately above that describes the consequences of your electing not to receive delivery of the notices and disclosures electronically from us.

**How to contact Hausmann Construction, Inc.:**

You may contact us to let us know of your changes as to how we may contact you electronically, to request paper copies of certain information from us, and to withdraw your prior consent to receive notices and disclosures electronically as follows:

To contact us by email send messages to: [nateg@hausmannconstruction.com](mailto:nateg@hausmannconstruction.com)

**To advise Hausmann Construction, Inc. of your new email address**

To let us know of a change in your email address where we should send notices and disclosures electronically to you, you must send an email message to us at [nateg@hausmannconstruction.com](mailto:nateg@hausmannconstruction.com) and in the body of such request you must state: your previous email address, your new email address. We do not require any other information from you to change your email address.

If you created a DocuSign account, you may update it with your new email address through your account preferences.

**To request paper copies from Hausmann Construction, Inc.**

To request delivery from us of paper copies of the notices and disclosures previously provided by us to you electronically, you must send us an email to [nateg@hausmannconstruction.com](mailto:nateg@hausmannconstruction.com) and in the body of such request you must state your email address, full name, mailing address, and telephone number. We will bill you for any fees at that time, if any.

**To withdraw your consent with Hausmann Construction, Inc.**

To inform us that you no longer wish to receive future notices and disclosures in electronic format you may:

i. decline to sign a document from within your signing session, and on the subsequent page, select the check-box indicating you wish to withdraw your consent, or you may;

ii. send us an email to [nateg@hausmannconstruction.com](mailto:nateg@hausmannconstruction.com) and in the body of such request you must state your email, full name, mailing address, and telephone number. We do not need any other information from you to withdraw consent.. The consequences of your withdrawing consent for online documents will be that transactions may take a longer time to process..

### **Required hardware and software**

The minimum system requirements for using the DocuSign system may change over time. The current system requirements are found here: <https://support.docusign.com/guides/signer-guide-signing-system-requirements>.

### **Acknowledging your access and consent to receive and sign documents electronically**

To confirm to us that you can access this information electronically, which will be similar to other electronic notices and disclosures that we will provide to you, please confirm that you have read this ERSD, and (i) that you are able to print on paper or electronically save this ERSD for your future reference and access; or (ii) that you are able to email this ERSD to an email address where you will be able to print on paper or save it for your future reference and access. Further, if you consent to receiving notices and disclosures exclusively in electronic format as described herein, then select the check-box next to ‘I agree to use electronic records and signatures’ before clicking ‘CONTINUE’ within the DocuSign system.

By selecting the check-box next to ‘I agree to use electronic records and signatures’, you confirm that:

- You can access and read this Electronic Record and Signature Disclosure; and
- You can print on paper this Electronic Record and Signature Disclosure, or save or send this Electronic Record and Disclosure to a location where you can print it, for future reference and access; and
- Until or unless you notify Hausmann Construction, Inc. as described above, you consent to receive exclusively through electronic means all notices, disclosures, authorizations, acknowledgements, and other documents that are required to be provided or made available to you by Hausmann Construction, Inc. during the course of your relationship with Hausmann Construction, Inc..

**PCO #109R3**

Hausmann Construction, Inc.  
2106 Taylor Ave, Suite 400  
Norfolk, Nebraska 68701  
Phone: (402) 371-8650

Project: 21-068 - Woodbury County - Law Enforcement Center  
3701 28th St  
Sioux City, Iowa 51104

## Prime Contract Potential Change Order #109R3: CE #PCO 109 R3 - RFI #519 - Fire ceilings

<b>TO:</b>	Woodbury County Law Enforcement 620 Douglas Street Sioux City, Iowa 51105	<b>FROM:</b>	Hausmann Construction, Inc. 8885 Executive Woods Drive Lincoln, Nebraska 68512
<b>PCO NUMBER/REVISION:</b>	109R3 / 0	<b>CONTRACT:</b>	21-068 - Woodbury County - Law Enforcement Center
<b>REQUEST RECEIVED FROM:</b>		<b>CREATED BY:</b>	Klay Kasik (Hausmann Construction, Inc.)
<b>STATUS:</b>	Pending - In Review	<b>CREATED DATE:</b>	1/19/2024
<b>REFERENCE:</b>		<b>PRIME CONTRACT CHANGE ORDER:</b>	#023 - PCCO 023
<b>FIELD CHANGE:</b>	No		
<b>LOCATION:</b>		<b>ACCOUNTING METHOD:</b>	Amount Based
<b>SCHEDULE IMPACT:</b>		<b>PAID IN FULL:</b>	No
<b>EXECUTED:</b>	No	<b>SIGNED CHANGE ORDER RECEIVED DATE:</b>	
		<b>TOTAL AMOUNT:</b>	(\$1,578.00)

**POTENTIAL CHANGE ORDER TITLE:** CE #PCO 109 R3 - RFI #519 - Fire ceilings

**CHANGE REASON:** Design Development

**POTENTIAL CHANGE ORDER DESCRIPTION:** *(The Contract Is Changed As Follows)*

**RFI #519 - Fire Rated Ceilings Area A**

PCO 109 is created to incorporate the costs associated with RFI #519 as itemized within. Please provide approval no later than February 2, 2024. Please note the lead time for access panels is between 4 to 6 weeks out upon approval. Also please note that we are not waiving our right to include costs for General Conditions due to concurrent changes that are concurrently being priced. In the event that other change orders are not approved this PCO will be subjected to additional general conditions.

This contemplates 00 added calendar days to the substantial completion.

Added durations for this project consist of:

- 21 added calendar days for Ramirez
- 1 added calendar day for Suter
- 2 added calendar days for Thompson
- 2 added calendar days for Williams
- 3 added calendar days for Kucera

**ATTACHMENTS:**

[21-068 -CO BACK UP 12.2223\[1\].pdf](#) , [\\_A7.11\\_ GROUND FLOOR REFLECTED CEILING PLAN Rev.3 markup \(5\).pdf](#) , [\\_Kucera - RFI 519.pdf](#) , [\\_Williams Restoration - RFI #519.pdf](#) , [\\_Thompson - RFI #519.pdf](#) , [\\_Suter - RFI #519.pdf](#) , [\\_Tri-State -RFI #519.pdf](#) , [\\_RAMIREZ - RFI #519.pdf](#) , [\\_RFI 519R - Fire Rated Acoustical Celings - Area A \(Response\).pdf](#)

#	Description	Amount
1	Ramirez	\$15,320.00
2	Pauly Jail	\$848.00
3	Tri-State	\$2,345.00
4	Suter	\$539.00
5	Thompson	\$1,460.00
6	WRC	\$2,600.00



PCO #109R3

#	Description	Amount
7	Kucera	\$1,650.00
8	Framing Material	\$2,000.00
9	Masonry	\$(13,011.00)
10	Rebar	\$(4,325.00)
11		\$(10,973.00)
12	Fees	\$(31.00)
<b>Grand Total:</b>		<b>\$(1,578.00)</b>

**Kevin Rost (Goldberg Group Architects)**  
 520 Francis Street Suite 200C  
 St. Joseph, Missouri 64501

**Woodbury County Law Enforcement**  
 620 Douglas Street  
 Sioux City, Iowa 51105

**Hausmann Construction, Inc.**  
 8885 Executive Woods Drive  
 Lincoln, Nebraska 68512

DocuSigned by:

*Steve Thiele*

2/8/2024

380334A8122A46C...

\_\_\_\_\_  
SIGNATURE DATE

\_\_\_\_\_  
SIGNATURE DATE

\_\_\_\_\_  
SIGNATURE DATE





**Woodbury LEC**  
RFI #519 - Fire Rated Ceilings  
Area A

RFI #519 - Fire Rated Ceilings  
21-068 DATE: 01/19/24

ITEM DESCRIPTION	QUANTITY	UNIT	MATERIAL COST		LABOR COSTS		EQUIPMENT COSTS		SUBCONTRACTOR		SUBTOTALS
			Rate	TOTAL	RATE	TOTAL	Rate	TOTAL	Rate	TOTAL	
<b>Self Perform</b>											\$ 2,000.00
Framing Material	1	1.00	Isum	\$ 2,000.00	\$ 2,000.00	\$ -	\$ -	\$ -	\$ -	\$ -	\$ 2,000.00
<b>Subcontracts</b>											\$ (3,546.53)
Ramirez	1	1.00	Isum	\$ -	\$ -	\$ -	\$ -	\$ -	\$ 15,320.00	\$ 15,320.00	\$ 15,320.00
Pauly Jail	1	1.00	Isum	\$ -	\$ -	\$ -	\$ -	\$ -	\$ 848.00	\$ 848.00	\$ 848.00
Tri-State	1	1.00	Isum	\$ -	\$ -	\$ -	\$ -	\$ -	\$ 2,345.00	\$ 2,345.00	\$ 2,345.00
Suter (Furnish Fire Blankets -Diffuser In Lieu Of Fire Caulking)	1	1.00	Isum	\$ -	\$ -	\$ -	\$ -	\$ -	\$ 539.00	\$ 539.00	\$ 539.00
Thompson	1	1.00	Isum	\$ -	\$ -	\$ -	\$ -	\$ -	\$ 1,460.00	\$ 1,460.00	\$ 1,460.00
Williams	1	1.00	Isum	\$ -	\$ -	\$ -	\$ -	\$ -	\$ 2,600.00	\$ 2,600.00	\$ 2,600.00
Kucera	1	1.00	Isum	\$ -	\$ -	\$ -	\$ -	\$ -	\$ 1,650.00	\$ 1,650.00	\$ 1,650.00
Blackhawk (Credit Was Given Within PCO 103)	1	1.00	Isum	\$ -	\$ -	\$ -	\$ -	\$ -	\$ -	\$ -	\$ -
Prairie Fire (Credit)	1	1.00	Isum	\$ -	\$ -	\$ -	\$ -	\$ -	\$ -	\$ -	\$ -
Blackhawk credit from PR 35R(will be billed to offset costs in PR 35R)	1	1.00	Isum	\$ -	\$ -	\$ -	\$ -	\$ -	\$ (13,011.00)	\$ (13,011.00)	\$ (13,011.00)
Nucor(will be billed to offset costs in PR 35R)	1	1.00	Isum	\$ -	\$ -	\$ -	\$ -	\$ -	\$ (4,325.00)	\$ (4,325.00)	\$ (4,325.00)
CCS (will be billed to offset costs in PR 35R)	1	1.00	Isum	\$ -	\$ -	\$ -	\$ -	\$ -	\$ (10,972.53)	\$ (10,972.53)	\$ (10,972.53)
Apache- billed through PR 35R	1	1.00	Isum	\$ -	\$ -	\$ -	\$ -	\$ -	\$ -	\$ -	\$ -
Williams- credit included in wall type Contractor	1	1.00	Isum	\$ -	\$ -	\$ -	\$ -	\$ -	\$ -	\$ -	\$ -
Subtotals				\$ 2,000.00	\$ -	\$ -	\$ -	\$ -	\$ (3,546.53)	\$ (1,546.53)	
<b>Subtotal</b>					\$ (1,547.00)						
<b>Self-Perform Fee</b>											
<b>Sub Fee</b>	2.0%				\$ (31.00)						
<b>Bond &amp; Insurance</b>	0.0%				\$ -						
<b>Grand Total</b>					\$ (1,578.00)						

**From:** Rick Kucera <kucerapainting@gmail.com>

**Sent:** Monday, November 27, 2023 2:03 PM

**To:** Nathan Thege <NathanT@hausmannconstruction.com>

**Subject:** Re: Woodbury County LEC - Kucera - RFI #519 – Fire Rated Ceilings Area A

labor \$1000.00 material \$500.00 profit and overhead \$150.00 total \$1650.00

# WILLIAMS RESTORATION COMPANY

725 N. Frontier Road  
Papillion, NE 68046  
www.williamsrestorationcompany.com

Phone No.: (402) 597-1200  
Chris@foxwrc.com

Attn: **Estimating Department**

**November 2, 2023**

Re: **Woodbury Fire Spray**

**Scope of Work:** Please accept this proposal for the installation of **Fire Spray**. All work to be performed according to the project drawings, also referred to the project specifications.

**Fire Spray**

1. Stuff and spray the top of 2 added firewalls as shown on the highlighted drawing provided by Ben Cochran (Hausmann) to Ed Midgette (WRC) on November 2, 2023.

**Bid Price: \$2,600**

**Specific Exclusions:**

1. Acoustical Sealants
2. Hot Pour Sealants
3. Sealants at Flashing
4. Custom or non-standard colors for ANY products
5. Excavating
6. Backfilling
7. Core Drilling
8. Drain Tile
9. Penetration Firestopping and Joint Sealants
10. Preformed compressed joints

Bond Not Included  
Bond Rate 3%  
*Acknowledge Addenda*

Price includes all material, labor, equipment, travel, and insurance to complete the work described above only. Progress payment will be monthly for work complete with final payment due upon completion. If you have any questions or need any additional information, please contact this office.

Authorized Signature: **Chris Dietze**

Note: This proposal may be withdrawn by us if not accepted in 30 days.

Acceptance of Proposal: The prices, specifications, and conditions outlined above are satisfactory and are hereby accepted. You are authorized to do the work as specified with the payments to be made as stated above.

Date of Acceptance: \_\_\_\_\_ Signature: \_\_\_\_\_

## Nathan Thege

---

**From:** Shannon Vornhagen <Shannon.Vornhagen@thompsonsolutionsgroup.com>  
**Sent:** Tuesday, October 3, 2023 11:39 AM  
**To:** Nathan Thege  
**Subject:** Fire Rated light covers  
**Attachments:** FF130-2x2-Specification.pdf; FF130-Installation.pdf

Nathan,  
Here is what we found for fire rated covers for 2x2 light fixtures.

Price for them is \$72.80 each plus shipping and handling and 1 hour of labor at \$78.50 for a total of \$151.30 each plus shipping and handling.

Fire Rated Light Covers - QTY 12  
- Material - \$873.60  
- Labor - \$942  
- Shipping & Handling - \$250

Sincerely,

Total = \$2065.60



**SHANNON VORNHAGEN**  
*Project Manager - Electrical Construction*  
O:712.224.3894  
C:712.389.5257  
[ThompsonSolutionsGroup.com](http://ThompsonSolutionsGroup.com)  
**BUILDING BETTER TOGETHER**

**DID YOU  
KNOW ?**

Thompson Solutions Group's engineering department offers complete mechanical, electrical, & plumbing design services utilizing the industry's latest technology including BIM and 3D modeling.





## Nathan Thege

---

**From:** Austin Huisman <ahuisman@cwsuter.com>  
**Sent:** Friday, September 22, 2023 10:10 AM  
**To:** David Tobar  
**Cc:** Austin Huisman  
**Subject:** Woodbury LEC - Fire Blanket/Fire Diffuser Options  
**Attachments:** (Fire Rated-Blanket) 2023-09-22 Mineral Wool Blanket.pdf; (Fire Rated Diffuser) 1400FR\_EngineeringSpecification.pdf; (Fire Rated Diffuser) 1400FR Submittal.pdf; M1.11-GROUND-FLOOR-MECHANICAL-DUCTWORK-FLOOR-PLAN-Rev.6.pdf

**Follow Up Flag:** Follow up  
**Flag Status:** Flagged

Dave,

Following up on our conversation on the phone this morning regarding the different options to make the ceiling supply diffusers in the corridor fire-rated

The attachments included the specifications of both the fire-rated diffuser blanket and the fire-rated diffusers.

Please see below for the cost of both options to PROVIDE/INSTALL to make the supply diffusers fire-rated per the drawing M1.11 attached, shown clouded in Red.

- Total Cost = ~~\$389.00~~ - (Qty 7) (Fire Rated-Blanket) 222.29 - Qty. 4
- Total Cost = ~~\$1,496.00~~ - (Qty 7) (Fire Rated-Diffuser) 854.86 - Qty. 4

Don't hesitate to contact me if you have any questions or concerns.

Thank you,

**Austin Huisman**  
Estimator/Project Manager



CW Suter | 1800 11<sup>th</sup> St | Sioux City, Iowa 51101  
Cell 712-635-2913 | DL 712-224-2413 | Fax 712-252-2410  
[www.cwsuter.com](http://www.cwsuter.com)



712-258-7653

# REQUEST FOR CHANGE ORDER

Ref.# CO-00008  
 External/RCO#  
 GC Ref#  
 Date Sep 19, 2023  
 Job # 37-21DI

**To: Hausmann Construction**  
 8545 Executive Woods Drive  
 Lincoln, NE 68512  
 Phone: 402-438-3230 Fax: 402-438-3235  
**Contact: Steve Thiele**

**Project: SC Law Enforcement**  
 3701 28th St  
 Sioux City, IA 51105  
**Contact: Klay Kasik**

Description: Change SHM-197 to either PBT-197 or PFF-197

Total Miscellaneous Charges	Total
Change SHM-197 to either PBT197 or PFF-197	\$1,745.00
Freight LTL	\$325.00
<b>Total Miscellaneous Charges</b>	<b>\$2,070.00</b>

**AUTHORIZED BY: Nathan Thege**  
**ON BEHALF OF: Hausmann Construction**  
**PROJECT MANAGER: Jerome A. Reicks III**  
**ESTIMATOR: Jerry A. Reicks Jr**

Labor Total:	\$0.00
Material Total:	\$0.00
Sub Trade Total:	\$0.00
Cleanup Total:	\$0.00
Equipment Total:	\$0.00
Misc. Total:	\$2,070.00
Sub Total:	\$2,070.00
Mark Up:	\$206.70 9.99%

<b>Total:</b>	<b>\$2,345.00</b>
---------------	-------------------

Mineral Fiber Ceilings

## Baroque™

Mineral Fiber Ceilings

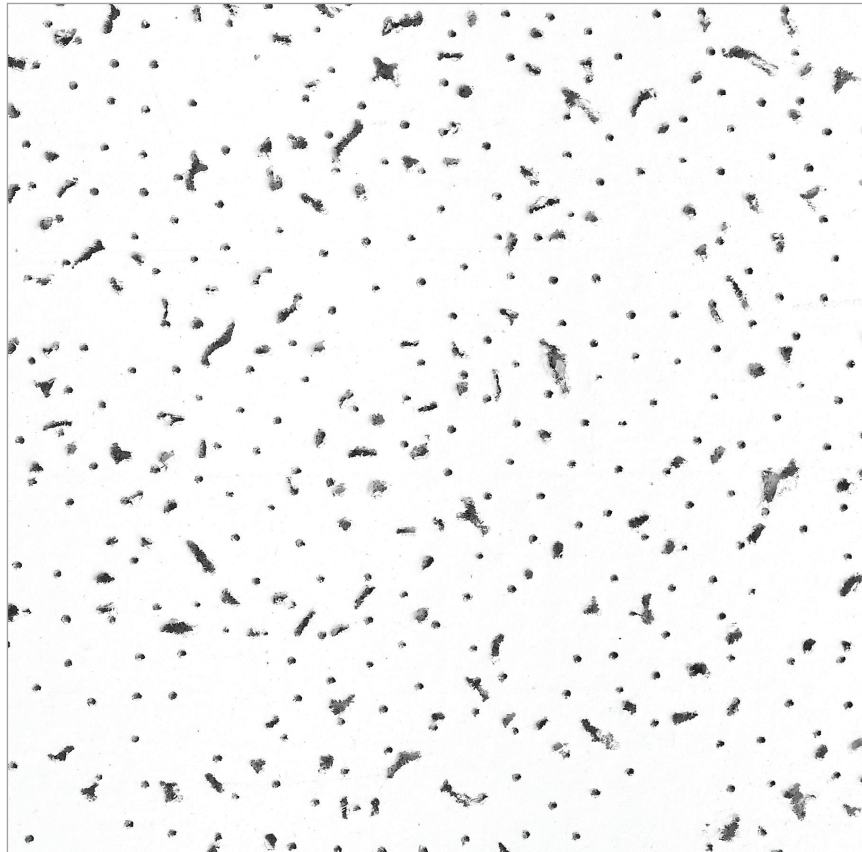

LOW VOC

\$\$\$\$



### LEED® v4

- MR: Environmental Product Declarations (EPDs)
- MR: Sourcing Raw Materials
- MR: Material Ingredients (HPDs)
- IEQ: Daylight
- IEQ: Low-Emitting Materials
- IEQ: Prereq. Min. Acoustic Performance (Schools)
- IEQ: Acoustic Performance
- MR: PBT Source Reduction (Healthcare)
- IEQ: Interior Lighting
- EA: Prereq. Min. Energy Performance
- EA: Optimize Energy Performance

**Recycled Content**

<input checked="" type="radio"/> CLASS A	Pre: <b>28%</b>	Post: <b>2%</b>
PROTECTONE®	Pre: <b>37%</b>	Post: <b>1%</b>

### TOOLS

Visit [CertainTeed.com/Ceilings](http://CertainTeed.com/Ceilings)  
Download HPDs and EPDs  
LEED® Information / BIM Objects  
3-Part Specs / Data Pages



Carbon Footprint Reduction  
Rapidly Renewable Resource Content  
Recycled Content



EPD Available



HPD Available

### FEATURES & BENEFITS

- 100% non-directional fissured pattern
- Higher sound absorption than comparable products
- Third-party verified Environmental Product Declaration (EPD) available for this product
- Available in fire-rated (Protectone®) version
- Health Product Declaration (HPD) available for this product

### APPLICATIONS

- Utility Areas
- Retail Warehouses
- Strip Malls
- Commercial Interior Spaces
- Offices
- Other Commercial Buildings / Space Applications

### AVAILABLE EDGE DETAILS



Trim  
15/16 Grid



Reveal  
Beveled  
15/16 Grid



Narrow Reveal  
Corner Bevel  
9/16 Grid



Narrow Reveal  
Corner Bevel  
9/16 Grid Bolt Slot



Baroque™ Reveal (BET-154)

**ATTRIBUTES**

	DIMENSIONS INCHES	EDGE DETAIL	UL CLASSIFIED NRC	CAC	EPD AVAILABLE	HPD AVAILABLE	SAG RESISTANT	MOLD RESISTANT	LR	WASHABLE	FIRE CLASS ASTM E1264	EMISSION COMPLIANT	RECYCLED CONTENT
<b>BAROQUE™</b>													
<b>BET-157</b>	24 x 24 x 5/8	Trim	0.60	33	Yes	Yes	—	—	0.83	—	Class A	Certified	30%
<b>PBT-157</b>	24 x 24 x 5/8	Trim	0.55	35	Yes	Yes	—	—	0.83	—	Protectone*	Certified	38%
<b>BET-154</b>	24 x 24 x 5/8	Reveal	0.60	33	Yes	Yes	—	—	0.83	—	Class A	Certified	30%
<b>PBT-154</b>	24 x 24 x 5/8	Reveal	0.55	35	Yes	Yes	—	—	0.83	—	Protectone*	Certified	38%
<b>BET-150</b>	24 x 24 x 5/8	Narrow Reveal	0.60	33	Yes	Yes	—	—	0.83	—	Class A	Certified	30%
<b>BET-197</b>	24 x 48 x 5/8	Trim	0.60	35	Yes	Yes	—	—	0.83	—	Class A	Certified	30%
<b>PBT-197</b>	24 x 48 x 5/8	Trim	0.55	40	Yes	Yes	—	—	0.83	—	Protectone*	Certified	38%
<b>BET-194</b>	24 x 48 x 5/8	Reveal	0.60	35	Yes	Yes	—	—	0.83	—	Class A	Certified	30%
<b>BET-2067</b>	20 x 60 x 5/8	Trim	0.60	35	Yes	Yes	—	—	0.83	—	Class A	Certified	30%

**BAROQUE™ - METRIC**

<b>BET-2067M</b>	(500 x 1500 x 15)	Trim	0.60	35	Yes	Yes	—	—	0.83	—	Class A	Certified	30%
------------------	-------------------	------	------	----	-----	-----	---	---	------	---	---------	-----------	-----

\*Protectone\*: A fire-resistive ceiling when used in applicable UL assemblies.

**CAN'T FIND A SIZE?** Contact your local Sales Representative or call 800-233-8990

**PHYSICAL DATA**

**MATERIAL**

Mineral Fiber

**ASTM E1264 CLASSIFICATION**

Type III, Form 2, Pattern C D

**FIRE CLASS (ASTM E1264)**

Tested according to ASTM E84 & CAN S102

Flame Spread: 25 or less

Smoke Developed: 50 or less

**VOC EMISSIONS**

Independently certified compliant with California Department of Public Health CDPH/EHLB/Standard Method Version 1.1, 2010.

**MAINTENANCE**

Wipe with a soft cloth or vacuum with brush attachment.

**WARRANTY**

1-year Limited Warranty

Technical Support | [certainteed.com/ceilings](http://certainteed.com/ceilings) 800-233-8990

© 05/18 CertainTeed Corporation



Fissured  
Mineral Fiber

A non-directional mineral fiber panel for all-around workability, affordability and great-looking installations.



**APPLICATIONS**

- Schools / Classrooms
- Libraries / Media Centers
- Retail / Department Stores
- Offices
- Open Plan Areas
- Healthcare Spaces – High NRC
- Computer Rooms – High NRC
- Other Commercial Buildings / Space Applications

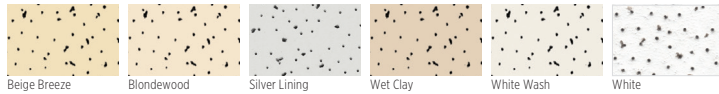

**FEATURES AND BENEFITS**

- Non-directional fissured pattern
- Cuts cleanly, leading to quicker installation and lower installation costs
- High NRC panels are excellent for budgeted projects requiring high sound absorption
- High NRC panels comply with LEED v4 for School classroom acoustics prerequisite
- Customline options provide three dramatic geometric designs with discreet small-scale fissure pattern
- Deep face-scoring assists in masking the presence of metal grid on Customline products
- High humidity and sag resistant
- Some products available in fire-rated (Protectone) versions
- Environmental Product Declaration (EPD) available for this product
- Health Product Declaration (HPD) available for this product
- Available in 6 standard colors for item numbers HHF-154, HHF-157, HHF-197, FFCL-224
- High NRC has USDA Certified Biobased content of 98%

**SUSPENSION SYSTEM OPTIONS**

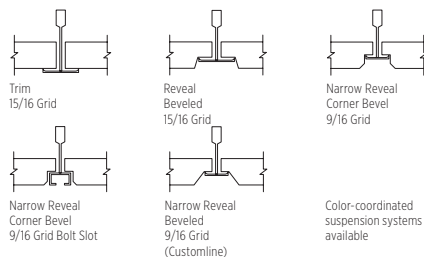

**CUSTOMLINE SCORING OPTIONS**

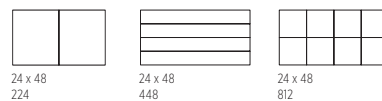

**LEED® v4**

**RECYCLED CONTENT**

<b>CLASS A</b>	<b>33 - 70%</b>
<b>PROTECTONE®</b>	<b>44%</b>

- EA: Optimize Energy Performance
- EA: Prereq. Min. Energy Performance
- EQ: Interior Lighting
- MR: PBT Source Reduction (Healthcare)
- EQ: Acoustic Performance
- EQ: Prereq. Min. Acoustic Performance (Schools) *Applies only to High NRC*
- EQ: Low-Emitting Materials
- EQ: Daylight
- MR: Material Ingredients (HPDs)
- MR: Sourcing Raw Materials
- MR: Environmental Product Declarations (EPDs)
- MR: Construction and Demolition Waste Management Planning

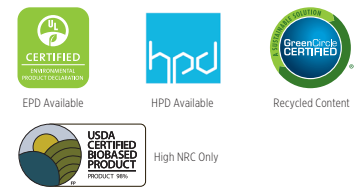

Customer Support | [certainteed.com/ceilings](http://certainteed.com/ceilings) | 800-233-8990

**FINE FISSURED | FINE FISSURED HIGH NRC | FINE FISSURED CUSTOMLINE®**

Fissured  
Mineral Fiber

All products in this line feature these attributes:

SAG RESISTANT
 BIOSHIELD® MOLD/MILDEW RESISTANT
 LR 0.83/0.84
 EPD AVAILABLE
 HPD AVAILABLE
 LOW VOC EMISSION COMPLIANT CERTIFIED
 RECYCLED CONTENT 33-70%

**FINE FISSURED HIGH NRC**

	Format	Dimensions (in.)	NRC (UL Classified)	CAC (UL Classified)	Recycled Content	UL Fire-Rated	LR	Pieces/carton	Sq. Ft./carton	Lbs./carton	Cartons/pallet		
<b>TRIM</b>													
	NRC 70	HHF-457 HNRC	Panels	24 x 24 x 3/4	0.70	35	70%	—	0.83	14	56	55	16
		HHF-497 HNRC	Panels	24 x 48 x 3/4	0.70	35	70%	—	0.83	8	64	62	16
<b>REVEAL</b>													
	NRC 70	HHF-454 HNRC	Panels	24 x 24 x 3/4	0.70	35	70%	—	0.83	14	56	55	16
		HHF-494 HNRC	Panels	24 x 48 x 3/4	0.70	35	70%	—	0.83	8	64	62	16

**FINE FISSURED**

	Format	Dimensions (in.)	NRC (UL Classified)	CAC (UL Classified)	Recycled Content	UL Fire-Rated	LR	Pieces/carton	Sq. Ft./carton	Lbs./carton	Cartons/pallet		
<b>TRIM</b>													
	NRC 55	HHF-157	Panels	24 x 24 x 5/8	0.55	33	33%	—	0.84	16	64	50	20
		PFF-157	Panels	24 x 24 x 5/8	0.55	35	44%	Yes*	0.84	16	64	70	20
		HHF-197	Panels	24 x 48 x 5/8	0.55	35	33%	—	0.84	8	64	45	20
		PFF-197	Panels	24 x 48 x 5/8	0.55	40	44%	Yes*	0.84	8	64	70	20
		HHF-177	Panels	20 x 48 x 5/8	0.55	35	33%	—	0.84	8	80	51	20
		HHF-2067	Panels	20 x 60 x 5/8	0.55	35	33%	—	0.84	8	66.7	52	16
<b>REVEAL</b>													
	NRC 55	HHF-154	Panels	24 x 24 x 5/8	0.55	33	33%	—	0.84	16	64	45	20
		PFF-154	Panels	24 x 24 x 5/8	0.55	35	44%	Yes*	0.84	16	64	70	20
		HHF-194	Panels	24 x 48 x 5/8	0.55	35	33%	—	0.84	8	64	45	20
<b>NARROW REVEAL</b>													
	NRC 55	HHF-150	Panels	24 x 24 x 5/8	0.55	35	33%	—	0.84	16	64	45	20

**FINE FISSURED METRIC**

	Format	Dimensions (mm)	NRC (UL Classified)	CAC (UL Classified)	Recycled Content	UL Fire-Rated	LR	Pieces/carton	Sq. m/carton	Lbs./carton	Cartons/pallet		
<b>METRIC TRIM</b>													
	NRC 55x	HHF-2067M	Panels	500 x 1500 x 15	0.55	35	33%	—	0.84	8	6	52	20

\* Protectone®: A fire-resistive ceiling when used in applicable UL assemblies. Protectone product is indicated by a Yes in the UL Fire-Rated column. To specify color other than white, order by item number followed by color code. Example: HHF-154 BEB. Color List: Beige Breeze – BEB, Blondewood – BLW, Silver Lining – SIL, Wet Clay – WEC, White Wash – WIW. Only available for HHF-154, HHF-157, HHF-197, and FFCL-224 products.

**CAN'T FIND A SIZE?** Contact your local Sales Representative or call 800-233-8990

**FINE FISSURED | FINE FISSURED HIGH NRC | FINE FISSURED CUSTOMLINE®**

Fissured  
Mineral Fiber

All products in this line feature these attributes:



**FINE FISSURED CUSTOMLINE**

	Format	Dimensions (in.)	NRC (UL Classified)	CAC (UL Classified)	Recycled Content	UL Fire-Rated	LR	Pieces/ carton	Sq. Ft./ carton	Lbs./ carton	Cartons/ pallet		
<b>REVEAL</b>													
	NRC 55	FFCL-224	Panels	24 x 48 x 3/4	0.55	38	33%	n/a	0.84	8	64	64	16
		FFCL-448	Panels	24 x 48 x 3/4	0.50	38	33%	n/a	0.84	8	64	60	16
	NRC 50	FFCL-812	Panels	24 x 48 x 3/4	0.50	38	33%	n/a	0.84	8	64	64	16
		PFCL-224	Panels	24 x 48 x 3/4	0.50	40	44%	Yes*	0.84	8	64	75	16
<b>NARROW REVEAL</b>													
	NRC 55	FFCLN-224	Panels	24 x 48 x 3/4	0.55	38	33%	n/a	0.84	8	64	64	16
		FFCLN-448	Panels	24 x 48 x 3/4	0.50	38	33%	n/a	0.84	8	64	60	16
	NRC 50	FFCLN-812	Panels	24 x 48 x 3/4	0.50	38	33%	n/a	0.84	8	64	64	16

\* Protectone®: A fire-resistive ceiling when used in applicable UL assemblies. Protectone product is indicated by a Yes in the UL Fire-Rated column. To specify color other than white, order by item number followed by color code. Example: HHF-154 BEB. Color List: Beige Breeze – BEB, Blondewood – BLW, Silver Lining – SIL, Wet Clay – WEC, White Wash – WIW. Only available for HHF-154, HHF-157, HHF-197, and FFCL-224 products.

**CAN'T FIND A SIZE?** Contact your local Sales Representative or call 800-233-8990

**PHYSICAL DATA**

**MATERIAL**  
Mineral Fiber

**ASTM E1264 CLASSIFICATION**  
Type III, Form 2, Pattern C E  
(Standard & High NRC)  
Type IV, Form 2, Pattern C E K (Customline)

**FIRE CLASS (ASTM E1264)**  
All are Class A per ASTM E84 & CAN S102  
Flame Spread: 25 or less  
Smoke Developed: 50 or less

**VOC EMISSIONS**  
Independently certified compliant with California Department of Public Health CDPH/EHLB/Standard Method Version 1.1, 2010.

**MOLD/MILDEW RESISTANCE**  
BioShield treatment included for added mold and mildew resistance.

**INSTALLATION CONSIDERATION**  
Differing manufacturing dates should not be mixed in a single ceiling.

**MAINTENANCE**  
Wipe with a soft cloth or vacuum with brush attachment.

**WARRANTY**  
10-year 104/90 Limited Warranty increases to 15 years when installed with CertainTeed Suspension Systems. Full warranty information can be found at [certainteed.com/ceilings](http://certainteed.com/ceilings).



Customer Support | [certainteed.com/ceilings](http://certainteed.com/ceilings) | 800-233-8990

LEED® is a registered trademark of the U.S. Green Building Council. © 8/19 CertainTeed Corporation.

**RAMIREZ CONTRACTING SERVICES INC.**

2180 Magnum Circle  
 Lincoln, NE 68522 US  
 4029377462  
 ramirez.drywall@hotmail.com

**Invoice****BILL TO**

HAUSMANN CONSTRUCTION  
 8885 EXECUTIVE WOODS DR  
 LINCOLN, NE 68512

INVOICE #	DATE	TOTAL DUE	TERMS	ENCLOSED
WOL2347	11/21/2023	\$15,320.00	Net 30	

**JOB#/NAME**

Woodbury - Sioux City T&M

ACTIVITY	QTY	RATE	AMOUNT
<b>Contract - Drywall Hang, Tape and Finish</b> Framing and drywall work October 31- November 17	260	38.00	9,880.00
<b>Non-Contract - General Labor</b> Cleaning work done week of November 12	170	32.00	5,440.00

BALANCE DUE

**\$15,320.00**





**Hausmann Construction, Inc.**  
2106 Taylor Ave, Suite 400  
Norfolk, Nebraska 68701  
P: (402) 371-8650

**Project: 21-068 Woodbury County - Law  
Enforcement Center**  
3701 28th St  
Sioux City, Iowa 51104

## RFI #519: Fire Rated Acoustical Ceilings - Area A

<b>Status</b>	Open		
<b>To</b>	Carole Cline (Goldberg Group Architects)	<b>From</b>	Nathan Thege (Hausmann Construction, Inc.) 2106 Taylor Ave, Suite 400 Norfolk, Nebraska 68701
<b>Date Initiated</b>	Oct 3, 2023	<b>Due Date</b>	Oct 10, 2023
<b>Location</b>			
<b>Cost Impact</b>	TBD	<b>Schedule Impact</b>	TBD
<b>Spec Section</b>			
<b>Drawing Number</b>	A1.11, A1.21, .M1.11, M1.23, EL1.11, EL1.21	<b>Reference</b>	
<b>Linked Drawings</b>			
<b>Received From</b>	Nathan Thege (Hausmann Construction, Inc.)		
<b>Copies To</b>	Shane Albrecht (The Baker Group), Kaleb Anderson (Hausmann Construction, Inc.), Klay Kasik (Hausmann Construction, Inc.), Kevin Rost (Goldberg Group Architects), David Tobar (Hausmann Construction, Inc.)		

### Activity

#### Question

**Question from Nathan Thege Hausmann Construction, Inc. on Monday, Oct 2, 2023 at 04:02 PM CDT**

Per conversations onsite with GGA, it is acceptable to install fire rated ceiling pads, fire blankets over diffuser, and pans over the light fixtures in the secured corridors in Area A (both Floors). Please see attached highlighted plan showing the extent of the fire rated ceilings. By doing so, it is our understanding that this will eliminate the need to finish CMU walls up to structure as well as eliminating the need to install fire caulking around penetrations (Please reference second highlighted drawing for these walls). Please confirm this method is acceptable to achieve 1 hour rating through these corridors without having to finish the highlighted CMU walls up to structure.

**Attachments**

[Fire Rated Diffusers.pdf](#), [Fire Rated Acoustical Ceiling Pads.pdf](#), [CMU Walls Not Up To Deck.pdf](#), [Code Plan Markup 9.26.23.pdf](#)

#### Official Response

**Response from Carole Cline Goldberg Group Architects on Monday, Oct 16, 2023 at 10:52 AM CDT**

Please see the attached RFI 519 response.

**Attachments**

[RFI 519 - Fire Rated Acoustical Ceilings - Area A \(Response\).pdf](#)

#### All Replies

**Response from Nathan Thege Hausmann Construction, Inc. on Wednesday, Oct 25, 2023 at 03:39 PM CDT**

Per discussions in the field on 10/24/23 and 10/25/23, the updated attached drawing is an acceptable method to modify the ceilings on both floors to achieve fire rating requirements. Please confirm.

Another item discussed onsite (Also within the attached drawing) was to lower the west side of Secure Corridor 1207 down to 8'-10" to hide the overhead plumbing within the ceiling. Please confirm this is acceptable.

**Attachments**

[Code Plan Updates- Wall Conflicts with MEP and PR#35R Adjustments 10.25.23-Revised.pdf](#)

**Response from Carole Cline Goldberg Group Architects** on Monday, Oct 16, 2023 at 10:52 AM CDT

Please see the attached RFI 519 response.

**Attachments**

[RFI 519 - Fire Rated Acoustical Ceilings - Area A \(Response\).pdf](#)

Per the site visit on 10.24.23 with Hausmann Construction and correspondence with Henry Henchal with the City of Sioux City the ceilings and smoke barriers may be modified from the original PR 35R design per the attached sketches (GGA SKETCH 01 and 02) to allow for the required area separations, fire damper install and deletion of additional fire rated chases due to conflicts with the installed HVAC ductwork, piping and electrical conduits.

KR

GGA 11.03.23



**Hausmann Construction, Inc.**  
2106 Taylor Ave, Suite 400  
Norfolk, Nebraska 68701  
P: (402) 371-8650

**Project: 21-068 Woodbury County - Law  
Enforcement Center**  
3701 28th St  
Sioux City, Iowa 51104

## RFI #519: Fire Rated Acoustical Ceilings - Area A

<b>Status</b>	Open		
<b>To</b>	Carole Cline (Goldberg Group Architects)	<b>From</b>	Nathan Thege (Hausmann Construction, Inc.) 2106 Taylor Ave, Suite 400 Norfolk, Nebraska 68701
<b>Date Initiated</b>	Oct 3, 2023	<b>Due Date</b>	Oct 10, 2023
<b>Location</b>			
<b>Cost Impact</b>	TBD	<b>Schedule Impact</b>	TBD
<b>Spec Section</b>			
<b>Drawing Number</b>	A1.11, A1.21, .M1.11, M1.23, EL1.11, EL1.21	<b>Reference</b>	
<b>Linked Drawings</b>			
<b>Received From</b>	Nathan Thege (Hausmann Construction, Inc.)		
<b>Copies To</b>	Shane Albrecht (The Baker Group), Kaleb Anderson (Hausmann Construction, Inc.), Klay Kasik (Hausmann Construction, Inc.), Kevin Rost (Goldberg Group Architects), David Tobar (Hausmann Construction, Inc.)		

### Activity

#### Question

**Question from Nathan Thege Hausmann Construction, Inc. on Monday, Oct 2, 2023 at 04:02 PM CDT**

Per conversations onsite with GGA, it is acceptable to install fire rated ceiling pads, fire blankets over diffuser, and pans over the light fixtures in the secured corridors in Area A (both Floors). Please see attached highlighted plan showing the extent of the fire rated ceilings. By doing so, it is our understanding that this will eliminate the need to finish CMU walls up to structure as well as eliminating the need to install fire caulking around penetrations (Please reference second highlighted drawing for these walls). Please confirm this method is acceptable to achieve 1 hour rating through these corridors without having to finish the highlighted CMU walls up to structure.

#### Attachments

[Fire Rated Diffusers.pdf](#), [Fire Rated Acoustical Ceiling Pads.pdf](#), [CMU Walls Not Up To Deck.pdf](#), [Code Plan Markup 9.26.23.pdf](#)

Per discussions in the field on 09.13.2023 and correspondence with Hausmann on 10.12.2023, fire rated ceilings may be installed at Corridor 1162B in lieu of fire-sealing top of wall and above-ceiling penetrations within the 60 min. fire barrier surrounding this corridor. The 120 min. fire barrier is not included in this exception, and will require fire-sealing as originally called for in the drawings and specifications. Please indicate if this option is still wanting to be considered and we will reach out to the AHJ.

C. Cline  
GGA  
10.16.2023



# TB-24

## Mineral Wool Thermal Blanket 3 Hour Fire Resistance Rating

### Application

TB-24 is a non-asbestos mineral wool thermal blanket. This mineral wool thermal blanket material is listed with UL to be used as an accessory to Greenheck's ceiling radiation dampers or to be used as a batt and blanket material.

### Specifications

#### Size

24 in. x 24 in. x 1 1/2 in. (610mm x 610mm x 38mm)

#### Cut-out

5 in. (127mm) diameter. May be cut for larger diffuser necks.

#### Material

Non-asbestos mineral wool

#### Density

3 1/2 lb/ft<sup>3</sup> (56 kg/m<sup>3</sup>)

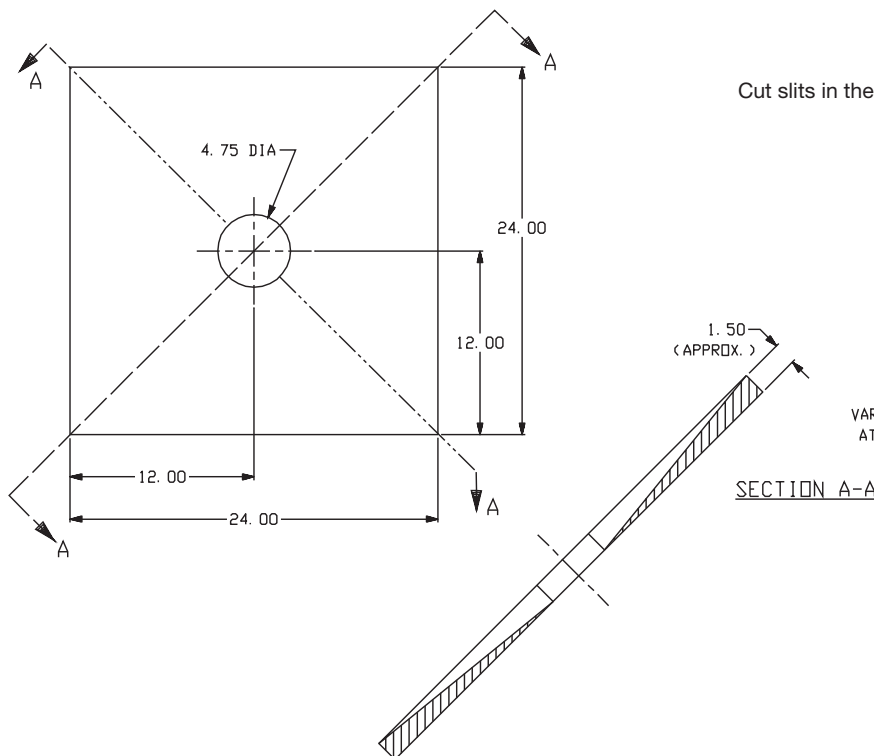
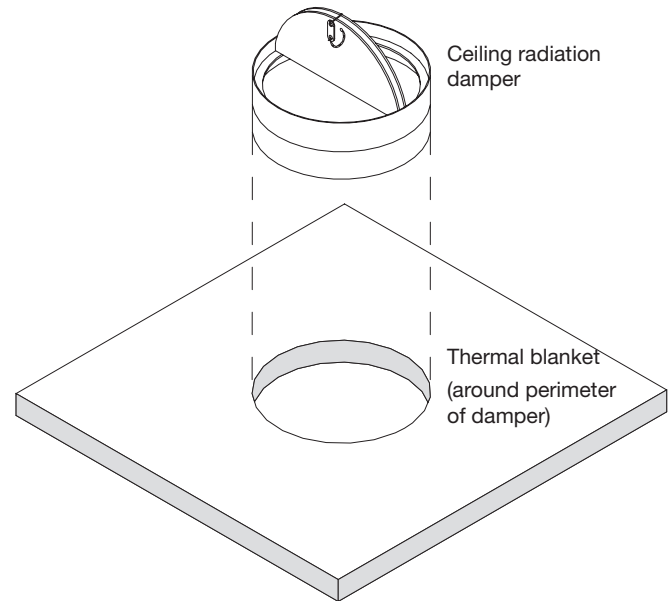

Cut slits in the blanket so it lays flat on top of the diffuser.



# B1 LOUVERED FACE DIFFUSERS

1400FR | 4-Cone, Fire Rated

## 1400FR Suggested Specification & Configuration

### 1400FR

The drop cone, square face diffuser shall be Krueger model 1400FR (steel). The diffuser must be UL classified fire rated ceiling diffuser assembly listed in Underwriters Laboratories Fire Resistance Directory. The diffuser shall be tested in accordance with UL 263 and must meet NFPA 90 requirements. The diffuser must be able to operate in three-hour fire rated, exposed grid suspended ceiling. The 1400FR model shall be constructed of four precision die-stamped cones. The back cone shall have an integrally drawn neck for duct connections. Welded-in inlets and corner joints are not acceptable. The inner cone assembly shall be welded to the back cone. Diffusers shall be constructed of 22 gage steel.

### PERFORMANCE

The manufacturer shall provide published (printed or electronic) performance data for the diffuser. Performance data shall include 2 - 7 octave band sound power levels. The diffuser shall be tested in accordance to the data standards at the time of product introduction or ANSI/ASHRAE Standard 70.

### FINISH

The paint finish shall be #44 British White and be an anodic acrylic paint, baked at 315° for 30 minutes. The paint thickness shall be 0.8 - 1.0 mils, gloss at 60° per ASTM D523-89 of 50 - 85%, pencil hardness per ASTM D3363-92A of HB - H, crosshatch adhesion per ASTM D3359-83 of 4B - 5B, impact per ASTM D2794-93 of direct impact >100 in/lb and reverse impact >80 in/lb, salt spray per ASTM B117-9048 of 96 hours, humidity per ASTM D2247-92 of >500 hours and water soak per ASTM D870-92 of 250 hours.

- 1. **SERIES: (XXXXXX)**  
1400FR - 4-Cone, Steel, Fire Rated Ceiling Diffuser
- 2. **ROUND NECK: (XX)**  
6", 8", 10", 12", 14", or 15"
- 3. **FRAME: (XXX)**  
F23 - Lay-in T-Bar
- 4. **PANEL: (XX)x(XX)**  
24"x24"
- 5. **FINISH: (XX)**  
44 - British White

LOUVERED FACE DIFFUSERS

1  
4  
0  
0  
F  
R

**SAMPLE CONFIGURATION: 1400FR - 10 - F23 - 24x24 - 44**

**SUBMITTAL SHEET**

Form Number DS1406.3 Effective Date 1/01  
replaces DS1406.2

JOB NAME \_\_\_\_\_  
 ARCHITECT \_\_\_\_\_  
 ENGINEER \_\_\_\_\_  
 CONTRACTOR \_\_\_\_\_  
 LOCATION \_\_\_\_\_



**SERIES 1400FR - 'UL' FIRE RATED  
 SQUARE FACE - ROUND NECK DIFFUSERS**

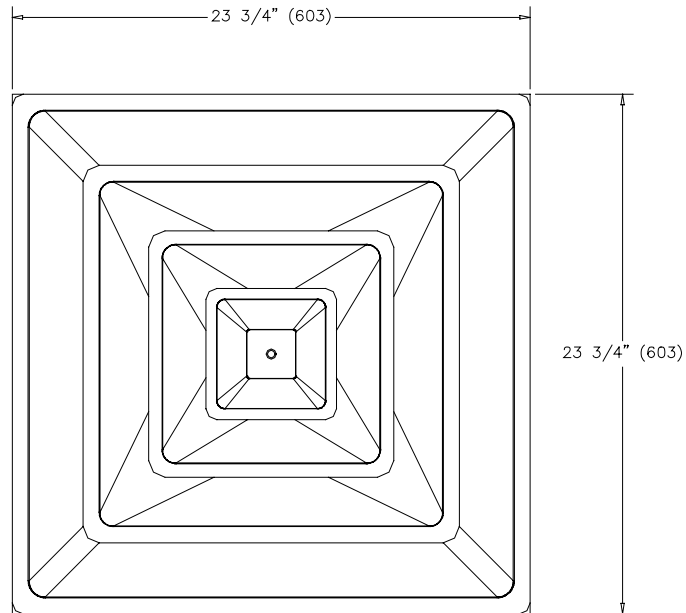

**DIMENSIONS ARE GIVEN AS  
 INCHES (MM)**

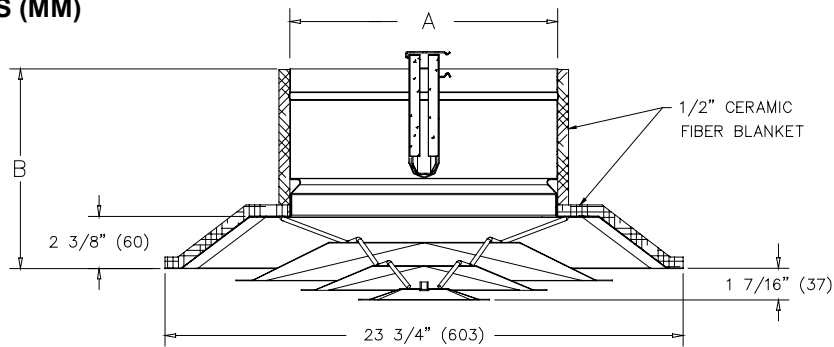

NOMINAL NECK SIZE	A	B
6	5 7/8" (149)	10 1/16" (256)
8	7 7/8" (200)	9 15/16" (252)
10	9 7/8" (251)	10 7/16" (265)
12	11 7/8" (302)	12 7/16" (316)
14	13 7/8" (352)	12 7/16" (316)
15	14 7/8" (378)	15 7/16" (392)

**NOTES :**

1. Unit is for a lay-in type ceiling.
2. **1400FR** series is steel construction.
3. All models come with two earthquake tabs.
4. Standard finish is 44 white

**ACCESSORIES :**

- Standard **1400FR** is a UL classified assembly that incorporates a three hour rated fire damper and a 1/2" thick ceramic fire blanket.

Mineral Fiber Ceilings

## Baroque™

Mineral Fiber Ceilings

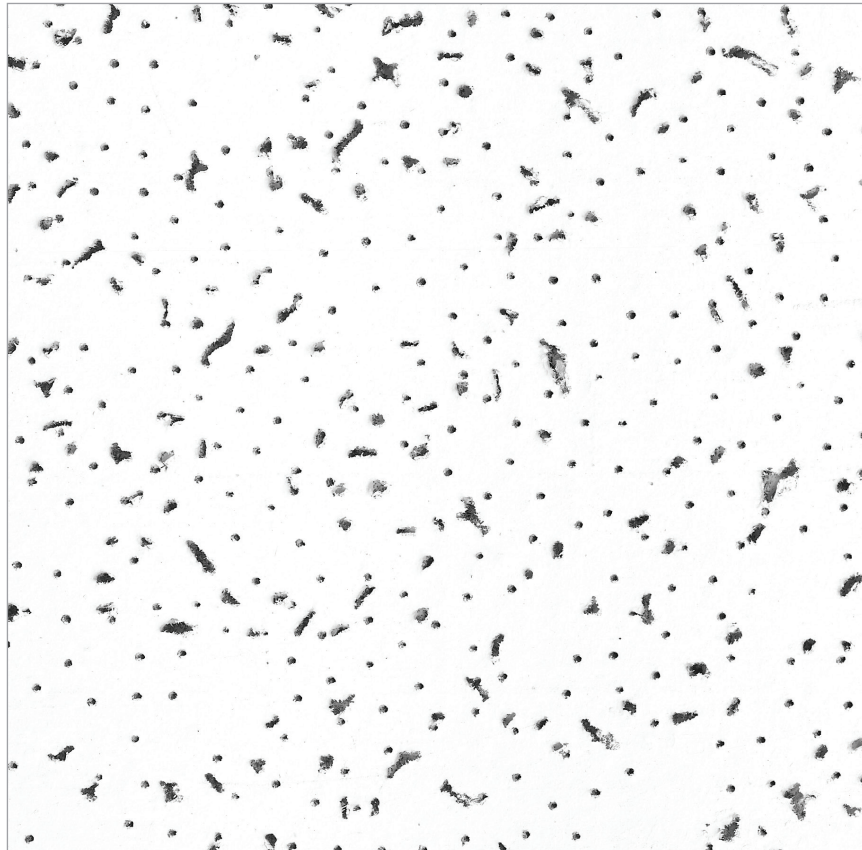

LOW VOC

\$\$\$\$



### LEED® v4

- MR: Environmental Product Declarations (EPDs)
- MR: Sourcing Raw Materials
- MR: Material Ingredients (HPDs)
- IEQ: Daylight
- IEQ: Low-Emitting Materials
- IEQ: Prereq. Min. Acoustic Performance (Schools)
- IEQ: Acoustic Performance
- MR: PBT Source Reduction (Healthcare)
- IEQ: Interior Lighting
- EA: Prereq. Min. Energy Performance
- EA: Optimize Energy Performance

**Recycled Content**

<input checked="" type="radio"/> CLASS A	Pre: <b>28%</b>	Post: <b>2%</b>
PROTECTONE®	Pre: <b>37%</b>	Post: <b>1%</b>

### TOOLS

Visit [CertainTeed.com/Ceilings](http://CertainTeed.com/Ceilings)  
Download HPDs and EPDs  
LEED® Information / BIM Objects  
3-Part Specs / Data Pages

### FEATURES & BENEFITS

- 100% non-directional fissured pattern
- Higher sound absorption than comparable products
- Third-party verified Environmental Product Declaration (EPD) available for this product
- Available in fire-rated (Protectone®) version
- Health Product Declaration (HPD) available for this product

### APPLICATIONS

- Utility Areas
- Retail Warehouses
- Strip Malls
- Commercial Interior Spaces
- Offices
- Other Commercial Buildings / Space Applications



Carbon Footprint Reduction  
Rapidly Renewable Resource Content  
Recycled Content



EPD Available



HPD Available

### AVAILABLE EDGE DETAILS



Trim  
15/16 Grid



Reveal Beveled  
15/16 Grid



Narrow Reveal Corner Bevel  
9/16 Grid



Narrow Reveal Corner Bevel  
9/16 Grid Bolt Slot



Baroque™ Reveal (BET-154)

**ATTRIBUTES**

	DIMENSIONS INCHES	EDGE DETAIL	UL CLASSIFIED NRC	CAC	EPD AVAILABLE	HPD AVAILABLE	SAG RESISTANT	MOLD RESISTANT	LR	WASHABLE	FIRE CLASS ASTM E1264	EMISSION COMPLIANT	RECYCLED CONTENT
<b>BAROQUE™</b>													
<b>BET-157</b>	24 x 24 x 5/8	Trim	0.60	33	Yes	Yes	—	—	0.83	—	Class A	Certified	30%
<b>PBT-157</b>	24 x 24 x 5/8	Trim	0.55	35	Yes	Yes	—	—	0.83	—	Protectone*	Certified	38%
<b>BET-154</b>	24 x 24 x 5/8	Reveal	0.60	33	Yes	Yes	—	—	0.83	—	Class A	Certified	30%
<b>PBT-154</b>	24 x 24 x 5/8	Reveal	0.55	35	Yes	Yes	—	—	0.83	—	Protectone*	Certified	38%
<b>BET-150</b>	24 x 24 x 5/8	Narrow Reveal	0.60	33	Yes	Yes	—	—	0.83	—	Class A	Certified	30%
<b>BET-197</b>	24 x 48 x 5/8	Trim	0.60	35	Yes	Yes	—	—	0.83	—	Class A	Certified	30%
<b>PBT-197</b>	24 x 48 x 5/8	Trim	0.55	40	Yes	Yes	—	—	0.83	—	Protectone*	Certified	38%
<b>BET-194</b>	24 x 48 x 5/8	Reveal	0.60	35	Yes	Yes	—	—	0.83	—	Class A	Certified	30%
<b>BET-2067</b>	20 x 60 x 5/8	Trim	0.60	35	Yes	Yes	—	—	0.83	—	Class A	Certified	30%

**BAROQUE™ – METRIC**

<b>BET-2067M</b>	(500 x 1500 x 15)	Trim	0.60	35	Yes	Yes	—	—	0.83	—	Class A	Certified	30%
------------------	-------------------	------	------	----	-----	-----	---	---	------	---	---------	-----------	-----

\*Protectone\*: A fire-resistive ceiling when used in applicable UL assemblies.

**CAN'T FIND A SIZE?** Contact your local Sales Representative or call 800-233-8990

**PHYSICAL DATA**

**MATERIAL**

Mineral Fiber

**ASTM E1264 CLASSIFICATION**

Type III, Form 2, Pattern C D

**FIRE CLASS (ASTM E1264)**

Tested according to ASTM E84 & CAN S102

Flame Spread: 25 or less

Smoke Developed: 50 or less

**VOC EMISSIONS**

Independently certified compliant with California Department of Public Health CDPH/EHLB/Standard Method Version 1.1, 2010.

**MAINTENANCE**

Wipe with a soft cloth or vacuum with brush attachment.

**WARRANTY**

1-year Limited Warranty

Technical Support | [certainteed.com/ceilings](http://certainteed.com/ceilings) 800-233-8990

© 05/18 CertainTeed Corporation





Fissured  
Mineral Fiber

A non-directional mineral fiber panel for all-around workability, affordability and great-looking installations.



### APPLICATIONS

- Schools / Classrooms
- Libraries / Media Centers
- Retail / Department Stores
- Offices
- Open Plan Areas
- Healthcare Spaces – High NRC
- Computer Rooms – High NRC
- Other Commercial Buildings / Space Applications

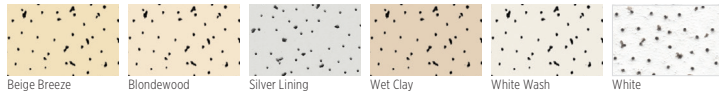

### FEATURES AND BENEFITS

- Non-directional fissured pattern
- Cuts cleanly, leading to quicker installation and lower installation costs
- High NRC panels are excellent for budgeted projects requiring high sound absorption
- High NRC panels comply with LEED v4 for School classroom acoustics prerequisite
- Customline options provide three dramatic geometric designs with discreet small-scale fissure pattern
- Deep face-scoring assists in masking the presence of metal grid on Customline products
- High humidity and sag resistant
- Some products available in fire-rated (Protectone) versions
- Environmental Product Declaration (EPD) available for this product
- Health Product Declaration (HPD) available for this product
- Available in 6 standard colors for item numbers HHF-154, HHF-157, HHF-197, FFCL-224
- High NRC has USDA Certified Biobased content of 98%

### SUSPENSION SYSTEM OPTIONS

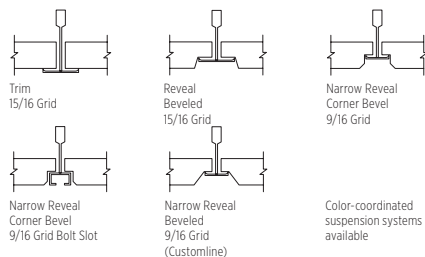

### CUSTOMLINE SCORING OPTIONS

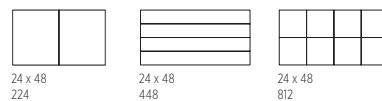

### LEED® v4

#### RECYCLED CONTENT

<b>CLASS A</b>	<b>33 - 70%</b>
<b>PROTECTONE®</b>	<b>44%</b>

- EA: Optimize Energy Performance
- EA: Prereq. Min. Energy Performance
- EQ: Interior Lighting
- MR: PBT Source Reduction (Healthcare)
- EQ: Acoustic Performance
- EQ: Prereq. Min. Acoustic Performance (Schools) *Applies only to High NRC*
- EQ: Low-Emitting Materials
- EQ: Daylight
- MR: Material Ingredients (HPDs)
- MR: Sourcing Raw Materials
- MR: Environmental Product Declarations (EPDs)
- MR: Construction and Demolition Waste Management Planning



EPD Available



HPD Available



Recycled Content



High NRC Only

**CertainTeed**  
SAINT-GOBAIN

Customer Support | [certainteed.com/ceilings](http://certainteed.com/ceilings) | 800-233-8990

**FINE FISSURED | FINE FISSURED HIGH NRC | FINE FISSURED CUSTOMLINE®**

Fissured  
Mineral Fiber

All products in this line feature these attributes:



**FINE FISSURED HIGH NRC**

		Format	Dimensions (in.)	NRC (UL Classified)	CAC (UL Classified)	Recycled Content	UL Fire-Rated	LR	Pieces/carton	Sq. Ft./carton	Lbs./carton	Cartons/pallet	
<b>TRIM</b>													
	NRC 70	HHF-457 HNRC	Panels	24 x 24 x 3/4	0.70	35	70%	—	0.83	14	56	55	16
		HHF-497 HNRC	Panels	24 x 48 x 3/4	0.70	35	70%	—	0.83	8	64	62	16
<b>REVEAL</b>													
	NRC 70	HHF-454 HNRC	Panels	24 x 24 x 3/4	0.70	35	70%	—	0.83	14	56	55	16
		HHF-494 HNRC	Panels	24 x 48 x 3/4	0.70	35	70%	—	0.83	8	64	62	16

**FINE FISSURED**

		Format	Dimensions (in.)	NRC (UL Classified)	CAC (UL Classified)	Recycled Content	UL Fire-Rated	LR	Pieces/carton	Sq. Ft./carton	Lbs./carton	Cartons/pallet	
<b>TRIM</b>													
	NRC 55	HHF-157	Panels	24 x 24 x 5/8	0.55	33	33%	—	0.84	16	64	50	20
		PFF-157	Panels	24 x 24 x 5/8	0.55	35	44%	Yes*	0.84	16	64	70	20
		HHF-197	Panels	24 x 48 x 5/8	0.55	35	33%	—	0.84	8	64	45	20
		PFF-197	Panels	24 x 48 x 5/8	0.55	40	44%	Yes*	0.84	8	64	70	20
		HHF-177	Panels	20 x 48 x 5/8	0.55	35	33%	—	0.84	8	80	51	20
		HHF-2067	Panels	20 x 60 x 5/8	0.55	35	33%	—	0.84	8	66.7	52	16
<b>REVEAL</b>													
	NRC 55	HHF-154	Panels	24 x 24 x 5/8	0.55	33	33%	—	0.84	16	64	45	20
		PFF-154	Panels	24 x 24 x 5/8	0.55	35	44%	Yes*	0.84	16	64	70	20
		HHF-194	Panels	24 x 48 x 5/8	0.55	35	33%	—	0.84	8	64	45	20

**NARROW REVEAL**

	NRC 55	HHF-150	Panels	24 x 24 x 5/8	0.55	35	33%	—	0.84	16	64	45	20
--	--------	---------	--------	---------------	------	----	-----	---	------	----	----	----	----

**FINE FISSURED METRIC**

		Format	Dimensions (mm)	NRC (UL Classified)	CAC (UL Classified)	Recycled Content	UL Fire-Rated	LR	Pieces/carton	Sq. m/carton	Lbs./carton	Cartons/pallet	
<b>METRIC TRIM</b>													
	NRC 55x	HHF-2067M	Panels	500 x 1500 x 15	0.55	35	33%	—	0.84	8	6	52	20

\* Protectone®: A fire-resistive ceiling when used in applicable UL assemblies. Protectone product is indicated by a Yes in the UL Fire-Rated column.

To specify color other than white, order by item number followed by color code. Example: HHF-154 BEB. Color List: Beige Breeze – BEB, Blondewood – BLW, Silver Lining – SIL, Wet Clay – WEC, White Wash – WIW. Only available for HHF-154, HHF-157, HHF-197, and FFCL-224 products.

**CAN'T FIND A SIZE?** Contact your local Sales Representative or call 800-233-8990

**FINE FISSURED | FINE FISSURED HIGH NRC | FINE FISSURED CUSTOMLINE®**

Fissured  
Mineral Fiber

All products in this line feature these attributes:



**FINE FISSURED CUSTOMLINE**

	Format	Dimensions (in.)	NRC (UL Classified)	CAC (UL Classified)	Recycled Content	UL Fire-Rated	LR	Pieces/ carton	Sq. Ft./ carton	Lbs./ carton	Cartons/ pallet		
<b>REVEAL</b>													
	NRC 55	FFCL-224	Panels	24 x 48 x 3/4	0.55	38	33%	n/a	0.84	8	64	64	16
		FFCL-448	Panels	24 x 48 x 3/4	0.50	38	33%	n/a	0.84	8	64	60	16
	NRC 50	FFCL-812	Panels	24 x 48 x 3/4	0.50	38	33%	n/a	0.84	8	64	64	16
		PFCL-224	Panels	24 x 48 x 3/4	0.50	40	44%	Yes*	0.84	8	64	75	16
<b>NARROW REVEAL</b>													
	NRC 55	FFCLN-224	Panels	24 x 48 x 3/4	0.55	38	33%	n/a	0.84	8	64	64	16
		FFCLN-448	Panels	24 x 48 x 3/4	0.50	38	33%	n/a	0.84	8	64	60	16
	NRC 50	FFCLN-812	Panels	24 x 48 x 3/4	0.50	38	33%	n/a	0.84	8	64	64	16

\* Protectone®: A fire-resistive ceiling when used in applicable UL assemblies. Protectone product is indicated by a Yes in the UL Fire-Rated column.  
To specify color other than white, order by item number followed by color code. Example: HHF-154 BEB. Color List: Beige Breeze – BEB, Blondewood – BLW, Silver Lining – SIL, Wet Clay – WEC, White Wash – WIW.  
Only available for HHF-154, HHF-157, HHF-197, and FFCL-224 products.

**CAN'T FIND A SIZE?** Contact your local Sales Representative or call 800-233-8990

**PHYSICAL DATA**

**MATERIAL**  
Mineral Fiber

**ASTM E1264 CLASSIFICATION**  
Type III, Form 2, Pattern C E  
(Standard & High NRC)  
Type IV, Form 2, Pattern C E K (Customline)

**FIRE CLASS (ASTM E1264)**  
All are Class A per ASTM E84 & CAN S102  
Flame Spread: 25 or less  
Smoke Developed: 50 or less

**VOC EMISSIONS**  
Independently certified compliant with California Department of Public Health CDPH/EHLB/Standard Method Version 1.1, 2010.

**MOLD/MILDEW RESISTANCE**  
BioShield treatment included for added mold and mildew resistance.

**INSTALLATION CONSIDERATION**  
Differing manufacturing dates should not be mixed in a single ceiling.

**MAINTENANCE**  
Wipe with a soft cloth or vacuum with brush attachment.

**WARRANTY**  
10-year 104/90 Limited Warranty increases to 15 years when installed with CertainTeed Suspension Systems. Full warranty information can be found at [certainteed.com/ceilings](http://certainteed.com/ceilings).



Customer Support | [certainteed.com/ceilings](http://certainteed.com/ceilings) | 800-233-8990

LEED® is a registered trademark of the U.S. Green Building Council. © 8/19 CertainTeed Corporation.

**Certificate Of Completion**

Envelope Id: 41B74CCE581241EDAEAEF00646D82D82	Status: Sent
Subject: 21-068 Woodbury - #PCO 109 R3 - RFI #519 - Fire ceilings - FOR APPROVAL	
Source Envelope:	
Document Pages: 37	Signatures: 2
Certificate Pages: 5	Initials: 1
AutoNav: Enabled	Envelope Originator:
Envelope Stamping: Enabled	Amy Ahlers
Time Zone: (UTC-06:00) Central Time (US & Canada)	8885 Executive Woods Drive
	Lincoln, NE 68512
	amy@hausmannconstruction.com
	IP Address: 34.225.141.179

**Record Tracking**

Status: Original	Holder: Amy Ahlers	Location: DocuSign
2/7/2024 4:10:24 PM	amy@hausmannconstruction.com	

**Signer Events**

Klay Kasik  
 klayk@hausmannconstruction.com  
 Sr. Project Manager  
 Hausmann Construction  
 Security Level: Email, Account Authentication (None)

**Signature**



Signature Adoption: Pre-selected Style  
 Using IP Address: 174.228.35.101  
 Signed using mobile

**Timestamp**

Sent: 2/7/2024 4:14:49 PM  
 Viewed: 2/7/2024 5:33:11 PM  
 Signed: 2/7/2024 5:33:45 PM

**Electronic Record and Signature Disclosure:**  
 Not Offered via DocuSign

Steve Thiele  
 stevet@hausmannconstruction.com  
 Vice President  
 Hausmann Construction, Inc.  
 Security Level: Email, Account Authentication (None)



Signature Adoption: Pre-selected Style  
 Using IP Address: 209.50.13.227

Sent: 2/7/2024 5:33:54 PM  
 Viewed: 2/7/2024 10:27:27 PM  
 Signed: 2/8/2024 10:55:30 AM

**Electronic Record and Signature Disclosure:**  
 Not Offered via DocuSign

Kevin Rost  
 kevin.r@gga.llc  
 Security Level: Email, Account Authentication (None)

Sent: 2/8/2024 10:55:39 AM

**Electronic Record and Signature Disclosure:**  
 Accepted: 2/1/2024 1:58:47 PM  
 ID: e5dafd7c-4450-4373-a27c-727778ee91b7

Ron Wieck  
 rwieck65@gmail.com  
 Security Level: Email, Account Authentication (None)

**Electronic Record and Signature Disclosure:**  
 Accepted: 12/6/2022 6:20:49 PM  
 ID: cb840872-8216-42eb-9ac6-0ad45abc3082

In Person Signer Events	Signature	Timestamp
Editor Delivery Events	Status	Timestamp
Agent Delivery Events	Status	Timestamp
Intermediary Delivery Events	Status	Timestamp

Certified Delivery Events	Status	Timestamp
<b>Carbon Copy Events</b> Shane Albrecht albrechts@thebakergroup.com Security Level: Email, Account Authentication (None) <b>Electronic Record and Signature Disclosure:</b> Not Offered via DocuSign	<div style="border: 2px solid blue; padding: 5px; font-weight: bold; color: blue; font-size: 1.2em;">COPIED</div>	Sent: 2/8/2024 10:55:40 AM
Todd Wieck wieckt@TheBakerGroup.com Security Level: Email, Account Authentication (None) <b>Electronic Record and Signature Disclosure:</b> Not Offered via DocuSign	<div style="border: 2px solid blue; padding: 5px; font-weight: bold; color: blue; font-size: 1.2em;">COPIED</div>	Sent: 2/8/2024 10:55:40 AM Viewed: 2/8/2024 11:02:18 AM
Shane Albrecht albrechts@thebakergroup.com Security Level: Email, Account Authentication (None) <b>Electronic Record and Signature Disclosure:</b> Not Offered via DocuSign		
Todd Wieck wieckt@TheBakerGroup.com Security Level: Email, Account Authentication (None) <b>Electronic Record and Signature Disclosure:</b> Not Offered via DocuSign		
Witness Events	Signature	Timestamp
Notary Events	Signature	Timestamp
Envelope Summary Events	Status	Timestamps
Envelope Sent	Hashed/Encrypted	2/7/2024 4:14:49 PM
Payment Events	Status	Timestamps
Electronic Record and Signature Disclosure		

## **ELECTRONIC RECORD AND SIGNATURE DISCLOSURE**

From time to time, Hausmann Construction, Inc. (we, us or Company) may be required by law to provide to you certain written notices or disclosures. Described below are the terms and conditions for providing to you such notices and disclosures electronically through the DocuSign system. Please read the information below carefully and thoroughly, and if you can access this information electronically to your satisfaction and agree to this Electronic Record and Signature Disclosure (ERSD), please confirm your agreement by selecting the check-box next to 'I agree to use electronic records and signatures' before clicking 'CONTINUE' within the DocuSign system.

### **Getting paper copies**

At any time, you may request from us a paper copy of any record provided or made available electronically to you by us. You will have the ability to download and print documents we send to you through the DocuSign system during and immediately after the signing session and, if you elect to create a DocuSign account, you may access the documents for a limited period of time (usually 30 days) after such documents are first sent to you. After such time, if you wish for us to send you paper copies of any such documents from our office to you, you will be charged a \$0.00 per-page fee. You may request delivery of such paper copies from us by following the procedure described below.

### **Withdrawing your consent**

If you decide to receive notices and disclosures from us electronically, you may at any time change your mind and tell us that thereafter you want to receive required notices and disclosures only in paper format. How you must inform us of your decision to receive future notices and disclosure in paper format and withdraw your consent to receive notices and disclosures electronically is described below.

### **Consequences of changing your mind**

If you elect to receive required notices and disclosures only in paper format, it will slow the speed at which we can complete certain steps in transactions with you and delivering services to you because we will need first to send the required notices or disclosures to you in paper format, and then wait until we receive back from you your acknowledgment of your receipt of such paper notices or disclosures. Further, you will no longer be able to use the DocuSign system to receive required notices and consents electronically from us or to sign electronically documents from us.

### **All notices and disclosures will be sent to you electronically**

Unless you tell us otherwise in accordance with the procedures described herein, we will provide electronically to you through the DocuSign system all required notices, disclosures, authorizations, acknowledgements, and other documents that are required to be provided or made available to you during the course of our relationship with you. To reduce the chance of you inadvertently not receiving any notice or disclosure, we prefer to provide all of the required notices and disclosures to you by the same method and to the same address that you have given us. Thus, you can receive all the disclosures and notices electronically or in paper format through the paper mail delivery system. If you do not agree with this process, please let us know as described below. Please also see the paragraph immediately above that describes the consequences of your electing not to receive delivery of the notices and disclosures electronically from us.

### **How to contact Hausmann Construction, Inc.:**

You may contact us to let us know of your changes as to how we may contact you electronically, to request paper copies of certain information from us, and to withdraw your prior consent to receive notices and disclosures electronically as follows:

To contact us by email send messages to: [nateg@hausmannconstruction.com](mailto:nateg@hausmannconstruction.com)

### **To advise Hausmann Construction, Inc. of your new email address**

To let us know of a change in your email address where we should send notices and disclosures electronically to you, you must send an email message to us at [nateg@hausmannconstruction.com](mailto:nateg@hausmannconstruction.com) and in the body of such request you must state: your previous email address, your new email address. We do not require any other information from you to change your email address.

If you created a DocuSign account, you may update it with your new email address through your account preferences.

### **To request paper copies from Hausmann Construction, Inc.**

To request delivery from us of paper copies of the notices and disclosures previously provided by us to you electronically, you must send us an email to [nateg@hausmannconstruction.com](mailto:nateg@hausmannconstruction.com) and in the body of such request you must state your email address, full name, mailing address, and telephone number. We will bill you for any fees at that time, if any.

### **To withdraw your consent with Hausmann Construction, Inc.**

To inform us that you no longer wish to receive future notices and disclosures in electronic format you may:

i. decline to sign a document from within your signing session, and on the subsequent page, select the check-box indicating you wish to withdraw your consent, or you may;

ii. send us an email to [nateg@hausmannconstruction.com](mailto:nateg@hausmannconstruction.com) and in the body of such request you must state your email, full name, mailing address, and telephone number. We do not need any other information from you to withdraw consent.. The consequences of your withdrawing consent for online documents will be that transactions may take a longer time to process..

### **Required hardware and software**

The minimum system requirements for using the DocuSign system may change over time. The current system requirements are found here: <https://support.docusign.com/guides/signer-guide-signing-system-requirements>.

### **Acknowledging your access and consent to receive and sign documents electronically**

To confirm to us that you can access this information electronically, which will be similar to other electronic notices and disclosures that we will provide to you, please confirm that you have read this ERSD, and (i) that you are able to print on paper or electronically save this ERSD for your future reference and access; or (ii) that you are able to email this ERSD to an email address where you will be able to print on paper or save it for your future reference and access. Further, if you consent to receiving notices and disclosures exclusively in electronic format as described herein, then select the check-box next to ‘I agree to use electronic records and signatures’ before clicking ‘CONTINUE’ within the DocuSign system.

By selecting the check-box next to ‘I agree to use electronic records and signatures’, you confirm that:

- You can access and read this Electronic Record and Signature Disclosure; and
- You can print on paper this Electronic Record and Signature Disclosure, or save or send this Electronic Record and Disclosure to a location where you can print it, for future reference and access; and
- Until or unless you notify Hausmann Construction, Inc. as described above, you consent to receive exclusively through electronic means all notices, disclosures, authorizations, acknowledgements, and other documents that are required to be provided or made available to you by Hausmann Construction, Inc. during the course of your relationship with Hausmann Construction, Inc..





**PCO #PCO121**

Hausmann Construction, Inc.  
 2106 Taylor Ave, Suite 400  
 Norfolk, Nebraska 68701  
 Phone: (402) 371-8650

**Project:** 21-068 - Woodbury County - Law Enforcement Center  
 3701 28th St  
 Sioux City, Iowa 51104

**Prime Contract Potential Change Order #PCO121: CE #PCO 121 - RFI 555**

<b>TO:</b>	Woodbury County Law Enforcement 620 Douglas Street Sioux City, Iowa 51105	<b>FROM:</b>	Hausmann Construction, Inc. 8885 Executive Woods Drive Lincoln, Nebraska 68512
<b>PCO NUMBER/REVISION:</b>	PCO121 / 0	<b>CONTRACT:</b>	21-068 - Woodbury County - Law Enforcement Center
<b>REQUEST RECEIVED FROM:</b>		<b>CREATED BY:</b>	Klay Kasik (Hausmann Construction, Inc.)
<b>STATUS:</b>	Pending - In Review	<b>CREATED DATE:</b>	1/19/2024
<b>REFERENCE:</b>		<b>PRIME CONTRACT CHANGE ORDER:</b>	None
<b>FIELD CHANGE:</b>	No		
<b>LOCATION:</b>		<b>ACCOUNTING METHOD:</b>	Amount Based
<b>SCHEDULE IMPACT:</b>		<b>PAID IN FULL:</b>	No
<b>EXECUTED:</b>	No	<b>SIGNED CHANGE ORDER RECEIVED DATE:</b>	
		<b>TOTAL AMOUNT:</b>	\$2,099.00

**POTENTIAL CHANGE ORDER TITLE:** CE #PCO 121 - RFI 555

**CHANGE REASON:** Design Development

**POTENTIAL CHANGE ORDER DESCRIPTION:** *(The Contract Is Changed As Follows)*

CE #PCO 121 - RFI 555

PCO 121 is created to incorporate the costs associated with RFI 555 as itemized within. Please provide approval no later than February 2, 2024. Also please note that we are not waiving our right to include costs for General Conditions due to concurrent changes that are concurrently being priced. In the event that other change orders are not approved in their entirety (PR 35R & PR 38) this PCO will be subjected to additional general conditions.

**ATTACHMENTS:**

[Estimate - Woodbury County LEC - Hausmann - COR#06.pdf](#) , [RFI 555 - Door Opening 0016-3 \(Response\) \(1\).pdf](#) , [21-068 -CO BACK UP 12.2223.pdf](#)

#	Description	Amount
1	Hausmann	\$752.00
2	Blankenship	\$1,190.00
3	Fees	\$136.00
4	Bond & Insurance	\$21.00
<b>Grand Total:</b>		<b>\$2,099.00</b>

**Kevin Rost (Goldberg Group Architects)**  
 520 Francis Street Suite 200C  
 St. Joseph, Missouri 64501

**Woodbury County Law Enforcement**  
 620 Douglas Street  
 Sioux City, Iowa 51105

**Hausmann Construction, Inc.**  
 8885 Executive Woods Drive  
 Lincoln, Nebraska 68512

DocuSigned by:

*Klay Kasik*

1/19/2024

B96656CE885642A...

SIGNATURE

DATE

SIGNATURE

DATE

SIGNATURE

DATE





# Estimate

Date: January 8, 2024

701 N. Derby Ln.  
 N. Sioux City, SD 57049  
 712-255-9197

To: Hausmann Construction  
 Klay Kasik  
 8885 Executive Woods Dr.  
 Lincoln, NE 68512

Description	Total
Re: Woodbury County LEC Sioux City, IA	
<b><u>Change Order Request: 06</u></b>	\$ 1,190.00
Add brake metal flashing to 0016 entrance	
<b>Subtotal</b>	<b>\$ 1,190.00</b>
<b>Sales Tax</b>	<b>-</b>
<b>Total</b>	<b>\$ 1,190.00</b>

\*\*Owner shall pay all amounts due and owing under this proposal when due. The due date for the full payment due hereunder shall be 30 days after the invoice date. All amounts past due shall bear interest at the rate of 5% per annum until paid in full. Owner shall pay on demand all costs and expenses incurred by contractor in enforcing or protecting its rights under this contract, including, but not limited to, reasonable attorneys' fees and legal expenses.\*\*

Customer Signature Of Acceptance

Thank you for your business!



Hausmann Construction, Inc.  
2106 Taylor Ave, Suite 400  
Norfolk, Nebraska 68701  
P: (402) 371-8650

Project: 21-068 Woodbury County - Law  
Enforcement Center  
3701 28th St  
Sioux City, Iowa 51104

## RFI #555: Door Opening 0016-3

<b>Status</b>	Open		
<b>To</b>	Kevin Rost (Goldberg Group Architects) Carole Cline (Goldberg Group Architects)	<b>From</b>	Kaleb Anderson (Hausmann Construction, Inc.) 2106 Taylor Ave, Suite 400 Norfolk, Nebraska 68701
<b>Date Initiated</b>	Jan 10, 2024	<b>Due Date</b>	Jan 17, 2024
<b>Location</b>			
<b>Cost Impact</b>	TBD	<b>Schedule Impact</b>	TBD
<b>Spec Section</b>			
<b>Drawing Number</b>	A4.01	<b>Reference</b>	
<b>Linked Drawings</b>			
<b>Received From</b>			
<b>Copies To</b>	Shane Albrecht (The Baker Group), Kaleb Anderson (Hausmann Construction, Inc.), Klay Kasik (Hausmann Construction, Inc.), Kevin Rost (Goldberg Group Architects), David Tobar (Hausmann Construction, Inc.)		
<b>BIM Related</b>	No		

### Activity

#### Question

**Question from Kaleb Anderson Hausmann Construction, Inc. on Wednesday, Jan 10, 2024 at 02:37 PM CST**

Following installation in accordance with RFI 362 response, during an onsite site-walk with GGA, it was decided that Hausmann was to move the frame inward in alignment with the CIP wall and add flashing to cover the air gap between block and wall. Please confirm this is acceptable. Please clarify what color of flashing to use.

[Yes, this is acceptable. Please provide requested photos and samples for color selection.](#)

C. Cline  
GGA  
01.15.2024

**Certificate Of Completion**

Envelope Id: 7909172690F34E838C2DB7299A6A4D4F	Status: Sent
Subject: 21-068 Woodbury - #PCO 121 - RFI 555 - FOR APRPOVAL	
Source Envelope:	
Document Pages: 4	Signatures: 1
Certificate Pages: 5	Initials: 0
AutoNav: Enabled	Envelope Originator:
Enveloped Stamping: Enabled	Amy Ahlers
Time Zone: (UTC-06:00) Central Time (US & Canada)	8885 Executive Woods Drive
	Lincoln, NE 68512
	amy@hausmannconstruction.com
	IP Address: 34.225.141.179

**Record Tracking**

Status: Original	Holder: Amy Ahlers	Location: DocuSign
1/19/2024 2:40:45 PM	amy@hausmannconstruction.com	

**Signer Events**

Klay Kasik  
 klayk@hausmannconstruction.com  
 Sr. Project Manager  
 Hausmann Construction  
 Security Level: Email, Account Authentication (None)

**Signature**

DocuSigned by:  
  
 B96656CE885642A...  
 Signature Adoption: Pre-selected Style  
 Using IP Address: 209.50.13.227

**Timestamp**

Sent: 1/19/2024 2:43:15 PM  
 Viewed: 1/19/2024 2:44:02 PM  
 Signed: 1/19/2024 2:44:56 PM

**Electronic Record and Signature Disclosure:**  
 Not Offered via DocuSign

Kevin Rost  
 kevin.r@gga.llc  
 Security Level: Email, Account Authentication (None)

Sent: 1/19/2024 2:44:57 PM  
 Viewed: 1/19/2024 3:48:08 PM

**Electronic Record and Signature Disclosure:**  
 Accepted: 5/30/2023 11:10:56 AM  
 ID: 5b5978e2-1b2f-49e4-8628-3218a723a521

Ron Wieck  
 rcwieck65@gmail.com  
 Security Level: Email, Account Authentication (None)

**Electronic Record and Signature Disclosure:**  
 Accepted: 12/6/2022 6:20:49 PM  
 ID: cb840872-8216-42eb-9ac6-0ad45abc3082

In Person Signer Events	Signature	Timestamp
-------------------------	-----------	-----------

Editor Delivery Events	Status	Timestamp
------------------------	--------	-----------

Agent Delivery Events	Status	Timestamp
-----------------------	--------	-----------

Intermediary Delivery Events	Status	Timestamp
------------------------------	--------	-----------

Certified Delivery Events	Status	Timestamp
---------------------------	--------	-----------

Carbon Copy Events	Status	Timestamp
--------------------	--------	-----------

Shane Albrecht  
 albrechts@thebakergroup.com  
 Security Level: Email, Account Authentication (None)

**COPIED**

Sent: 1/19/2024 2:44:57 PM

**Electronic Record and Signature Disclosure:**

Carbon Copy Events	Status	Timestamp
--------------------	--------	-----------

Not Offered via DocuSign

Todd Wieck  
wieckt@TheBakerGroup.com  
Security Level: Email, Account Authentication  
(None)

**COPIED**

Sent: 1/19/2024 2:44:58 PM  
Viewed: 1/24/2024 9:23:47 PM

**Electronic Record and Signature Disclosure:**  
Not Offered via DocuSign

Shane Albrecht  
albrechts@thebakergroup.com  
Security Level: Email, Account Authentication  
(None)

**Electronic Record and Signature Disclosure:**  
Not Offered via DocuSign

Todd Wieck  
wieckt@TheBakerGroup.com  
Security Level: Email, Account Authentication  
(None)

**Electronic Record and Signature Disclosure:**  
Not Offered via DocuSign

Witness Events	Signature	Timestamp
----------------	-----------	-----------

Notary Events	Signature	Timestamp
---------------	-----------	-----------

Envelope Summary Events	Status	Timestamps
-------------------------	--------	------------

Envelope Sent	Hashed/Encrypted	1/19/2024 2:43:16 PM
---------------	------------------	----------------------

Payment Events	Status	Timestamps
----------------	--------	------------

Electronic Record and Signature Disclosure
--

## **ELECTRONIC RECORD AND SIGNATURE DISCLOSURE**

From time to time, Hausmann Construction, Inc. (we, us or Company) may be required by law to provide to you certain written notices or disclosures. Described below are the terms and conditions for providing to you such notices and disclosures electronically through the DocuSign system. Please read the information below carefully and thoroughly, and if you can access this information electronically to your satisfaction and agree to this Electronic Record and Signature Disclosure (ERSD), please confirm your agreement by selecting the check-box next to 'I agree to use electronic records and signatures' before clicking 'CONTINUE' within the DocuSign system.

### **Getting paper copies**

At any time, you may request from us a paper copy of any record provided or made available electronically to you by us. You will have the ability to download and print documents we send to you through the DocuSign system during and immediately after the signing session and, if you elect to create a DocuSign account, you may access the documents for a limited period of time (usually 30 days) after such documents are first sent to you. After such time, if you wish for us to send you paper copies of any such documents from our office to you, you will be charged a \$0.00 per-page fee. You may request delivery of such paper copies from us by following the procedure described below.

### **Withdrawing your consent**

If you decide to receive notices and disclosures from us electronically, you may at any time change your mind and tell us that thereafter you want to receive required notices and disclosures only in paper format. How you must inform us of your decision to receive future notices and disclosure in paper format and withdraw your consent to receive notices and disclosures electronically is described below.

### **Consequences of changing your mind**

If you elect to receive required notices and disclosures only in paper format, it will slow the speed at which we can complete certain steps in transactions with you and delivering services to you because we will need first to send the required notices or disclosures to you in paper format, and then wait until we receive back from you your acknowledgment of your receipt of such paper notices or disclosures. Further, you will no longer be able to use the DocuSign system to receive required notices and consents electronically from us or to sign electronically documents from us.

### **All notices and disclosures will be sent to you electronically**

Unless you tell us otherwise in accordance with the procedures described herein, we will provide electronically to you through the DocuSign system all required notices, disclosures, authorizations, acknowledgements, and other documents that are required to be provided or made available to you during the course of our relationship with you. To reduce the chance of you inadvertently not receiving any notice or disclosure, we prefer to provide all of the required notices and disclosures to you by the same method and to the same address that you have given us. Thus, you can receive all the disclosures and notices electronically or in paper format through the paper mail delivery system. If you do not agree with this process, please let us know as described below. Please also see the paragraph immediately above that describes the consequences of your electing not to receive delivery of the notices and disclosures electronically from us.

### **How to contact Hausmann Construction, Inc.:**

You may contact us to let us know of your changes as to how we may contact you electronically, to request paper copies of certain information from us, and to withdraw your prior consent to receive notices and disclosures electronically as follows:

To contact us by email send messages to: [nateg@hausmannconstruction.com](mailto:nateg@hausmannconstruction.com)

### **To advise Hausmann Construction, Inc. of your new email address**

To let us know of a change in your email address where we should send notices and disclosures electronically to you, you must send an email message to us at [nateg@hausmannconstruction.com](mailto:nateg@hausmannconstruction.com) and in the body of such request you must state: your previous email address, your new email address. We do not require any other information from you to change your email address.

If you created a DocuSign account, you may update it with your new email address through your account preferences.

### **To request paper copies from Hausmann Construction, Inc.**

To request delivery from us of paper copies of the notices and disclosures previously provided by us to you electronically, you must send us an email to [nateg@hausmannconstruction.com](mailto:nateg@hausmannconstruction.com) and in the body of such request you must state your email address, full name, mailing address, and telephone number. We will bill you for any fees at that time, if any.

### **To withdraw your consent with Hausmann Construction, Inc.**

To inform us that you no longer wish to receive future notices and disclosures in electronic format you may:



i. decline to sign a document from within your signing session, and on the subsequent page, select the check-box indicating you wish to withdraw your consent, or you may;

ii. send us an email to [nateg@hausmannconstruction.com](mailto:nateg@hausmannconstruction.com) and in the body of such request you must state your email, full name, mailing address, and telephone number. We do not need any other information from you to withdraw consent.. The consequences of your withdrawing consent for online documents will be that transactions may take a longer time to process..

### **Required hardware and software**

The minimum system requirements for using the DocuSign system may change over time. The current system requirements are found here: <https://support.docusign.com/guides/signer-guide-signing-system-requirements>.

### **Acknowledging your access and consent to receive and sign documents electronically**

To confirm to us that you can access this information electronically, which will be similar to other electronic notices and disclosures that we will provide to you, please confirm that you have read this ERSD, and (i) that you are able to print on paper or electronically save this ERSD for your future reference and access; or (ii) that you are able to email this ERSD to an email address where you will be able to print on paper or save it for your future reference and access. Further, if you consent to receiving notices and disclosures exclusively in electronic format as described herein, then select the check-box next to ‘I agree to use electronic records and signatures’ before clicking ‘CONTINUE’ within the DocuSign system.

By selecting the check-box next to ‘I agree to use electronic records and signatures’, you confirm that:

- You can access and read this Electronic Record and Signature Disclosure; and
- You can print on paper this Electronic Record and Signature Disclosure, or save or send this Electronic Record and Disclosure to a location where you can print it, for future reference and access; and
- Until or unless you notify Hausmann Construction, Inc. as described above, you consent to receive exclusively through electronic means all notices, disclosures, authorizations, acknowledgements, and other documents that are required to be provided or made available to you by Hausmann Construction, Inc. during the course of your relationship with Hausmann Construction, Inc..

**PCO #122R**

Hausmann Construction, Inc.  
2106 Taylor Ave, Suite 400  
Norfolk, Nebraska 68701  
Phone: (402) 371-8650

**Project:** 21-068 - Woodbury County - Law Enforcement Center  
3701 28th St  
Sioux City, Iowa 51104

## Prime Contract Potential Change Order #122R: CE #122R - Owner Directed added signs

<b>TO:</b>	Woodbury County Law Enforcement 620 Douglas Street Sioux City, Iowa 51105	<b>FROM:</b>	Hausmann Construction, Inc. 8885 Executive Woods Drive Lincoln, Nebraska 68512
<b>PCO NUMBER/REVISION:</b>	122R / 0	<b>CONTRACT:</b>	21-068 - Woodbury County - Law Enforcement Center
<b>REQUEST RECEIVED FROM:</b>		<b>CREATED BY:</b>	Klay Kasik (Hausmann Construction, Inc.)
<b>STATUS:</b>	Pending - In Review	<b>CREATED DATE:</b>	1/31/2024
<b>REFERENCE:</b>		<b>PRIME CONTRACT CHANGE ORDER:</b>	None
<b>FIELD CHANGE:</b>	No		
<b>LOCATION:</b>		<b>ACCOUNTING METHOD:</b>	Amount Based
<b>SCHEDULE IMPACT:</b>		<b>PAID IN FULL:</b>	No
<b>EXECUTED:</b>	No	<b>SIGNED CHANGE ORDER RECEIVED DATE:</b>	
		<b>TOTAL AMOUNT:</b>	\$849.00

**POTENTIAL CHANGE ORDER TITLE:** CE #122R - Owner Directed added signs

**CHANGE REASON:** Allowance

**POTENTIAL CHANGE ORDER DESCRIPTION:** *(The Contract Is Changed As Follows)*

CE #122R - Owner Directed added signs- RFI 559

PCO 122 is created to incorporate the costs associated with RFI 559 as itemized within. Approval was requested no later than 1/26/244. Also please note that we are not waiving our right to include costs for General Conditions due to concurrent changes that are concurrently being priced. In the event that other change orders are not approved in their entirety (PR 35R & PR 38) this PCO will be subjected to additional general conditions. Please note that this is assumed to not prevent any punch list walks to occur in the location of installation.

**ATTACHMENTS:**

[21-068 -CO BACK UP 1.23.24.pdf](#) , [\\_Woodbury Co Jail vinyl change.pdf](#) , [\\_21-068-Woodbury County-Law Enforcement Center-559-Owner\\_Requested\\_Additional\\_Signs-2024-01-22.pdf](#) , [\\_Additional vinyl letters\[1\].pdf](#)

#	Description	Amount
1	Signs	\$800.00
2	Fees	\$40.00
3	Bond & Insurance	\$9.00
<b>Grand Total:</b>		<b>\$849.00</b>

**Kevin Rost (Goldberg Group Architects)**  
520 Francis Street Suite 200C  
St. Joseph, Missouri 64501

**Woodbury County Law Enforcement**  
620 Douglas Street  
Sioux City, Iowa 51105

**Hausmann Construction, Inc.**  
8885 Executive Woods Drive  
Lincoln, Nebraska 68512

SIGNATURE

DATE

SIGNATURE

DATE

DocuSigned by:

Steve Thiele

1/31/2024

380334A8122A46C...

SIGNATURE

DATE

Hausmann Construction, Inc.

Page 1 of 1

DS

KK

Printed On: 1/31/2024 03:54 PM

			<p align="center"><b>Woodbury LEC</b></p> <p align="center">RFI 559 Signs</p>				Cost Item: RFI 559 Signs 21-068      DATE: 01/31/24				
ITEM DESCRIPTION	QUANTITY	UNIT	MATERIAL COST		LABOR COSTS		EQUIPMENT COSTS		SUBCONTRACTOR		SUBTOTALS
			Rate	TOTAL	RATE	TOTAL	Rate	TOTAL	Rate	TOTAL	
<b>Self Perform</b>											
#		hours				\$ -					\$ -
		lsum				\$ -					\$ -
		hours				\$ -					\$ -
<b>Subcontracts</b>											
ACE Signs	1	1	lsum	\$ -		\$ -		\$ -	\$ 800.00	\$ 800.00	\$ 800.00
	1		lsum	\$ -		\$ -		\$ -		\$ -	\$ -
	1		lsum	\$ -		\$ -		\$ -		\$ -	\$ -
			Subtotals	\$ -		\$ -		\$ -		\$ 800.00	\$ 800.00
<b>Subtotal</b>				\$ 800.00							
<b>Self-Perform Fee</b>			10.0%	\$ -							
<b>Sub Fee</b>			5.0%	\$ 40.00							
<b>Bond &amp; Insurance</b>			1.0%	\$ 9.00							
<b>Grand Total</b>				\$ 849.00							



PHONE: 402-494-4555 FAX: 402-494-1490  
LOCATED AT: 924 B STREET SOUTH SIOUX CITY, NE 68776  
MAILING ADDRESS: P.O. BOX 1593 SIOUX CITY, IA 51102

**QUOTATION**

Woodbury County Law Enforcement Center

To: \_\_\_\_\_

Street: \_\_\_\_\_

Sioux City

IA

51106

City: \_\_\_\_\_ State: \_\_\_\_\_ Zip: \_\_\_\_\_

**Additional Vinyl room letters:**

We propose to manufacture and install 5" vinyl letters per additional list dated 1/19/24. These will replace previous vinyl letters printed but not installed.

The cost to complete this additional sign project is \$800.00.

Permits: Not Included Taxes: Not Included Delivery: 1 Week

**ADEQUATE PRIMARY ELECTRICAL SERVICE TO DISPLAY BY CUSTOMER**

Due to supply chain disruptions and market volatility, this quote is subject to repricing every 5 days. It is considered an order once downpayment is received - if after 5 days, price will be revised if needed.

**CREDIT TERMS:** 50% Down Payment at the acceptance of quotation, after which work will proceed. Balance due - net 10 days. 1-1/2% per month service charge over 30 days from completion date.

Co. Rep: Brod Pittenger

Date: 1/30/24

By: **ACE SIGN DISPLAYS**

**ACCEPTANCE**

You are hereby authorized to furnish the materials and labor necessary to complete the above work, for which (company name): \_\_\_\_\_ agrees to pay according to the above mentioned proposal.

Signed: \_\_\_\_\_ Date: \_\_\_\_\_

# Additional vinyl lettering 1/19/2024

REC 1	MED 4	5"
REC 1	MED 5	
REC 2	MED 6	
REC 2	PAD 1	
ASAP	PAD 1	
TEMP 1	PAD 2	
TEMP 2	PAD 2	
TEMP 3	PAD 3	
TEMP 4	PAD 3	
TEMP 5	INTAKE 1	
TEMP 6	INTAKE 1	
TEMP 7	INTAKE 2	
TEMP 8	INTAKE 2	
TEMP 9	INTAKE 3	
MED 1	INTAKE 3	
MED 2		
MED 3		



Hausmann Construction, Inc.  
2106 Taylor Ave, Suite 400  
Norfolk, Nebraska 68701  
P: (402) 371-8650

Project: 21-068 Woodbury County - Law  
Enforcement Center  
3701 28th St  
Sioux City, Iowa 51104

## RFI #559: Owner Requested Additional Signs

<b>Status</b>	Open		
<b>To</b>	Shane Albrecht (The Baker Group) Kevin Rost (Goldberg Group Architects) Carole Cline (Goldberg Group Architects)	<b>From</b>	Klay Kasik (Hausmann Construction, Inc.) 2106 Taylor Ave, Suite 400 Norfolk, Nebraska 68701
<b>Date Initiated</b>	Jan 22, 2024	<b>Due Date</b>	Jan 29, 2024
<b>Location</b>			
<b>Cost Impact</b>	Yes (Unknown)	<b>Schedule Impact</b>	Yes (Unknown)
<b>Spec Section</b>			
<b>Drawing Number</b>	<b>Reference</b>		
<b>Linked Drawings</b>			
<b>Received From</b>	Brad Pittenger (Ace Sign Displays Inc.)		
<b>Copies To</b>	Shane Albrecht (The Baker Group), Kaleb Anderson (Hausmann Construction, Inc.), Klay Kasik (Hausmann Construction, Inc.), Kevin Rost (Goldberg Group Architects), David Tobar (Hausmann Construction, Inc.)		
<b>BIM Related</b>	No		

### Activity

#### Question

**Question from Klay Kasik Hausmann Construction, Inc. on Monday, Jan 22, 2024 at 02:19 PM CST**

As requested from owner, please confirm that the Construction team is to furnish and add additional vinyl lettering signs. Please reference attached list.

**Attachments**

[Additional vinyl letters.pdf](#)

*Awaiting an Official Response*

**Certificate Of Completion**

Envelope Id: 74FE0AA4F5C34285843D77C0B6AC8395	Status: Sent
Subject: 21-068 Woodbury - PCO #122R - Owner Directed added signs - FOR APPROVAL	
Source Envelope:	
Document Pages: 5	Signatures: 1
Certificate Pages: 5	Initials: 1
AutoNav: Enabled	Envelope Originator:
Envelope Stamping: Enabled	Amy Ahlers
Time Zone: (UTC-06:00) Central Time (US & Canada)	8885 Executive Woods Drive
	Lincoln, NE 68512
	amy@hausmannconstruction.com
	IP Address: 54.146.192.81

**Record Tracking**

Status: Original	Holder: Amy Ahlers	Location: DocuSign
1/31/2024 3:54:59 PM	amy@hausmannconstruction.com	

**Signer Events**

Signer Events	Signature	Timestamp
Klay Kasik klayk@hausmannconstruction.com Sr. Project Manager Hausmann Construction Security Level: Email, Account Authentication (None)	 Signature Adoption: Pre-selected Style Using IP Address: 209.50.13.227 Signed using mobile	Sent: 1/31/2024 3:59:46 PM Viewed: 1/31/2024 3:59:56 PM Signed: 1/31/2024 4:00:10 PM

**Electronic Record and Signature Disclosure:**  
Not Offered via DocuSign

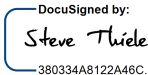
Steve Thiele stevet@hausmannconstruction.com Vice President Hausmann Construction, Inc. Security Level: Email, Account Authentication (None)	 Signature Adoption: Pre-selected Style Using IP Address: 70.37.212.90 Signed using mobile	Sent: 1/31/2024 4:00:12 PM Viewed: 1/31/2024 9:45:25 PM Signed: 1/31/2024 9:45:40 PM
--	---	--

**Electronic Record and Signature Disclosure:**  
Not Offered via DocuSign

Kevin Rost kevin.r@gga.llc Security Level: Email, Account Authentication (None)	Sent: 1/31/2024 9:45:42 PM Viewed: 2/1/2024 1:58:47 PM
---	---

**Electronic Record and Signature Disclosure:**  
Accepted: 2/1/2024 1:58:47 PM  
ID: e5dafd7c-4450-4373-a27c-727778ee91b7

Ron Wieck  
rwieck65@gmail.com  
Security Level: Email, Account Authentication (None)

**Electronic Record and Signature Disclosure:**  
Accepted: 12/6/2022 6:20:49 PM  
ID: cb840872-8216-42eb-9ac6-0ad45abc3082

In Person Signer Events	Signature	Timestamp
Editor Delivery Events	Status	Timestamp
Agent Delivery Events	Status	Timestamp
Intermediary Delivery Events	Status	Timestamp

Certified Delivery Events	Status	Timestamp
<b>Carbon Copy Events</b> Shane Albrecht albrechts@thebakergroup.com Security Level: Email, Account Authentication (None) <b>Electronic Record and Signature Disclosure:</b> Not Offered via DocuSign	<div style="border: 2px solid blue; padding: 5px; font-weight: bold; color: blue; font-size: 1.2em;">COPIED</div>	Sent: 1/31/2024 9:45:42 PM
Todd Wieck wieckt@TheBakerGroup.com Security Level: Email, Account Authentication (None) <b>Electronic Record and Signature Disclosure:</b> Not Offered via DocuSign	<div style="border: 2px solid blue; padding: 5px; font-weight: bold; color: blue; font-size: 1.2em;">COPIED</div>	Sent: 1/31/2024 9:45:43 PM Viewed: 2/5/2024 3:01:50 PM
Shane Albrecht albrechts@thebakergroup.com Security Level: Email, Account Authentication (None) <b>Electronic Record and Signature Disclosure:</b> Not Offered via DocuSign		
Todd Wieck wieckt@TheBakerGroup.com Security Level: Email, Account Authentication (None) <b>Electronic Record and Signature Disclosure:</b> Not Offered via DocuSign		
Witness Events	Signature	Timestamp
Notary Events	Signature	Timestamp
Envelope Summary Events	Status	Timestamps
Envelope Sent	Hashed/Encrypted	1/31/2024 3:59:47 PM
Payment Events	Status	Timestamps
Electronic Record and Signature Disclosure		



## **ELECTRONIC RECORD AND SIGNATURE DISCLOSURE**

From time to time, Hausmann Construction, Inc. (we, us or Company) may be required by law to provide to you certain written notices or disclosures. Described below are the terms and conditions for providing to you such notices and disclosures electronically through the DocuSign system. Please read the information below carefully and thoroughly, and if you can access this information electronically to your satisfaction and agree to this Electronic Record and Signature Disclosure (ERSD), please confirm your agreement by selecting the check-box next to 'I agree to use electronic records and signatures' before clicking 'CONTINUE' within the DocuSign system.

### **Getting paper copies**

At any time, you may request from us a paper copy of any record provided or made available electronically to you by us. You will have the ability to download and print documents we send to you through the DocuSign system during and immediately after the signing session and, if you elect to create a DocuSign account, you may access the documents for a limited period of time (usually 30 days) after such documents are first sent to you. After such time, if you wish for us to send you paper copies of any such documents from our office to you, you will be charged a \$0.00 per-page fee. You may request delivery of such paper copies from us by following the procedure described below.

### **Withdrawing your consent**

If you decide to receive notices and disclosures from us electronically, you may at any time change your mind and tell us that thereafter you want to receive required notices and disclosures only in paper format. How you must inform us of your decision to receive future notices and disclosure in paper format and withdraw your consent to receive notices and disclosures electronically is described below.

### **Consequences of changing your mind**

If you elect to receive required notices and disclosures only in paper format, it will slow the speed at which we can complete certain steps in transactions with you and delivering services to you because we will need first to send the required notices or disclosures to you in paper format, and then wait until we receive back from you your acknowledgment of your receipt of such paper notices or disclosures. Further, you will no longer be able to use the DocuSign system to receive required notices and consents electronically from us or to sign electronically documents from us.

### **All notices and disclosures will be sent to you electronically**

Unless you tell us otherwise in accordance with the procedures described herein, we will provide electronically to you through the DocuSign system all required notices, disclosures, authorizations, acknowledgements, and other documents that are required to be provided or made available to you during the course of our relationship with you. To reduce the chance of you inadvertently not receiving any notice or disclosure, we prefer to provide all of the required notices and disclosures to you by the same method and to the same address that you have given us. Thus, you can receive all the disclosures and notices electronically or in paper format through the paper mail delivery system. If you do not agree with this process, please let us know as described below. Please also see the paragraph immediately above that describes the consequences of your electing not to receive delivery of the notices and disclosures electronically from us.

### **How to contact Hausmann Construction, Inc.:**

You may contact us to let us know of your changes as to how we may contact you electronically, to request paper copies of certain information from us, and to withdraw your prior consent to receive notices and disclosures electronically as follows:

To contact us by email send messages to: [nateg@hausmannconstruction.com](mailto:nateg@hausmannconstruction.com)

### **To advise Hausmann Construction, Inc. of your new email address**

To let us know of a change in your email address where we should send notices and disclosures electronically to you, you must send an email message to us at [nateg@hausmannconstruction.com](mailto:nateg@hausmannconstruction.com) and in the body of such request you must state: your previous email address, your new email address. We do not require any other information from you to change your email address.

If you created a DocuSign account, you may update it with your new email address through your account preferences.

### **To request paper copies from Hausmann Construction, Inc.**

To request delivery from us of paper copies of the notices and disclosures previously provided by us to you electronically, you must send us an email to [nateg@hausmannconstruction.com](mailto:nateg@hausmannconstruction.com) and in the body of such request you must state your email address, full name, mailing address, and telephone number. We will bill you for any fees at that time, if any.

### **To withdraw your consent with Hausmann Construction, Inc.**

To inform us that you no longer wish to receive future notices and disclosures in electronic format you may:

i. decline to sign a document from within your signing session, and on the subsequent page, select the check-box indicating you wish to withdraw your consent, or you may;

ii. send us an email to [nateg@hausmannconstruction.com](mailto:nateg@hausmannconstruction.com) and in the body of such request you must state your email, full name, mailing address, and telephone number. We do not need any other information from you to withdraw consent.. The consequences of your withdrawing consent for online documents will be that transactions may take a longer time to process..

### **Required hardware and software**

The minimum system requirements for using the DocuSign system may change over time. The current system requirements are found here: <https://support.docusign.com/guides/signer-guide-signing-system-requirements>.

### **Acknowledging your access and consent to receive and sign documents electronically**

To confirm to us that you can access this information electronically, which will be similar to other electronic notices and disclosures that we will provide to you, please confirm that you have read this ERSD, and (i) that you are able to print on paper or electronically save this ERSD for your future reference and access; or (ii) that you are able to email this ERSD to an email address where you will be able to print on paper or save it for your future reference and access. Further, if you consent to receiving notices and disclosures exclusively in electronic format as described herein, then select the check-box next to ‘I agree to use electronic records and signatures’ before clicking ‘CONTINUE’ within the DocuSign system.

By selecting the check-box next to ‘I agree to use electronic records and signatures’, you confirm that:

- You can access and read this Electronic Record and Signature Disclosure; and
- You can print on paper this Electronic Record and Signature Disclosure, or save or send this Electronic Record and Disclosure to a location where you can print it, for future reference and access; and
- Until or unless you notify Hausmann Construction, Inc. as described above, you consent to receive exclusively through electronic means all notices, disclosures, authorizations, acknowledgements, and other documents that are required to be provided or made available to you by Hausmann Construction, Inc. during the course of your relationship with Hausmann Construction, Inc..

**PCCO #023**

Hausmann Construction, Inc.  
2106 Taylor Ave, Suite 400  
Norfolk, Nebraska 68701  
Phone: (402) 371-8650

Project: 21-068 - Woodbury County - Law Enforcement Center  
3701 28th St  
Sioux City, Iowa 51104

## Prime Contract Change Order #023: PCCO 023

<b>TO:</b>	<b>Woodbury County Law Enforcement</b> 620 Douglas Street Sioux City, Iowa 51105	<b>FROM:</b>	<b>Hausmann Construction, Inc.</b> 8885 Executive Woods Drive Lincoln, Nebraska 68512
<b>DATE CREATED:</b>	2/06/2024	<b>CREATED BY:</b>	Amy Ahlers (Hausmann Construction, Inc.)
<b>CONTRACT STATUS:</b>	Pending - In Review	<b>REVISION:</b>	0
<b>DESIGNATED REVIEWER:</b>		<b>REVIEWED BY:</b>	
<b>DUE DATE:</b>		<b>REVIEW DATE:</b>	
<b>INVOICED DATE:</b>		<b>PAID DATE:</b>	
<b>SCHEDULE IMPACT:</b>		<b>EXECUTED:</b>	No
<b>REVISED SUBSTANTIAL COMPLETION DATE:</b>		<b>SIGNED CHANGE ORDER RECEIVED DATE:</b>	
<b>CONTRACT FOR:</b>	21-068:Woodbury County - Law Enforcement Center	<b>TOTAL AMOUNT:</b>	\$30,286.00

**DESCRIPTION:**

PCCO 022 is being submitted to process PCOs 086R2, 109R3, 121 and 122R as itemized within. Please note that our new substantial completion date is proposed for May 23rd, 2024. as identified within PCO 114 (CCD #9), and we are reserving our right to claim additional concurrent costs in the event that PCO 081 & 114 is not approved as currently submitted for time and cost.

**ATTACHMENTS:****POTENTIAL CHANGE ORDERS IN THIS CHANGE ORDER:**

PCO #	Title	Schedule Impact	Amount
086R2	CE #PCO 086R2 - PR 36R - Elec		\$28,916.00
109R3	CE #PCO 109 R3 - RFI #519 - Fire ceilings		(\$1,578.00)
121	CE #PCO 121 - RFI 555		\$2,099.00
122R	CE #122R - Owner Directed added signs		\$849.00
<b>Total:</b>			<b>\$30,286.00</b>

**CHANGE ORDER LINE ITEMS:****PCO # 086R2: CE #PCO 086R2 - PR 36R - Elec**

#	Description	Amount
1	Thompson	\$20,925.00
2	Tri-State	\$745.00
3	Kucera	\$3,190.00
4	Hausmann	\$2,296.00
5	Fees	\$1,473.00
6	Bond & Insurance	\$287.00
<b>Grand Total:</b>		<b>\$28,916.00</b>

**PCO # 109R3: CE #PCO 109 R3 - RFI #519 - Fire ceilings**

#	Description	Amount
1	Ramirez	\$15,320.00



**PCCO #023**

#	Description	Amount
2	Pauly Jail	\$848.00
3	Tri-State	\$2,345.00
4	Suter	\$539.00
5	Thompson	\$1,460.00
6	WRC	\$2,600.00
7	Kucera	\$1,650.00
8	Framing Material	\$2,000.00
9	Masonry	\$(13,011.00)
10	Rebar	\$(4,325.00)
11		\$(10,973.00)
12	Fees	\$(31.00)
<b>Grand Total:</b>		<b>\$(1,578.00)</b>

**PCO # 121: CE #PCO 121 - RFI 555**

#	Description	Amount
1	Hausmann	\$752.00
2	Blankenship	\$1,190.00
3	Fees	\$136.00
4	Bond & Insurance	\$21.00
<b>Grand Total:</b>		<b>\$2,099.00</b>

**PCO # 122R: CE #122R - Owner Directed added signs**

#	Description	Amount
1	Signs	\$800.00
2	Fees	\$40.00
3	Bond & Insurance	\$9.00
<b>Grand Total:</b>		<b>\$849.00</b>

The original (Contract Sum)	\$58,390,000.00
Net change by previously authorized Change Orders	\$2,355,034.00
The contract sum prior to this Change Order was	\$60,745,034.00
The contract sum would be changed by this Change Order in the amount of	\$30,286.00
The new contract sum including this Change Order will be	\$60,775,320.00
The contract time will not be changed by this Change Order.	

**Kevin Rost (Goldberg Group Architects)**  
 520 Francis Street Suite 200C  
 St. Joseph, Missouri 64501

**Woodbury County Law Enforcement**  
 620 Douglas Street  
 Sioux City, Iowa 51105

**Hausmann Construction, Inc.**  
 8885 Executive Woods Drive  
 Lincoln, Nebraska 68512

\_\_\_\_\_  
 SIGNATURE DATE

\_\_\_\_\_  
 SIGNATURE DATE

DocuSigned by:  
  
 2/7/2024  
380324A8122A46C...  
 \_\_\_\_\_  
 SIGNATURE DATE

**Certificate Of Completion**

Envelope Id: 55C8B1D2A0194EFAA439D76BEEE20DAC  
 Subject: 21-068 Woodbury - PCCO 023 -FOR APPROVAL  
 Source Envelope:  
 Document Pages: 2 Signatures: 1  
 Certificate Pages: 5 Initials: 1  
 AutoNav: Enabled  
 Envelope Stamping: Enabled  
 Time Zone: (UTC-06:00) Central Time (US & Canada)

Status: Sent  
 Envelope Originator:  
 Amy Ahlers  
 8885 Executive Woods Drive  
 Lincoln, NE 68512  
 amya@hausmannconstruction.com  
 IP Address: 54.146.192.81

**Record Tracking**

Status: Original Holder: Amy Ahlers Location: DocuSign  
 2/7/2024 4:05:39 PM amya@hausmannconstruction.com

**Signer Events**

Klay Kasik  
 klayk@hausmannconstruction.com  
 Sr. Project Manager  
 Hausmann Construction  
 Security Level: Email, Account Authentication (None)

**Signature**

  
 Signature Adoption: Pre-selected Style  
 Using IP Address: 174.228.35.101  
 Signed using mobile

**Timestamp**

Sent: 2/7/2024 4:10:28 PM  
 Viewed: 2/7/2024 5:34:10 PM  
 Signed: 2/7/2024 5:34:37 PM

**Electronic Record and Signature Disclosure:**  
 Not Offered via DocuSign

Steve Thiele  
 stevet@hausmannconstruction.com  
 Vice President  
 Hausmann Construction, Inc.  
 Security Level: Email, Account Authentication (None)

  
 Signature Adoption: Pre-selected Style  
 Using IP Address: 70.37.212.90  
 Signed using mobile

Sent: 2/7/2024 5:34:38 PM  
 Viewed: 2/7/2024 10:26:55 PM  
 Signed: 2/7/2024 10:27:08 PM

**Electronic Record and Signature Disclosure:**  
 Not Offered via DocuSign

Kevin Rost  
 kevin.r@gga.llc  
 Security Level: Email, Account Authentication (None)

Sent: 2/7/2024 10:27:09 PM

**Electronic Record and Signature Disclosure:**  
 Accepted: 2/1/2024 1:58:47 PM  
 ID: e5dafd7c-4450-4373-a27c-727778ee91b7

Ron Wieck  
 rcwieck65@gmail.com  
 Security Level: Email, Account Authentication (None)

**Electronic Record and Signature Disclosure:**  
 Accepted: 12/6/2022 6:20:49 PM  
 ID: cb840872-8216-42eb-9ac6-0ad45abc3082

In Person Signer Events	Signature	Timestamp
Editor Delivery Events	Status	Timestamp
Agent Delivery Events	Status	Timestamp
Intermediary Delivery Events	Status	Timestamp

Certified Delivery Events	Status	Timestamp
<b>Carbon Copy Events</b> Shane Albrecht albrechts@thebakergroup.com Security Level: Email, Account Authentication (None) <b>Electronic Record and Signature Disclosure:</b> Not Offered via DocuSign	<div style="border: 2px solid blue; padding: 5px; display: inline-block; color: blue; font-weight: bold; font-size: 1.2em;">COPIED</div>	Sent: 2/7/2024 10:27:09 PM
Todd Wieck wieckt@TheBakerGroup.com Security Level: Email, Account Authentication (None) <b>Electronic Record and Signature Disclosure:</b> Not Offered via DocuSign	<div style="border: 2px solid blue; padding: 5px; display: inline-block; color: blue; font-weight: bold; font-size: 1.2em;">COPIED</div>	Sent: 2/7/2024 10:27:10 PM Viewed: 2/8/2024 10:00:46 AM
Shane Albrecht albrechts@thebakergroup.com Security Level: Email, Account Authentication (None) <b>Electronic Record and Signature Disclosure:</b> Not Offered via DocuSign		
Todd Wieck wieckt@TheBakerGroup.com Security Level: Email, Account Authentication (None) <b>Electronic Record and Signature Disclosure:</b> Not Offered via DocuSign		
Witness Events	Signature	Timestamp
Notary Events	Signature	Timestamp
Envelope Summary Events	Status	Timestamps
Envelope Sent	Hashed/Encrypted	2/7/2024 4:10:28 PM
Payment Events	Status	Timestamps
Electronic Record and Signature Disclosure		

## **ELECTRONIC RECORD AND SIGNATURE DISCLOSURE**

From time to time, Hausmann Construction, Inc. (we, us or Company) may be required by law to provide to you certain written notices or disclosures. Described below are the terms and conditions for providing to you such notices and disclosures electronically through the DocuSign system. Please read the information below carefully and thoroughly, and if you can access this information electronically to your satisfaction and agree to this Electronic Record and Signature Disclosure (ERSD), please confirm your agreement by selecting the check-box next to 'I agree to use electronic records and signatures' before clicking 'CONTINUE' within the DocuSign system.

### **Getting paper copies**

At any time, you may request from us a paper copy of any record provided or made available electronically to you by us. You will have the ability to download and print documents we send to you through the DocuSign system during and immediately after the signing session and, if you elect to create a DocuSign account, you may access the documents for a limited period of time (usually 30 days) after such documents are first sent to you. After such time, if you wish for us to send you paper copies of any such documents from our office to you, you will be charged a \$0.00 per-page fee. You may request delivery of such paper copies from us by following the procedure described below.

### **Withdrawing your consent**

If you decide to receive notices and disclosures from us electronically, you may at any time change your mind and tell us that thereafter you want to receive required notices and disclosures only in paper format. How you must inform us of your decision to receive future notices and disclosure in paper format and withdraw your consent to receive notices and disclosures electronically is described below.

### **Consequences of changing your mind**

If you elect to receive required notices and disclosures only in paper format, it will slow the speed at which we can complete certain steps in transactions with you and delivering services to you because we will need first to send the required notices or disclosures to you in paper format, and then wait until we receive back from you your acknowledgment of your receipt of such paper notices or disclosures. Further, you will no longer be able to use the DocuSign system to receive required notices and consents electronically from us or to sign electronically documents from us.

### **All notices and disclosures will be sent to you electronically**



Unless you tell us otherwise in accordance with the procedures described herein, we will provide electronically to you through the DocuSign system all required notices, disclosures, authorizations, acknowledgements, and other documents that are required to be provided or made available to you during the course of our relationship with you. To reduce the chance of you inadvertently not receiving any notice or disclosure, we prefer to provide all of the required notices and disclosures to you by the same method and to the same address that you have given us. Thus, you can receive all the disclosures and notices electronically or in paper format through the paper mail delivery system. If you do not agree with this process, please let us know as described below. Please also see the paragraph immediately above that describes the consequences of your electing not to receive delivery of the notices and disclosures electronically from us.

**How to contact Hausmann Construction, Inc.:**

You may contact us to let us know of your changes as to how we may contact you electronically, to request paper copies of certain information from us, and to withdraw your prior consent to receive notices and disclosures electronically as follows:

To contact us by email send messages to: [nateg@hausmannconstruction.com](mailto:nateg@hausmannconstruction.com)

**To advise Hausmann Construction, Inc. of your new email address**

To let us know of a change in your email address where we should send notices and disclosures electronically to you, you must send an email message to us at [nateg@hausmannconstruction.com](mailto:nateg@hausmannconstruction.com) and in the body of such request you must state: your previous email address, your new email address. We do not require any other information from you to change your email address.

If you created a DocuSign account, you may update it with your new email address through your account preferences.

**To request paper copies from Hausmann Construction, Inc.**

To request delivery from us of paper copies of the notices and disclosures previously provided by us to you electronically, you must send us an email to [nateg@hausmannconstruction.com](mailto:nateg@hausmannconstruction.com) and in the body of such request you must state your email address, full name, mailing address, and telephone number. We will bill you for any fees at that time, if any.

**To withdraw your consent with Hausmann Construction, Inc.**

To inform us that you no longer wish to receive future notices and disclosures in electronic format you may:

i. decline to sign a document from within your signing session, and on the subsequent page, select the check-box indicating you wish to withdraw your consent, or you may;

ii. send us an email to [nateg@hausmannconstruction.com](mailto:nateg@hausmannconstruction.com) and in the body of such request you must state your email, full name, mailing address, and telephone number. We do not need any other information from you to withdraw consent.. The consequences of your withdrawing consent for online documents will be that transactions may take a longer time to process..

### **Required hardware and software**

The minimum system requirements for using the DocuSign system may change over time. The current system requirements are found here: <https://support.docusign.com/guides/signer-guide-signing-system-requirements>.

### **Acknowledging your access and consent to receive and sign documents electronically**

To confirm to us that you can access this information electronically, which will be similar to other electronic notices and disclosures that we will provide to you, please confirm that you have read this ERSD, and (i) that you are able to print on paper or electronically save this ERSD for your future reference and access; or (ii) that you are able to email this ERSD to an email address where you will be able to print on paper or save it for your future reference and access. Further, if you consent to receiving notices and disclosures exclusively in electronic format as described herein, then select the check-box next to ‘I agree to use electronic records and signatures’ before clicking ‘CONTINUE’ within the DocuSign system.

By selecting the check-box next to ‘I agree to use electronic records and signatures’, you confirm that:

- You can access and read this Electronic Record and Signature Disclosure; and
- You can print on paper this Electronic Record and Signature Disclosure, or save or send this Electronic Record and Disclosure to a location where you can print it, for future reference and access; and
- Until or unless you notify Hausmann Construction, Inc. as described above, you consent to receive exclusively through electronic means all notices, disclosures, authorizations, acknowledgements, and other documents that are required to be provided or made available to you by Hausmann Construction, Inc. during the course of your relationship with Hausmann Construction, Inc..