



NOTICE OF MEETING OF THE WOODBURY COUNTY BOARD OF SUPERVISORS
(NOVENBER 7) (WEEK 45 OF 2023)

Live streaming at:
https://www.youtube.com/user/woodburycountyiowa

Agenda and Minutes available at:
www.woodburycountyiowa.gov

Daniel A. Bittinger II
389-4405
dbittinger@woodburycountyiowa.gov

Mark Nelson
540-1259
mnelson@woodburycountyiowa.gov

Keith W. Radig
560-6542
kradig@woodburycountyiowa.gov

Jeremy Taylor
259-7910
jtaylor@woodburycountyiowa.gov

Matthew A. Ung
490-7852
matthewung@woodburycountyiowa.gov

You are hereby notified a meeting of the Woodbury County Board of Supervisors will be held November 7, 2023, at 4:30 p.m. in the Basement of the Courthouse, 620 Douglas Street, Sioux City, Iowa for the purpose of taking official action on the agenda items shown hereinafter and for such other business that may properly come before the Board.

This is a formal meeting during which the Board may take official action on various items of business. Members of the public wishing to speak on an item must follow the participation rules adopted by the Board of Supervisors.

- 1. Please silence cell phones and other devices while in the Boardroom.
2. The Chair may recognize speakers on agenda items after initial discussion by the Board.
3. Speakers will approach the microphone one at a time and give their name and address before their statement.
4. Speakers will limit their remarks to three minutes on any one item and address their remarks to the Board.
5. At the beginning of discussion on any item, the Chair may request statements in favor of an action be heard first followed by statements in opposition to the action. The Chair may also request delegates provide statements on behalf of multiple speakers.
6. Any concerns or questions which do not relate to a scheduled item on the agenda will be heard under the item "Citizen Concerns." Please note the Board is legally prohibited from taking action on or engaging in deliberation on concerns not listed on the agenda, and in such cases the Chair will request further discussion take place after properly noticed.
7. Public comment by electronic or telephonic means is prohibited except for a particular agenda item when approved by the Chair 24 hours before a meeting or by a majority of the board during a meeting for a subsequent meeting.

AGENDA

- 3:15 p.m. Closed Session with LEC Authority {Iowa Code Section 21.5 (1) (c)} - First Floor Boardroom
3:45 p.m. Closed Session {Iowa Code Section 21.5 (1) (c)} - First Floor Boardroom
4:30 p.m. Call Meeting to Order - Pledge of Allegiance to the Flag - Moment of Silence

- 1. Approval of the agenda Action
Consent Agenda

Items 2 through 5 constitute a Consent Agenda of routine action items to be considered by one motion. Items pass unanimously unless a separate vote is requested by a Board Member.

- 2. Approval of the minutes of the October 31, 2023 meeting
3. Approval of claims
4. Secondary Roads - Mark Nahra
a. Approval of permit to work in the right of way for SBT Foods/RP Constructor and to direct the chair to sign the permit

5. Human Resources – Melissa Thomas
  - a. Approval of Memorandum of Personnel Transactions
  - b. Authorization to Initiate Hiring Process
  - c. Approval for the Chairman to sign the Delta Dental 2024 Renewal

**End Consent Agenda**

- |   |                          |
|---|--------------------------|
| <ol style="list-style-type: none"> <li>6. Secondary Roads – Mark Nahra<br/>Woodbury County receives the 2023 National Lifetime Pavement Recognition Award</li> </ol>  | Information              |
| <ol style="list-style-type: none"> <li>7. Board of Supervisors – Matthew Ung &amp; County Attorney – James Loomis<br/>Discussion and potential action regarding the hiring of outside legal counsel regarding the Law Enforcement Center project</li> </ol>   | Action                   |
| <ol style="list-style-type: none"> <li>8. Board of Supervisors – Jeremy Taylor &amp; Daniel Bittinger           <ol style="list-style-type: none"> <li>a. Authorize \$1,340 from gaming revenues to highlight and support veterans and their families during the month of November</li> <li>b. Approval of resolution for veterans</li> </ol> </li> </ol> | <br>Action<br><br>Action |
| <ol style="list-style-type: none"> <li>9. Board of Supervisors – Mark Nelson<br/>Give direction to the LEC Authority on placement of meeting recordings</li> </ol>  | Action                   |
| <ol style="list-style-type: none"> <li>10. Reports on Committee Meetings</li> </ol>   | Information              |
| <ol style="list-style-type: none"> <li>11. Citizen Concerns</li> </ol>  | Information              |
| <ol style="list-style-type: none"> <li>12. Board Concerns</li> </ol>  | Information              |

**ADJOURNMENT**

*Subject to Additions/Deletions*

## CALENDAR OF EVENTS

- MON., NOV. 6**    **6:00 p.m.**    Board of Adjustment meeting, First Floor Boardroom
- WED., NOV. 8**    **7:30 a.m.**    SIMPCO – Executive-Finance Committee - Hybrid
- 8:05 a.m.**    Woodbury County Information Communication Commission, First Floor Boardroom
- 12:00 p.m.**    District Board of Health Meeting, 1014 Nebraska St.
- 6:30 p.m.**    911 Service Board Meeting, Public Safety Center, Climbing Hill
- THU., NOV. 9**    **10:00 a.m.**    SIMPCO Board of Directors, Zoom
- WED., NOV. 15** **10:00 a.m.**    StarComm, Security Institute, WIT
- 12:00 p.m.**    Siouxland Economic Development Corporation Meeting, 617 Pierce St., Ste. 202
- THU., NOV. 16** **10:00 a.m.**    Siouxland Regional Transit System, Hybrid
- 11:15 a.m.**    SIMPCO – Western Iowa Community Improvement Regional Housing Trust Fund, Hybrid
- 4:30 p.m.**    Community Action Agency of Siouxland Board Meeting, 2700 Leech Avenue
- FRI., NOV. 17** **12:00 p.m.**    Siouxland Human Investment Partnership Board Meeting, 2540 Glenn Ave.
- WED., NOV. 22** **2:30 p.m.**    Rolling Hills Community Services Region Governance Board Meeting
- THU., NOV. 23** **11:00 a.m.**    Siouxland Regional Transit Systems (SRTS) Board Meeting, SIMPCO Office, 1122 Pierce
- MON., NOV. 27** **6:00 p.m.**    Zoning Commission Meeting, First Floor Boardroom
- FRI., DEC. 1**    **8:30 a.m.**    SIMPCO Regional Policy & Legislative Affairs Committee – Tri-State Legislative Forum
- MON., DEC. 4**    **6:00 p.m.**    Board of Adjustment meeting, First Floor Boardroom
- WED., DEC. 6**    **10:00 a.m.**    Loess Hills Alliance Stewardship Committee Meeting, Pisgah, Iowa
- 11:00 a.m.**    Loess Hills Alliance Executive Meeting
- 1:00 p.m.**    Loess Hills Alliance Full Board Meeting
- 4:45 p.m.**    Veteran Affairs Meeting, Veteran Affairs Office, 1211 Tri-View Ave.
- WED., DEC. 13** **8:05 a.m.**    Woodbury County Information Communication Commission, First Floor Boardroom
- 12:00 p.m.**    District Board of Health Meeting, 1014 Nebraska St.
- THU., DEC. 14** **12:00 p.m.**    SIMPCO Board of Directors, 1122 Pierce St.
- 4:00 p.m.**    Conservation Board Meeting, Dorothy Pecaut Nature Center, Stone Park

**Woodbury County is an Equal Opportunity Employer. In compliance with the Americans with Disabilities Act, the County will consider reasonable accommodations for qualified individuals with disabilities and encourages prospective employees and incumbents to discuss potential accommodations with the Employer.**

*Federal and state laws prohibit employment and/or public accommodation discrimination on the basis of age, color, creed, disability, gender identity, national origin, pregnancy, race, religion, sex, sexual orientation or veteran's status. If you believe you have been discriminated against, please contact the Iowa Civil Rights Commission at 800-457-4416 or Iowa Department of Transportation's civil rights coordinator. If you need accommodations because of a disability to access the Iowa Department of Transportation's services, contact the agency's affirmative action officer at 800-262-0003.*

**OCTOBER 31, 2023, FORTY-FOURTH MEETING OF THE WOODBURY COUNTY BOARD OF SUPERVISORS**

The Board of Supervisors met on Tuesday, October 31, 2023, at 4:30 p.m. Board members present were Nelson, Ung, Bittinger II, Radig, and Taylor. Staff members present were Karen James, Board Administrative Assistant, Dennis Butler, Finance and Budget Director, Joshua Widman, Assistant County Attorney, Melissa Thomas, Human Resources Director, and Michelle Skaff, Deputy Auditor/Clerk to the Board.

The regular meeting was called to order with the Pledge of Allegiance to the Flag and a Moment of Silence.

1. Motion by Ung second by Taylor to approve the agenda for October 31, 2023. Carried 5-0. Copy filed.  
Motion by Ung second by Radig to approve the following items by consent:
2. To approve minutes of the October 24, 2023 meeting. Copy filed.
3. To approve the claims totaling \$696,002.48. Copy filed.
- 4a. To approve property tax refund for Lawrance Rubis, for parcel #884706377006, 2730 S Coral St., in the amount of \$322.00. Copy filed.
- 4b. To approve property tax refund for Closing Siouxland, for parcel #894729401008, 611 W 2<sup>nd</sup> St., in the amount of \$226.00. Copy filed.
- 4c. To approve property tax refund for Washington Prime Group, for parcel #884707476002, 4400 Sergeant Rd., in the amount of \$438,476.00. Copy filed.
- 4d. To approve property tax refund for Britt Capital LLC, for parcel #884333351004, 315 E Main St., Anthon, in the amount of \$1,457.00. Copy filed.
- 5a. To approve the appointment of Katrina Cox, Clerk II, County Treasurer Dept., effective 11-01-23, \$18.68/hour. Job Vacancy Posted 7-26-23. Entry Level Salary: \$18.68/hour.; and the reclassification of Jacob Gilreath, Civil Engineer Intern, Secondary Roads Dept., effective 11-13-23, \$3,010.52/bi-weekly, 5.75%=\$163.69/bi-weekly. Per Wage Plan Matrix, 6 month Salary Increase. Copy filed.
- 5b. Presentation of Award Certificate to Cynthia Wiemold. Copy filed.
6. To approve and authorize the Chairperson to sign a Resolution approving petition for suspension of taxes for Delores Sturgeon, 2362 W. 1<sup>st</sup> St., parcel #894730401004.

**WOODBURY COUNTY, IOWA  
RESOLUTION #13,676  
RESOLUTION APPROVING PETITION FOR SUSPENSION OF TAXES**

**WHEREAS**, Delores Sturgeon, as titleholder of a property located 2362 W. 1<sup>st</sup> St., Sioux City, Woodbury County, Iowa, and legally described as follows:

**Parcel #894730401004**

**HIGHLAND 1 & 2 SUB DIV LOT 2 TAX LOT B**

**WHEREAS**, Delores Sturgeon of the aforementioned property has petitioned the Board of Supervisors for a suspension of taxes pursuant to the 2017 Iowa Code section 427.9, and

**WHEREAS**, the Board of Supervisors recognizes from documents provided that the petitioner is unable to provide to the public revenue; and

**NOW, THEREFORE, BE IT RESOLVED**, that the Woodbury County Board of Supervisors hereby grants the request for a suspension of taxes, and hereby directs the Woodbury County Treasurer to so record the approval of this tax suspension for this property.

**SO RESOLVED** this 31st day of October 2023.  
WOODBURY COUNTY BOARD OF SUPERVISORS  
Copy filed.

Carried 5-0.

- 7. Motion by Radig second by Bittinger to receive the 2023 report of the weed commissioner. Carried 5-0. Copy filed.
- 8a. Motion by Taylor second by Ung to receive the final staff report and Zoning Commission’s recommendation from their 10/23/23 meeting to approve the final plat of Back Acre Estates, Second Filing, a minor subdivision to Woodbury County, Iowa. Carried 5-0. Copy filed.
- 8b. Motion by Taylor second by Radig to approve and authorize the Chairperson to sign a Resolution accepting and approving the final plat of Back Acre Estates, Second Filing, a minor subdivision to Woodbury County. Carried 5-0.

**BOARD OF SUPERVISORS  
RESOLUTION #13,677  
ACCEPTING AND APPROVING BACK ACRE ESTATES  
SECOND FILING, A MINOR SUBDIVISION  
WOODBURY COUNTY, IOWA**

WHEREAS, THE OWNERS AND PROPRIETORS DID ON THE 23<sup>RD</sup> DAY OF OCTOBER, 2023, FILE WITH THE WOODBURY COUNTY ZONING COMMISSION A CERTAIN PLAT DESIGNATED AS BACK ACRE ESTATES, SECOND FILING, WOODBURY COUNTY, IOWA; AND

WHEREAS, IT APPEARS THAT SAID PLAT CONFORMS WITH ALL OF THE PROVISIONS OF THE CODE OF THE STATE OF IOWA AND ORDINANCES OF WOODBURY COUNTY, IOWA, WITH REFERENCE TO THE FILING OF SAME; AND

WHEREAS, THE ZONING COMMISSION OF WOODBURY COUNTY, IOWA HAS RECOMMENDED THE ACCEPTANCE AND APPROVAL OF SAID PLAT; AND

WHEREAS, THE COUNTY ENGINEER OF WOODBURY COUNTY, IOWA HAS RECOMMENDED THE ACCEPTANCE AND APPROVAL OF SAID PLAT.

NOW THEREFORE, BE, AND IT IS HEREBY RESOLVED BY THE WOODBURY COUNTY BOARD OF SUPERVISORS, WOODBURY COUNTY, STATE OF IOWA, THAT THE PLAT OF BACK ACRE ESTATES, SECOND FILING, WOODBURY COUNTY, IOWA BE, AND THE SAME IS HEREBY ACCEPTED AND APPROVED, AND THE CHAIRMAN AND SECRETARY OF THE WOODBURY COUNTY BOARD OF SUPERVISORS, WOODBURY COUNTY, STATE OF IOWA, ARE HEREBY DIRECTED TO FURNISH TO THE OWNERS AND PROPRIETORS A CERTIFIED COPY OF THIS RESOLUTION AS REQUIRED BY LAW.

PASSED AND APPROVED THIS 31ST DAY OF OCTOBER, 2023.  
WOODBURY COUNTY BOARD OF SUPERVISORS  
Copy filed.

- 8c. Motion by Radig second by Ung to receive the final staff report and Zoning Commission’s recommendation from their 10/23/23 meeting to approve the final plat of Gray First Addition, a minor subdivision to Woodbury County, Iowa. Carried 5-0. Copy filed.
- 8d. Motion by Taylor second by Ung to approve and authorize the Chairperson to sign a Resolution accepting and approving the final plat of Gray First Addition, a minor subdivision to Woodbury County. Carried 5-0.

**BOARD OF SUPERVISORS  
RESOLUTION #13,678  
ACCEPTING AND APPROVING GRAY FIRST ADDITION  
A MINOR SUBDIVISION  
WOODBURY COUNTY, IOWA**

WHEREAS, THE OWNERS AND PROPRIETORS DID ON THE 23<sup>RD</sup> DAY OF OCTOBER, 2023, FILE WITH THE WOODBURY COUNTY ZONING COMMISSION A CERTAIN PLAT DESIGNATED AS "GRAY FIRST ADDITION", WOODBURY COUNTY, IOWA; AND

WHEREAS, IT APPEARS THAT SAID PLAT CONFORMS WITH ALL OF THE PROVISIONS OF THE CODE OF THE STATE OF IOWA AND ORDINANCES OF WOODBURY COUNTY, IOWA, WITH REFERENCE TO THE FILING OF SAME; AND WHEREAS THE ZONING COMMISSION OF WOODBURY COUNTY, IOWA, HAS RECOMMENDED THE ACCEPTANCE AND APPROVAL OF SAID PLAT; AND

WHEREAS THE COUNTY ENGINEER OF WOODBURY COUNTY, IOWA, HAS RECOMMENDED THE ACCEPTANCE AND APPROVAL OF SAID PLAT.

NOW, THEREFORE, BE, AND IT IS HEREBY RESOLVED BY THE WOODBURY COUNTY BOARD OF SUPERVISORS, WOODBURY COUNTY, STATE OF IOWA, THAT THE PLAT OF "GRAY FIRST ADDITION", WOODBURY COUNTY, IOWA BE, AND THE SAME IS HEREBY ACCEPTED AND APPROVED, AND THE CHAIRMAN AND SECRETARY OF THE WOODBURY COUNTY BOARD OF SUPERVISORS, WOODBURY COUNTY, STATE OF IOWA, ARE HEREBY DIRECTED TO FURNISH TO THE OWNER AND PROPRIETOR A CERTIFIED COPY OF THIS RESOLUTION AS REQUIRED BY LAW.

PASSED AND APPROVED THIS 31<sup>ST</sup> DAY OF OCTOBER, 2023  
WOODBURY COUNTY BOARD OF SUPERVISORS  
Copy filed.

- 9. Dan Bittinger II and Mark Nelson, Board of Supervisors, gave an update on legal fee expenditures to-date for open records request as approved by the Board on August 8, 2023. Copy filed.
- 10. Mark Nelson, Board of Supervisor, presented correction and information regarding statements made about Baker Group's compensation. Copy filed.  
  
Doyle Turner, Merville, addressed the board with compliments of their response to the law enforcement center project's progress.
- 11. Motion by Taylor second by Ung to postpone the hiring of outside legal counsel, and authorize the Chairperson to sign Letter of Engagement with Whitfield and Eddy Law, John A. Templar, Jr. Carried 5-0. Copy filed.  
  
Doyle Turner, Merville, addressed the board in support of hiring Mr. Templar as outside counsel.
- 12. Reports on committee meetings were heard.
- 13. There were no citizen concerns.
- 14. Board concerns were heard.

The Board adjourned the regular meeting until November 7, 2023.

Meeting sign in sheet. Copy filed.

**WOODBURY COUNTY BOARD OF SUPERVISORS AGENDA ITEM(S) REQUEST FORM**

Date: 11/2/2023 Weekly Agenda Date: 11/7/2023

**ELECTED OFFICIAL / DEPARTMENT HEAD / CITIZEN:** Mark J. Nahra, County Engineer

**WORDING FOR AGENDA ITEM:**

Consideration of permit to work in the county right of way for SBT Foods/RP Constructors

**ACTION REQUIRED:**

Approve Ordinance

Approve Resolution

Approve Motion

Public Hearing

Other: Informational

Attachments

**EXECUTIVE SUMMARY:**

RP Constructors has requested a permit to work in the right of way on behalf of SBT Foods to pump biosolids to farm fields for fertilizer.

**BACKGROUND:**

Work in county ROW requires permit by Board of Supervisors per section 318.8 of the Code of Iowa. SBT Foods has contracted with RP Constructors and area farmers to pump biosolids to farm fields for use as fertilizer. 235th Street will be closed for a maximum two days. County ditches and culverts may be occupied for varying periods by hoses moving the biosolids to the fields.

**FINANCIAL IMPACT:**

No impact

**IF THERE IS A CONTRACT INVOLVED IN THE AGENDA ITEM, HAS THE CONTRACT BEEN SUBMITTED AT LEAST ONE WEEK PRIOR AND ANSWERED WITH A REVIEW BY THE COUNTY ATTORNEY'S OFFICE?**

Yes  No

**RECOMMENDATION:**

Recommend approval of the permit for SBT Foods/RP Constructors.

**ACTION REQUIRED / PROPOSED MOTION:**

Motion to approve the permit to work in the right of way for SBT Foods/RP Constructors and to direct the chair to sign the permit.

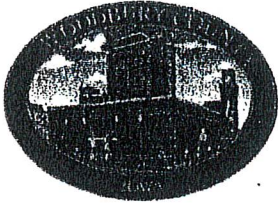

# Woodbury County Secondary Roads Department

759 E. Frontage Road • Merville, Iowa 51039  
Telephone (712) 279-6484 • (712) 873-3215 • Fax (712) 873-3235

COUNTY ENGINEER  
Mark J. Nahra, P.E.  
mnahra@woodburycountyiowa.gov

ASSISTANT TO THE COUNTY ENGINEER  
Benjamin T. Kusler, E.I.T.  
bkusler@woodburycountyiowa.gov

SECRETARY  
Tish Brice  
tbrice@woodburycountyiowa.gov

## WOODBURY COUNTY SECONDARY ROAD DEPARTMENT PERMIT & AGREEMENT TO PERFORM WORK WITHIN WOODBURY COUNTY RIGHT OF WAY

Name of Permittee: RP Constructors Phone No.: 712-222-1452

Mailing Address: 1270 S Derby Ln. , North Sioux City, SD 57049

Township: Liberty West Section: See Map

Woodbury County, State of Iowa, and RP Constructors (hereinafter referred to as property owner, organization or authorized representative) do hereby enter into the following permit and agreement:

1. Woodbury County hereby consents to and grants permission to the property owner, organization or authorized representative, to conduct the following described construction or activities within the right-of-way:

Permittee may run hoses for pumping biosolids for application through county

ditches & culverts. Affected Roads are 235th, 240th, and Allison Ave. Hoses may

be in ditches and through culverts. 235th will be closed for a maximum of two days.

2. In consideration of Woodbury County granting said permission and consent, the property owner, organization or authorized representative hereby promises and agrees to the following:

A. The applicant shall carry on the construction, repair and maintenance with serious regard to the safety of the traveling public and adjacent property owners.

B. The property owner, organization or authorized representative, at his/her own expense, shall provide all safety measures and warning devices necessary to protect the traveling public such as but not limited to, signs, lights, and barricades during the day and at night if the roadway will be obstructed. Traffic protection shall be in accordance with Part VI of the current Manual on Uniform Traffic Control Devices for Streets and Highways. The Department will loan the required signs to the applicant who shall be responsible for placing the signs and covering or removing when not in use, removal after the work has been completed, and return of the Department owned signs to the Department maintenance facility from which obtained. The applicant shall be responsible for correctly using signs as needed while work is in progress. Flagging operations are the responsibility of the applicant.

C. In placing any drainage structure, no natural drainage course will be altered or blocked.

D. The finished project shall be left in a satisfactory condition subject to the approval of the County Engineer. The traveled portion of the roadway shall not be damaged or disturbed. The property owner, organization or authorized representative assumes all liability and agrees to reimburse Woodbury County for any damage to the roadway or ditch caused by placement of this structure. Permittee is to call County Engineer for upon completion for final inspection.

E. The property owner, organization or authorized representative shall notify all appropriate telephone and utility companies in advance of any excavation and shall check for underground electric or telephone lines.



F. Woodbury County will not assume any of the cost of the construction of the said improvement or structure nor will Woodbury County assume any future costs for maintenance or replacement of said improvement or structure. If in the best interest of Woodbury County, the said improvement or structure may be removed by the County, or may be caused to be removed, without any obligation by Woodbury County to pay damages or cost of replacement.

G. Property owner, organization or authorized representative will reseed and mulch the disturbed areas. Property owner, organization or authorized representative will be responsible for seed, mulch, and labor unless otherwise provided in section L.

H. **The property owner, organization, or authorized representative hereby agrees to hold Woodbury County and the Woodbury County Secondary Road Department, its employees and agents harmless against any and all claims for damages and personal injury arising out of work performed or actions taken by the applicant related to the construction or maintenance of the facility. The applicant further agrees to reimburse the County or the Department for any expenditures that the County or Department may have to make on said highway rights of way on account of said applicant's construction or maintenance activity or other activities or lack thereof. The applicant shall also save Woodbury County and the Woodbury County Secondary Road Department harmless of any damage or losses that may be sustained by the traveling public on account of such construction, repair or maintenance operations, or other activities.**

I. **FAILURE TO CONFORM TO OR TO ACQUIRE A PERMIT IS A VIOLATION OF SECTION 318.8, 2009 CODE OF IOWA.** This permit is subject to any laws now in effect or any laws that may be hereafter enacted and all applicable rules and regulations of local, state and federal agencies. This permit is subject to all the rules and regulations of Woodbury County and the Woodbury County Secondary Road Department.

J. This permit is subject to revocation by the Department at any time and at no cost to the Department, when in the judgment of the Department it is necessary in the improvement or maintenance of the highway or for other reasonable cause.

K. All proposed work covered by this permit shall be at the applicant's expense. The applicant shall reimburse the Woodbury County Secondary Road Department for any materials removed from the highway right of way described as follows:

Permittee shall be responsible for providing barricades & signage for road closure.

Permittee shall be responsible for all spill cleanup & mitigation

Permittee shall provide a 48 hour notice of road closures.

L. Woodbury County agrees to provide the following contribution toward completion of this project:

None

M. All work done by property owner, organization or authorized representative pursuant to this agreement shall be completed prior to the 1st day of December, 2023.

Entered into this \_\_\_\_\_ day of \_\_\_\_\_, 2023.

\_\_\_\_\_  
Signature of Property Owner or Authorized Representative



\_\_\_\_\_  
Woodbury County Engineer

\_\_\_\_\_  
Chair, Woodbury County Board of Supervisors

# STF SLUDGE LAND APPLICATION

## LAND MAP

### LEGEND

-  - ROAD CLOSURE
-  - HOSE PATH
-  - EXISTING CULVERT TO BE UTILIZED

**STF LAGOON LOCATION**

Will be utilizing a pipe bridge to cross road at intersection of Allison Av.e & 225th St.  
<https://fortequip.com/#ourproduct>  
Pipe Bridge Duration: 1.5 Weeks

Requesting permission from Woodbury County to close road and cross 235th St. with a hose to land apply. Only 10' of road would need to be closed  
Road Closed Duration: 2 Days

Requesting permission from Woodbury County to lay hose in ditch along the south side of 240th St & West side of Allison Ave heading south. Several farmers have access roads to their land along this road so we will utilize existing culverts along this route which allows farmers to maintain access.  
Duration In Place: 1.5 Weeks

Requesting permission from Woodbury County to cross Allison diagonally at corner of 240th St. & Allison Ave with a hose to land apply. Traffic from Allison to CF would need to take 235th street over to Andrew Ave. to drive around temporary closure. Closure expected to only be required for a few hours.  
Road Closed Duration: .5 Days



SIGN PLACEMENT ON  
TYPE III BARRICADES





Typical Sign Placement



Sign Placement with  
Supplemental Sign

Possible Contract Items:  
Traffic Control  
Safety Closures  
Portable Dynamic Message Sign

Possible Tabulation:  
108-13A

	REVISION
	6   04-21-20
STANDARD ROAD PLAN	TC-252
SHEET 1 of 3	
REVISIONS: Added Portable Dynamic Message Sign and new role 4 on Sheet 2.	
 <small>APPROVED BY DESIGN METHODS ENGINEER</small>	
<b>ROUTES CLOSED TO TRAFFIC</b>	

**SITUATION 1 (RURAL)**  
Project Route Closure

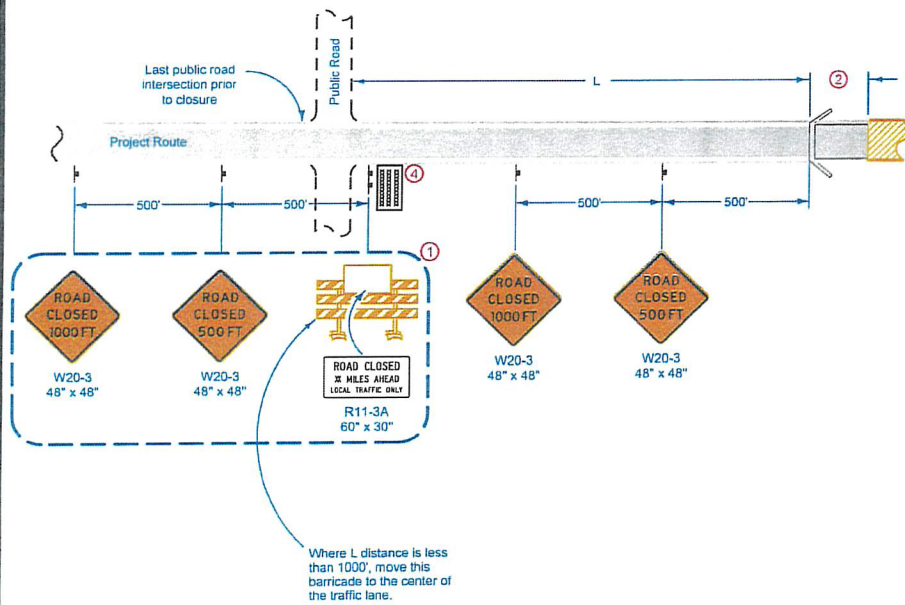

Where L distance is less than 1000', move this barricade to the center of the traffic lane.

**SITUATION 1 (URBAN)**  
Project Route Closure

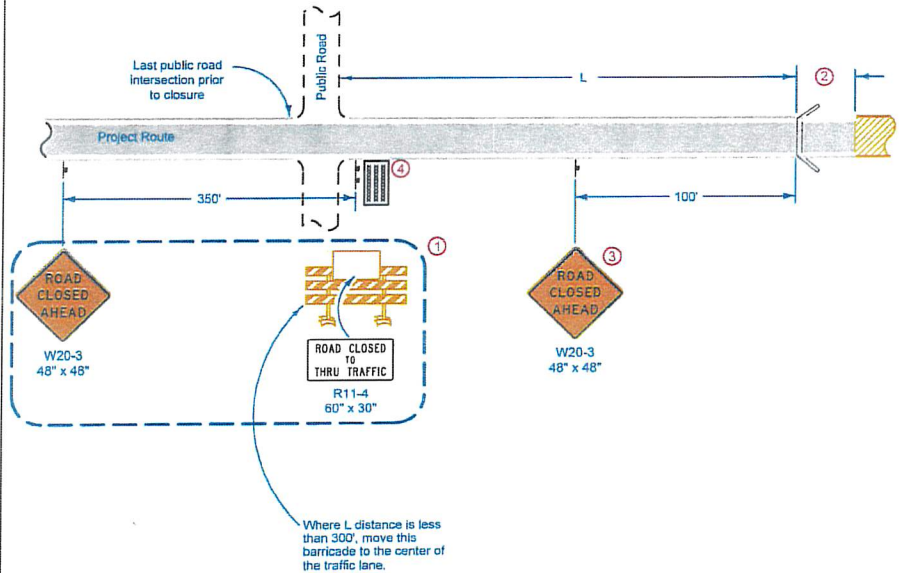

Where L distance is less than 300', move this barricade to the center of the traffic lane.

**LEGEND**

- Traffic Sign
- Type III Barricade
- Portable Dynamic Message Sign
- Work Area
- Road Closure

- ① In situation 1, if the intersection is the point of detour these signs and barricade will become the responsibility of the contracting authority and may be modified by the contracting authority to fit detour signing.
- ② When possible, a 100' buffer is desirable.
- ③ When L is less than 300 feet, omit the ROAD CLOSED AHEAD sign.
- ④ Place for 7 calendar days prior to closure. The Engineer will determine the message to display. Remove when road is closed. Use of Portable Dynamic Message Sign is optional on non-primary roadways.

	REVISION 6   04-21-20
	<b>TC-252</b>
SHEET 2 of 3	

REVISIONS: Added Portable Dynamic Message Sign and new note 4 on Sheet 2.

*Scott Miller*  
APPROVED BY REGION METHODS ENGINEER

**ROUTES CLOSED TO TRAFFIC**

**SITUATION 2**

Public cross-traffic maintained.  
No access to project.

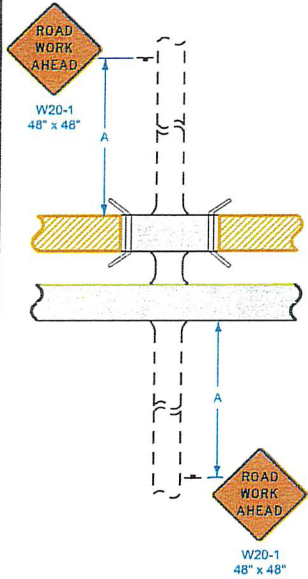

**SITUATION 3**

No access to project  
(Applicable to T-intersections)

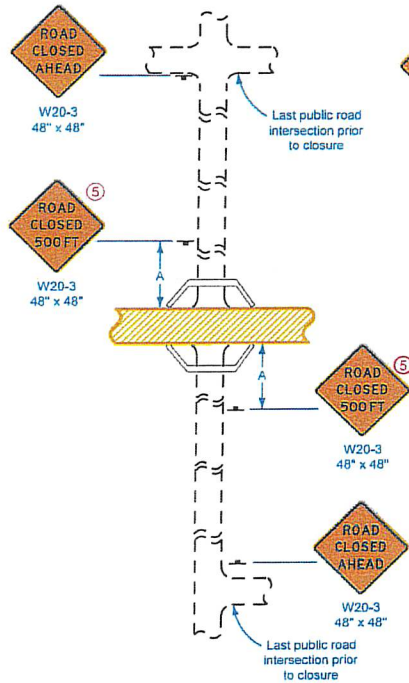

**SITUATION 4**

Public cross-traffic maintained.  
No access to project.

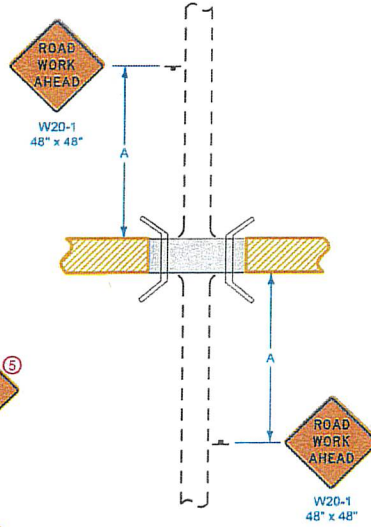

**SITUATION 5**

Public cross-traffic maintained.  
Contractor and resident access.

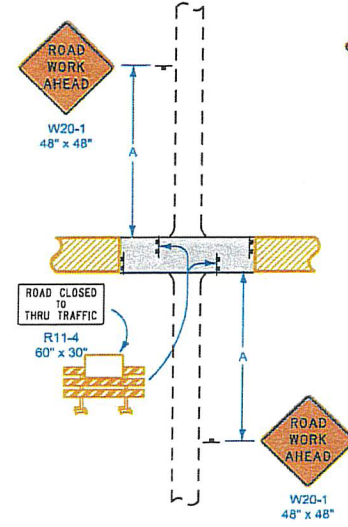

**SITUATION 6**

No public access. Contractor and resident  
access only. (Applicable to T-intersections)

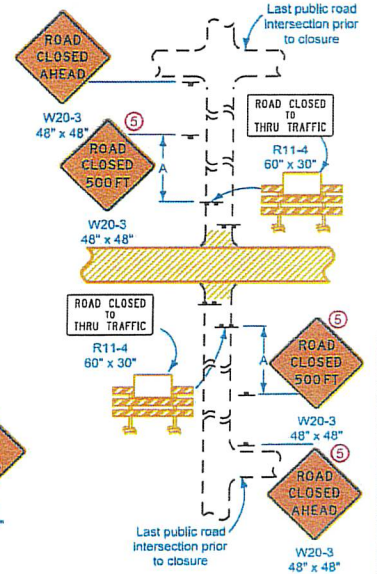

**LEGEND**

- Traffic Sign
- Type III Barricade
- Work Area
- Road Closure

Location	A
Urban	200'
Rural	500'

During suspension of work, (such as over winter):

- Use Situation 2 on two-lane to four-lane projects.
- Situation 5 is preferred where cross-traffic is maintained.

⑤ When the distance between the last public road intersection and the ROAD CLOSED or ROAD CLOSED TO THRU TRAFFIC barricade is less than 1,000 feet, omit the ROAD CLOSED 500 FT sign.

 <b>STANDARD ROAD PLAN</b>	<small>REVISION</small> 6 04-21-20
	<b>TC-252</b> <small>SHEET 3 of 3</small>
	REVISIONS: Added Portable Dynamic Message Sign and new note 4 on Sheet 2.
 <small>APPROVED BY DESIGN METHODS ENGINEER</small>	
<b>ROUTES CLOSED TO TRAFFIC</b>	

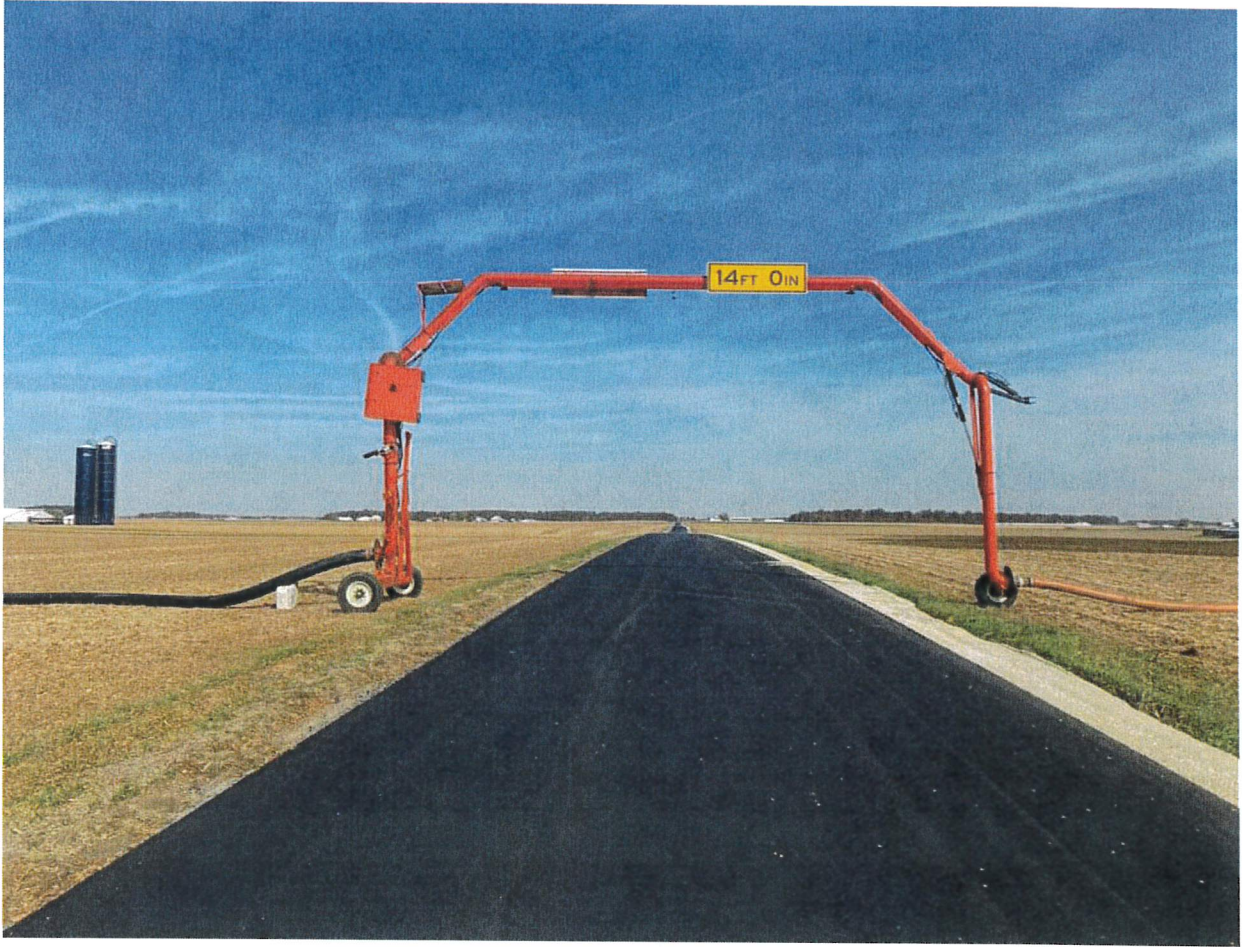

# HUMAN RESOURCES DEPARTMENT

## MEMORANDUM OF PERSONNEL TRANSACTIONS

**DATE:** November 7, 2023

**\* PERSONNEL ACTION CODE:**

- |                 |                      |
|-----------------|----------------------|
| A - Appointment | R - Reclassification |
| T - Transfer    | E - End of Probation |
| P - Promotion   | S - Separation       |
| D - Demotion    | O - Other            |

**TO: WOODBURY COUNTY BOARD OF SUPERVISORS**

NAME	DEPARTMENT	EFFECTIVE DATE	JOB TITLE	SALARY REQUESTED	% INCREASE	*	REMARKS
Reising, Heidi	County Sheriff	11-01-23	Deputy Sheriff			S	Resignation.
Rayevich, Jesse	Secondary Roads	11-15-23	Motor Grader Operator	\$26.93/hour		A	Job Vacancy Posted 8-30-23. Entry Level Salary: \$26.93/hour.
Shupe, Douglas	Secondary Roads	12-31-23	District Foreman			S	Retirement.
Kusler, Benjamin	Secondary Roads	12-31-23	Assistant to the County Engineer			S	Retirement.

**APPROVED BY BOARD DATE:** \_\_\_\_\_

**MELISSA THOMAS, HR DIRECTOR:** Melissa Thomas HR Director

**HUMAN RESOURCES DEPARTMENT**

**WOODBURY COUNTY, IOWA**

**DATE: November 7, 2023**

**AUTHORIZATION TO INITIATE HIRING PROCESS**

<b>DEPARTMENT</b>	<b>POSITION</b>	<b>ENTRY LEVEL</b>	<b>APPROVED</b>	<b>DISAPPROVED</b>
Secondary Roads	District Foreman	Wage Plan: \$2,859.52- \$3,056.66/ bi-weekly		

\_\_\_\_\_  
Chairman, Board of Supervisors



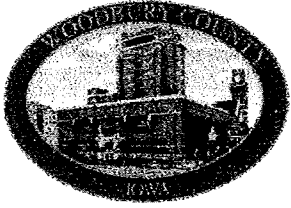

# Woodbury County Secondary Roads Department

759 E. Frontage Road • Merville, Iowa 51039  
Telephone (712) 279-6484 • (712) 873-3215 • Fax (712) 873-3235

COUNTY ENGINEER  
Mark J. Nahra, P.E.  
mnahra@sioux-city.org

ASSISTANT TO THE COUNTY ENGINEER  
Benjamin T. Kusler, E.I.T.  
bkusler@sioux-city.org

SECRETARY  
Tish Brice  
tbrice@sioux-city.org

To: Board of Supervisors  
Human Resources Department

From: Mark Nahra, Woodbury County Engineer

Date: October 27, 2023

Subject: District 3 (Oto) Maintenance Foreman Position

I am requesting that the Board authorize the replacement of Doug Shupe, District 4 (Oto) Maintenance Foreman, who is retiring effective December 31, 2023. Due to his vacation balance, he only has two working days left, with little time on the job in the upcoming weeks between now and the end of the year as he utilizes accumulated leave time. With winter weather approaching, I would like to fill this position quickly, if a suitable applicant can be found.

Since this is not a union position, there is no internal posting requirement and the position can be immediately advertised. Applicants from inside and outside our department can be considered for this position.

Thank you for your consideration.

**WOODBURY COUNTY BOARD OF SUPERVISORS AGENDA ITEM(S) REQUEST FORM**

Date: 11/02/2023 Weekly Agenda Date: 11/07/2023

**ELECTED OFFICIAL / DEPARTMENT HEAD / CITIZEN:** Melissa Thomas HR Director

**WORDING FOR AGENDA ITEM:**

Approval for the Chairman to sign the Delta Dental 2024 Renewal

**ACTION REQUIRED:**

Approve Ordinance

Approve Resolution

Approve Motion

Public Hearing

Other: Informational

Attachments

**EXECUTIVE SUMMARY:**

The paper work for the renewal of Woodbury County's dental plan is being submitted. This renewal lays out the administrative rates, direct bill and COBRA rates for 2024.

**BACKGROUND:**

Delta Dental renews annually on January 1.

**FINANCIAL IMPACT:**

The administrative rates have increased slightly by \$.15 per contract.

**IF THERE IS A CONTRACT INVOLVED IN THE AGENDA ITEM, HAS THE CONTRACT BEEN SUBMITTED AT LEAST ONE WEEK PRIOR AND ANSWERED WITH A REVIEW BY THE COUNTY ATTORNEY'S OFFICE?**

Yes  No

**RECOMMENDATION:**

Pass the motion.

**ACTION REQUIRED / PROPOSED MOTION:**

Accept the 2024 Delta Dental renewal for signature.



Woodbury County  
 Group # 33541  
 Rating Period 1/1/24 through 12/31/24  
 Financial Exhibit

Delta Dental PPO<sup>SM</sup>

Experience Period      Claims Paid 8/1/22 through 7/31/23  
 Claims Paid 8/1/22 through 7/31/23  
 Adjustment of Claims to Incurred Basis  
 Incurred Claims  
 Trend in Claims  
 Projected Claims Based on Current Experience  
 Claims and Enrollment Fluctuation Adjustment  
 Projected Annual Claims Based on Current Enrollment

\$219,050  
 \$6,775  
 \$225,825  
 \$11,269  
 \$237,093  
 \$6,003  
 \$243,096

**Fixed Fees**  
 Operating Costs      \$5.76      \$25,644  
 Broker Fee      \$0.00      \$0

Subtotal Fixed Fees      \$5.76      \$25,644

Projected Annual Expense      \$268,740

Percent of Premium Contributed by Employer: Single 100 % Emp/Spouse 47 % Emp/Child(ren) 39 % Family 27 %

Total Employees Enrolled: 345  
 Total Employees Eligible: 345

Signature of Group Administrator  
 Please sign and return to fax # 888-337-5157 or  
 email to: TeamRenew@deltadentalia.com

E-Mail Address

DELTA DENTAL OF IOWA

Date

		Current Enrollment		
	Single	E/S	E/C	Family
	177	72	38	84
Projected Claim Factors 1/1/24 through 12/31/24				
Single	\$27.66	E/S \$58.32	E/C \$70.46	Family \$101.03
Fixed Fees				
Cost Per Contract				
Current	\$5.76	2024 \$5.91		
Suggested Rates 1/1/24 through 12/31/24				
Single	\$30.57	E/S \$64.47	E/C \$77.89	Family \$111.69
Direct Bill Rates 1/1/24 through 12/31/24				
Single	\$30.84	E/S \$65.02	E/C \$78.28	Family \$112.81
COBRA Direct Bill Rates 1/1/24 through 12/31/24				
Single	\$31.46	E/S \$66.32	E/C \$79.84	Family \$115.07

The Direct Bill Rates above will be the amount charged unless desired rates are communicated to DDIA at least 45 days prior to the start of this contract period.

**WOODBURY COUNTY BOARD OF SUPERVISORS AGENDA ITEM(S) REQUEST FORM**

Date: 11/2/2023 Weekly Agenda Date: 11/7/2023

**ELECTED OFFICIAL / DEPARTMENT HEAD / CITIZEN:** Mark J. Nahra, County Engineer

**WORDING FOR AGENDA ITEM:**

Woodbury County receives National Paving recognition

**ACTION REQUIRED:**

Approve Ordinance

Approve Resolution

Approve Motion

Public Hearing

Other: Informational

Attachments

**EXECUTIVE SUMMARY:**

American Concrete Paving Association has recognized Woodbury County for its 2023 National Lifetime Pavement Recognition Award.

**BACKGROUND:**

Old Highway 20 near Merville, now known as Frontage Road, was recognized for showing "remarkable longevity, durability and resilience". The highway is one of the oldest highways in the region and is over 101 years old. It is one of a few highways of this era that remains in continuing service anywhere in the nation.

**FINANCIAL IMPACT:**

Travel expenses for our assistant county engineer to attend the meeting and receive the award on behalf of the county.

**IF THERE IS A CONTRACT INVOLVED IN THE AGENDA ITEM, HAS THE CONTRACT BEEN SUBMITTED AT LEAST ONE WEEK PRIOR AND ANSWERED WITH A REVIEW BY THE COUNTY ATTORNEY'S OFFICE?**

Yes  No

**RECOMMENDATION:**

No recommendation. Information only.

**ACTION REQUIRED / PROPOSED MOTION:**

No motion required.



AMERICAN CONCRETE PAVEMENT ASSOCIATION

9450 W. Bryn Mawr Ave.  
Suite 150  
Rosemont, IL 60018  
Phone: 847-966-2272

October 26, 2023

Mark J. Nahra, P.E.  
Woodbury County Engineer  
759 E. Frontage Road  
Menville, IA 51039

Dear Mark,

On behalf of the members and staff of the American Concrete Pavement Association, I am very happy to inform you that we have selected Old State Highway 20 in Woodbury County, IA for the 2023 National Lifetime Pavement Recognition Award. Our association presents this award to an agency/owner of an in-service concrete pavement that has demonstrated exceptional performance for its state, community, and for local users.

After over 100 years of service, Old State Highway 20 in Woodbury County Iowa has shown remarkable longevity, durability, and resilience. The highway holds immense historical significance as one of the oldest highways in the region. It served as a pioneering example of concrete pavement technology during the early 20<sup>th</sup> century and represents a crucial milestone in the evolution of transportation infrastructure. The longevity despite extreme weather, continuous traffic and other environmental exposure with only minimal maintenance has been truly remarkable. Old Highway 20 tells the concrete paving story, and we are truly honored to celebrate its longevity.

We'll have much more to say at ACPA's Distinguished Service Awards luncheon on Thursday, December 14<sup>th</sup>, from noon to 1:00 pm. The ceremony is part of our 60<sup>th</sup> Annual Meeting in Marco Island, FL. I hope you will join us in Nashville to receive this prestigious award during the luncheon. As an agency employee, your registration to attend the luncheon is complimentary. Please contact Amber Davis ([adavis@acpa.org](mailto:adavis@acpa.org)) for registration assistance. Congratulations again, and I hope to have the pleasure of meeting you in person at the 60<sup>th</sup> Annual Meeting.

Sincerely,

A handwritten signature in black ink, appearing to read "Laura O'Neill Kaumo". The signature is fluid and cursive, with a large initial "L" and "K".

Laura O'Neill Kaumo  
President & CEO  
American Concrete Pavement Association

CC: Steve Friess, Milestone Contractors LLC; 2023 ACPA Chairman  
Greg Mulder, Iowa Concrete Pavement Association

**WOODBURY COUNTY BOARD OF SUPERVISORS AGENDA ITEM(S) REQUEST FORM**

Date: 10/30/2023

Weekly Agenda Date: 11/7/2023

**ELECTED OFFICIAL / DEPARTMENT HEAD / CITIZEN:** Supervisors J. Taylor/D. Bittinger

**WORDING FOR AGENDA ITEM:**

Resolution to Highlight the Accomplishments and Service of Veterans in Woodbury County and Authorize \$1,340 for Further Outreach to Veterans in November of 2023

**ACTION REQUIRED:**

Approve Ordinance

Approve Resolution

Approve Motion

Public Hearing

Other: Informational

Attachments

**EXECUTIVE SUMMARY:**

Woodbury County has an outstanding level of service and sacrifice that veterans and their families have made in several different wars over the last 172 years (see backup of Iowa's historic conflicts courtesy of the Camp Dodge Museum). In order to highlight the fact that the "Soldier serves and the family sacrifices," we as supervisors, our Veterans Affairs Department, and our Woodbury County Veterans Affairs Commission want to highlight the incredible contributions interwoven into the fabric of our community.

Our goal is to have a 3-fold approach this Veterans Day and during the month of November:

Events: Wed Nov 8 Sgt. Bluff Legion Pancake Feed (8-10 am) Honoring Veterans and Offering VA Services as Part of Outreach  
Sat Nov 11 Woodbury County Courthouse Veterans Day Ceremony (11 am) at the Courthouse (see attached flyers)

Awareness: Green-light Woodbury County Courthouse, the Tri-View Veterans Affairs Building and Woodbury County homes.  
Create Public Service Announcements (PSAs) on the Big 5 Radio Stations for a 3-Day Period.

Resolution: Pass the attached resolution.

**BACKGROUND:**

Armistice Day: Armistice Day, later known as Remembrance Day in the Commonwealth and Veterans Day in the United States, is commemorated every year on 11 November to mark the armistice signed between the Allies of World War I and Germany at Compiègne, France, at 5:45 am for the cessation of hostilities on the Western Front of World War I, which took effect at eleven in the morning—the "eleventh hour of the eleventh day of the eleventh month" of 1918. This should hold an especially poignant meaning for Woodbury County given the symbolism within our courthouse, a John Warner Norton 1919 commissioned mural commemorating the Soldiers and families of World War I. Traditionally the name of the first person who gave his life on the battlefields of France for his country became the name of the post in the community in which he lived. Thus the name of Edward H. Monahan was immortalized by his former comrades in Sioux City after he was wounded in action fighting in the Lorraine sector and died of his wounds a few days later at Baccarat. Private Monahan was awarded the Croix de Guerre by General Segonne, Commander of the 128th Division.

Back in 2018 (the centennial) when we celebrated our county courthouse's history, we recognized the role that the Monahan Post and the Red Cross played within these courthouse walls. A plaque hangs in our courthouse made from the hull of the USS Maine, a United States Navy ship that sank along with 230 souls in Havana Harbor on February 15, 1898, which contributed to the outbreak of the Spanish–American War.

This November, we propose Operation Greenlight for Veterans: Along with NACO, ISAC encourages Iowa counties to join Operation Green Light to show support for veterans. This initiative aims to "shine a light" on issues and challenges veterans face, particularly as they transition to civilian life. Along with our state and federal partners, counties serve veterans every day as they take on these challenges.

Our Veterans Affairs Department also exists Our Mission assists Woodbury County's Veterans and their legal dependents in obtaining and maintaining any and all Veteran's benefits to which they may be entitled.

See attached "Woodbury County Resolution for Veterans" and "Woodbury County VA Department Statistics"

**FINANCIAL IMPACT:**

\$840 for 120 spots (a "buy 12, get 12 free) special for Q102, Y Country, KKMA, KSCJ, and KSUX for PSA announcements sharing appreciation for the services and sacrifices of veterans plus offering services at the Triview Building.

Up to \$500 for green-lighting the Woodbury County Courthouse and Tri-View Building (and also potentially giving extra bulbs to community members/veterans who are willing to help show support). These could be used each year for this purpose.

Source of funds: gaming revenue

**IF THERE IS A CONTRACT INVOLVED IN THE AGENDA ITEM, HAS THE CONTRACT BEEN SUBMITTED AT LEAST ONE WEEK PRIOR AND ANSWERED WITH A REVIEW BY THE COUNTY ATTORNEY'S OFFICE?**

Yes  No

**RECOMMENDATION:**

Motion to Authorize \$1,340 from gaming revenues to highlight and support veterans and their families during the month of November.

Motion to pass the attached resolution.

**ACTION REQUIRED / PROPOSED MOTION:**

Motion to Authorize \$1,340 from gaming revenues to highlight and support veterans and their families during the month of November.

Motion to pass the attached resolution.

## Karen James

---

**From:** Loni Kuhlmann  
**Sent:** Friday, November 3, 2023 8:45 AM  
**To:** Karen James; Heather Satterwhite; Jeremy Taylor  
**Subject:** County Stats

Here are some fun facts about the office:

Woodbury County:  
September Numbers

Live Compensation  
Count : 1,460  
Gross Amount: \$2,071,014

Live Pension  
Count: 42  
Gross Amount: \$32,466

Survivor Benefits  
Count: 21  
Gross Amount: \$10,179

DIC Benefits  
Count: 140  
Gross Amount: \$223,997

Grand Total  
Count: 1,663  
Gross Amount: \$2,337,657

Number of Clients in the office last month: 200 roughly

*Loni Kuhlmann, Executive Director*  
*Woodbury County Commission of Veteran Affairs*  
1211 Tri View Ave  
Sioux City, IA 51103  
Phone: (712) 279-6605 or 6606  
Fax: (712) 224-4093  
Email: [lkuhlmann@woodburycountyiowa.gov](mailto:lkuhlmann@woodburycountyiowa.gov)

**From:** Jeremy Taylor <[jtaylor@woodburycountyiowa.gov](mailto:jtaylor@woodburycountyiowa.gov)>  
**Sent:** Thursday, November 2, 2023 9:32 PM  
**To:** Loni Kuhlmann <[lkuhlmann@woodburycountyiowa.gov](mailto:lkuhlmann@woodburycountyiowa.gov)>  
**Subject:** Re:



## Woodbury County Resolution for Veterans

WHEREAS, the residents of Woodbury County have great respect, admiration, and the utmost gratitude for all the men and women who have selflessly served our country and this community in the Armed Forces; and

WHEREAS, the contributions and sacrifices of those who served in the Armed Forces have been vital in maintaining the freedoms and way of life enjoyed by our citizens; and

WHEREAS, Woodbury County seeks to honor individuals who have made countless sacrifices for freedom by placing themselves in harm's way for the good of all; and

WHEREAS, veterans continue to serve our community in the American Legion, Veterans of Foreign Wars, religious groups, civil service, and by functioning as County Veterans Service Officers in 29 states to help fellow former service members access more than \$52 billion in federal health, disability and compensation benefits each year; and

WHEREAS, Approximately 200,000 service members transition to civilian communities annually; and

WHEREAS, an estimated 20 percent increase of service members will transition to civilian life in the near future; and

WHEREAS, studies indicate that 44-72 percent of service members experience high levels of stress during transition from military to civilian life; and

WHEREAS, active military service members transitioning from military service are at a high risk for suicide during their first year after military service; and

WHEREAS, the National Association of Counties encourages all counties, parishes and boroughs to recognize Operation Green Light for Veterans; and

WHEREAS, the Woodbury County appreciates the sacrifices of our United States military personnel and believes specific recognition should be granted; therefore be it

RESOLVED, with designation as a Green Light for Veterans County, Woodbury County hereby declares the month of November and especially Veterans Day, November 11<sup>th</sup> 2023 a time to salute and honor the service and sacrifices of our men and women in uniform transitioning from active service; therefore, be it further

RESOLVED, that in observance of Operation Green Light, Woodbury County encourages its citizens in patriotic tradition to recognize the importance of honoring all those who made immeasurable sacrifices to preserve freedom by displaying green lights in a window of their place of business or residence from November 7th through the 30th, 2023.

BE IT RESOLVED this 7<sup>th</sup> day of November 2023

### WOODBURY COUNTY BOARD OF SUPERVISORS

---

Matthew A. Ung, Chairman

---

Daniel A. Bittinger II, Member

---

Mark E. Nelson, Member

---

Keith W. Radig, Member

---

Jeremy J. Taylor, Member

ATTEST:

---

Patrick F. Gill, County Auditor



**Come celebrate Veterans Day early  
with the Woodbury County  
Commission of Veteran Affairs!**



## **VETERANS PANCAKE BREAKFAST**

---

**WEDNESDAY, NOVEMBER 8, 2023**

**8 - 10 AM**

**SGT BLUFF AMERICAN LEGION POST 662  
901 E TOPAZ DR.**

**ALL VETERANS, SPOUSES AND FAMILY MEMBERS ARE WELCOME!**



Woodbury County Veteran Affairs  
1211 Tri View Ave, Ste A  
Sioux City, IA 51106  
712-279-6606



## OPERATION DESERT STORM 1990-1991

Major Campaigns of Operation Desert Storm

- Defense of Saudi Arabia, 2 August 1990 to 16 January 1991
- Liberation and Defense of Kuwait, 17 January 1991 to 01 April 1991
- Cease-Fire, 12 April 1991 to 30 November 1995

More than 3,000  
Iowans bore arms.  
7 were casualties.

★ Denotes Iowa troop involvement.

## WAR ON TERRORISM 2001-Present

Global War on Terrorism

- 11 September 2001 to Present

Afghanistan Campaigns

- Liberation of Afghanistan, 11 September 2001 to 30 November 2001
- Consolidation I, 1 December 2001 to 30 September 2006
- Consolidation II, 1 October 2006 to 30 November 2009
- Consolidation III, 1 December 2009 to 30 June 2011
- Transition I, 1 July 2011 to 31 December 2014

Iraq Campaigns

- Liberation of Iraq, 19 March 2003 to 1 May 2003
- Transition of Iraq, 2 May 2003 to 28 June 2004
- Iraqi Governance, 29 June 2004 to 15 December 2005
- National Resolution, 16 December 2005 to 9 January 2007
- Iraqi Surge, 10 January 2007 to 31 December 2008
- Iraqi Sovereignty, 1 January 2009 to 31 August 2010
- New Dawn, 1 September 2010 to 31 December 2011

More than 17,000 Iowans  
have borne arms to date.

## KOREAN WAR 1950-1953

## VIETNAM WAR 1959-1975

### MAJOR CAMPAIGNS OF THE KOREAN WAR

- UN Defensive, 27 June to 15 September 1950
- UN Offensive, 16 September to 2 November 1950
- CCF Intervention, 3 November 1950 to 24 January 1951
- First UN Counteroffensive, 25 January to 21 April 1951
- CCF Spring Offensive, 22 April to 8 July 1951
- UN Summer-fall Offensive, 9 July to 27 November 1951
- Second Korean Winter, 28 November 1951 to 30 April 1952
- Korea, Summer-Fall, 1 May to 30 November 1952
- Third Korean Winter, 1 December 1952 to 30 April 1953
- Korea, Summer, 1 May to 27 July 1953

85,314 Iowans bore arms.  
508 were casualties.

### MAJOR CAMPAIGNS OF THE VIETNAM WAR

- Advisory, 15 March 1962 to 7 March 1965
- Defeat, 8 March to 24 December 1965
- Counteroffensive, 25 December 1965 to 30 June 1966
- Counteroffensive, Phase II, 1 July 1966 to 31 May 1967
- Counteroffensive, Phase III, 1 June 1967 to 29 January 1968
- Tet Counteroffensive, 30 January to 1 April 1968
- Counteroffensive, Phase IV, 2 April to 30 June 1968
- Counteroffensive, Phase V, 1 July to 1 November 1968
- \* Counteroffensive, Phase VI, 2 November 1968 to 22 February 1969
- \* Tet 69 Counteroffensive, 23 February to 8 June 1969
- \* Summer-Fall, 9 June to 31 October 1969
- Winter-Spring, 1 November 1969 to 30 April 1970
- Sanctuary Counteroffensive, 1 May to 30 June 1970
- Counteroffensive, Phase VII, 1 July 1970 to 31 June 1971
- Consolidation I, 1 July to 30 November 1971
- Consolidation II, 1 December 1971 to 29 March 1972
- Cease-Fire, 30 March 1972 to 28 January 1973

More than 115,000 Iowans bore arms.  
860 were casualties.

★ Denotes Iowa troop involvement.

# WORLD WAR II 1941-1945

## Major Campaigns of the European Theater

- Luftwaffe: 11 June 1941 to 12 February 1943
- Air Offensive: Europe: 4 July 1942 to 5 June 1945
- Spain-French Morocco: 8 to 11 November 1942
- Tunisia: 17 November 1942 to 12 May 1943
- Italy: 9 July to 17 August 1943
- Balkan Front: 8 September 1943 to 23 January 1944
- Axis: 22 January to 28 May 1944
- West-Asia: 22 January to 3 September 1944
- Germany: 8 June to 24 July 1944
- Northern France: 25 July to 14 September 1944
- Western France: 15 August to 14 September 1944
- North-West Europe: 15 September 1944 to 4 April 1945
- Western: 6 September 1944 to 21 March 1945
- Western-Axis: 31 December 1944 to 25 January 1945
- Central Europe: 22 March to 11 May 1945
- Alsace: 3 April to 8 May 1945



## Major Campaigns of the Pacific Theater

- Philippine Islands: 7 December 1941 to 10 May 1942
- Burma: 7 December 1941 to 26 May 1942
- Central Pacific: 7 December 1941 to 6 December 1943
- East Indies: 1 January to 22 July 1942
- Indo-China: 2 April 1942 to 28 January 1945
- Air Offensive: Japan: 11 April 1942 to 2 September 1945
- Aleutian Islands: 3 June 1942 to 24 August 1942
- China Offshoots: 4 July 1942 to 4 May 1945
- Papua: 25 July 1942 to 23 January 1943
- Guadalcanal: 7 August 1942 to 21 February 1943
- New Guinea: 24 January 1943 to 21 December 1944
- Northern Solomon: 22 February 1943 to 23 November 1944
- Eastern Mikoto: 31 January to 14 June 1944
- Iwojima: 15 December 1943 to 27 November 1944
- Western Pacific: 15 June 1944 to 2 September 1945
- Leyte: 7 October 1944 to 1 July 1945
- Luzon: 15 December 1944 to 4 July 1945
- Central Burma: 26 January to 15 July 1945
- Southern Philippines: 27 February to 4 July 1945
- Ryukyu: 26 March to 2 July 1945
- Chou Offshoots: 6 May to 2 September 1945

262,638 Iowans bore arms.

8,398 were casualties.

★ Denotes Iowa troop involvement

**THE SPANISH AND AMERICAN WAR 1898**

**MAJOR CAMPAIGNS OF THE SPANISH AND AMERICAN WAR**

- Santiago, 22 June to 11 July 1898
- Puerto Rico, 23 July to 13 August 1898
- Manila, 11 July to 13 August 1898

*Philippine Islands*

**WORLD WAR I 1917 TO 1918**

**MAJOR CAMPAIGNS OF WORLD WAR I**

- Cambrai, 20 November to 4 December 1917
- Somme Defensive, 21 March to 6 April 1918
- Lys, 9 April to 27 April 1918
- Alsne, 27 May to 5 June 1918
- Moonsdrier-Noyon, 9 June to 13 June 1918
- ★ Champagne-Marne, 15 July to 18 July 1918
- ★ Aisne-Marne, 18 July to 6 August 1918
- Somme Offensive, 8 August to 11 November 1918
- Oise-Aisne, 18 August to 11 November 1918
- Ypres-Lys, 19 August to 11 November 1918
- ★ St. Mihiel, 12 September to 16 September 1918
- ★ Meuse-Argonne, 26 September to 11 November 1918
- Vittoria Veneto, 24 October to 4 November 1918

More than 5,600 Iowans bore arms. 164 were casualties.

114,242 Iowans bore arms. 3,576 were casualties.

★ Denotes Iowa troop involvement.

## The Civil War 1861 - 1865

76,534 Iowans bore arms.  
13,167 were casualties.

### Major Campaigns of the Civil War

- ★ Sumter, 12 April to 13 April 1861
- Bull Run, 18 July to 22 July 1861
- ★ Henry & Donelson, 6 February to 16 February 1862
- ★ Mississippi River, 6 February 1862 to 9 July 1862
- Peninsula, 17 March to 3 August 1862
- ★ Shiloh, 6 April to 7 April 1862
- Valley, 15 May to 17 June 1862
- Manassas, 7 August to 2 September 1862
- Antietam, 3 September to 17 September 1862
- Fredericksburg, 9 November to 15 December 1862
- Murfreesborough, 25 December 1862 to 4 January 1863
- Chancellorsville, 23 April to 6 May 1863
- Gettysburg, 29 June to 3 July 1863
- ★ Vicksburg, 29 March to 4 July 1863
- Chickamauga, 18 August to 23 September 1863
- ★ Chattanooga, 23 November to 27 November 1863
- Wilderness, 4 May to 7 May 1864
- ★ Atlanta, 7 May to 2 September 1864
- Spotsylvania, 8 May to 21 May 1864
- Cold Harbor, 22 May to 3 June 1864
- Petersburg, 4 June 1864 to 2 April 1865
- ★ Shenandoah, 7 August to 28 November 1864
- Franklin, 17 November to 30 November 1864
- ★ Nashville, 1 December to 16 December 1864
- Appomattox, 3 April to 9 April 1865

★ Denotes Iowa troop involvement.



## War of 1812 1812-1815

## Mexican War 1846-1848

*British Indian Allies forced the withdrawal of US troops from Fort Madison in 1813. US troops burned the fort to prevent its capture.*

**MAJOR CAMPAIGNS OF THE WAR OF 1812**

- Canada, 18 June 1812 to 17 February 1815
- Chippewa, 5 July 1814
- Lundy's Lane, 25 July 1814
- Bladensburg, 17 August to 29 August 1814
- McHenry, 13 September 1814
- New Orleans, 23-September 1814 to 8 January 1815

**MAJOR CAMPAIGNS OF THE MEXICAN WAR**

- Palo Alto, 8 May 1846
- Resaca de la Palma, 9 May 1846
- Monterey, 21 September 1846
- Buena Vista, 22 February to 23 February 1847
- ★ Vera Cruz, 9 March to 29 March 1847
- Cerro Gordo, 17 April 1847
- Contreras, 18 August to 20 August 1847
- ★ Churubusco, 20 August 1847
- Molino del Rey, 8 September 1847
- ★ Chapultepec, 13 September 1847

1,038 Iowans bore arms.  
78 were casualties.  
★ Denotes Iowa troop involvement.

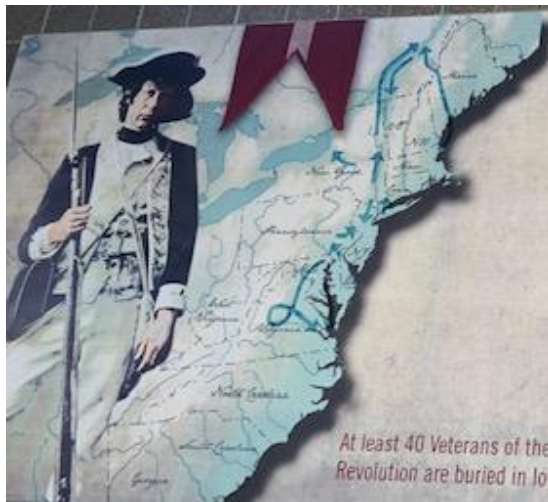

## *The American Revolution 1775-1781*

Major Campaigns of the American Revolution

- Lexington, 19 April 1775
- Ticonderoga, 10 May 1775
- Boston, 17 June 1775 to 17 March 1776
- Quebec, 28 August 1775 to 3 July 1776
- Charleston, 28 June to 29 June 1776; 29 March to 12 May 1780
- Long Island, 26 August to 29 August 1776
- Trenton, 26 December 1776
- Princeton, 3 January 1777
- Saratoga, 2 July to 17 October 1777
- Brandywine, 11 September 1777
- Germantown, 4 October 1777
- Monmouth, 28 June 1778
- Savannah, 29 December 1778; 16 September to 10 October 1779
- Cowpens, 17 January 1781
- Guilford Court House, 15 March 1781
- Yorktown, 28 September to 19 October 1781

*At least 40 Veterans of the  
Revolution are buried in Iowa.*

**WOODBURY COUNTY BOARD OF SUPERVISORS AGENDA ITEM(S) REQUEST FORM**

Date: 11/3/23 Weekly Agenda Date: 11/7/23

**ELECTED OFFICIAL / DEPARTMENT HEAD / CITIZEN:** Supervisor Mark Nelson

**WORDING FOR AGENDA ITEM:**

Give direction to the LEC Authority on placement of meeting recordings

**ACTION REQUIRED:**

Approve Ordinance

Approve Resolution

Approve Motion

Public Hearing

Other: Informational

Attachments

**EXECUTIVE SUMMARY:**

The LEC Authority has been requested to record their public meetings. The Authority needs to have a place to publish the recordings.

**BACKGROUND:**

In prior Supervisor meetings, supervisors have requested the LEC Authority's public meetings be recorded so that anyone could watch the meetings after the fact. The Authority has the capability to do so, but needs to find a home to publish the recordings. Auditor Pat Gill has advised that the BOS should decide and vote on the proper home for the recordings.

**FINANCIAL IMPACT:**

None

**IF THERE IS A CONTRACT INVOLVED IN THE AGENDA ITEM, HAS THE CONTRACT BEEN SUBMITTED AT LEAST ONE WEEK PRIOR AND ANSWERED WITH A REVIEW BY THE COUNTY ATTORNEY'S OFFICE?**

Yes  No

**RECOMMENDATION:**

Decide if the recordings should be published on the county website or the LEC Authority website.

**ACTION REQUIRED / PROPOSED MOTION:**

Pass a motion giving direction.