



NOTICE OF MEETING OF THE WOODBURY COUNTY BOARD OF SUPERVISORS
(MARCH 21, 2017) (WEEK 12 OF 2017)

NOW LIVE STREAMING!



<https://www.youtube.com/watch?v=7QQ0sePQEtI>

Agenda and Minutes also available at
www.woodburycountyiowa.gov

Rocky L. DeWitt Marty J. Pottebaum Keith W. Radig Jeremy J. Taylor Matthew A. Ung
253-0421 251-1799 560-6542 259-7910 490-7852
rdewitt@woodburycountyiowa.gov mpottebaum@woodburycountyiowa.gov kradig@woodburycountyiowa.gov jtaylor@woodburycountyiowa.gov matthewung@woodburycountyiowa.gov

You are hereby notified a meeting of the Woodbury County Board of Supervisors will be held March 21, 2017 at **4:30 p.m.** in the Basement of the Courthouse, 620 Douglas Street, Sioux City, Iowa for the purpose of taking official action on the agenda items shown hereinafter and for such other business that may properly come before the Board.

This is a formal meeting during which the Board may take official action on various items of business. If you wish to speak on an item, please follow the seven participation guidelines adopted by the Board for speakers.

1. Anyone may address the Board on any agenda item after initial discussion by the Board.
2. Speakers will approach the microphone one at a time and be recognized by the Chair.
3. Speakers will give their name, their address, and then their statement.
4. Everyone will have an opportunity to speak. Therefore, please limit your remarks to **three minutes on any one item.**
5. At the beginning of the discussion on any item, the Chair may request statements in favor of an action be heard first followed by statements in opposition to the action.
6. Any concerns or questions you may have which do not relate directly to a scheduled item on the agenda will also be heard under the first or final agenda item "Citizen Concerns."
7. For the benefit of all in attendance, please turn off all cell phones and other devices while in the Board Chambers.

AGENDA

- 4:10 p.m.** 1. Closed Session - General Relief Appeal Hearing for C. S. {Iowa Code Section 21.5 (1) (a)}
First Floor Board of Supervisors Meeting Room
- 4:30 p.m.** 2. Call Meeting to Order – Pledge of Allegiance to the Flag – Moment of Silence
3. Citizen Concerns Information
4. Approval of the agenda March 21, 2017 Action

Consent Agenda

Items 5 through 9 constitute a Consent Agenda of routine action items to be considered by one motion. Items pass unanimously unless a separate roll call vote is requested by a Board Member.

5. Approval of the minutes of the March 14, 2017 meeting
6. Approval of claims
7. County Auditor – Patrick Gill
 - a. Receive Morgan Township Trustee appointment
 - b. Receive Wolf Creek Township Trustee appointment
 - c. Consideration and approval for liquor license for the Anthon Golf Course
 - d. Consideration and approval for liquor license for the Foot Wedge Lounge

8. Board Administration – Karen James
 - a. Approval of resolution approving petition for suspension of taxes through the redemption process for J. P.
 - b. Approval of lifting a tax suspension for J. F.
9. Human Resources – Ed Gilliland
 - a. Approval of Memorandum of Personnel Transactions
 - b. Authorize Chairman to sign Authorization to Initiate Hiring Process

End of Consent Agenda

- | | |
|---|-------------|
| 10. LaunchPAD – Bob Fitch
Update on LaunchPAD Children’s Museum | Information |
| 11. Sioux Rivers Region – Patty Erickson-Puttmann
Consideration and approval of “Stepping Up” Resolution | Action |
| 12. County Auditor – Patrick Gill
Consideration of an amendment to the Board Bylaws | Action |
| 13. Board of Supervisors – Keith Radig
Sale and development of County owned parcels | Information |
| 14. Board of Supervisors – Matthew Ung
Information regarding Radig’s agenda item | Information |
| 15. Chairman’s Report <ol style="list-style-type: none"> a. Iowa League of Cities meeting (March 15) b. FY18 Popular Annual Financial Report c. March Dept. Head Meeting (March 20) d. Consensus to Request Ag Expo Center Update | Information |
| 16. Reports on Committee Meetings | Information |
| 17. Citizen Concerns | Information |
| 18. Board Concerns and Comments | Information |

ADJOURNMENT

Subject to Additions/Deletions

CALENDAR OF EVENTS

MONDAY, MARCH 20	8:00 a.m.	Department Head Meeting
TUESDAY, MARCH 21	2:30 p.m.	Health & Wellness Committee, 8 th Floor Courthouse
THURSDAY, MARCH 23	9:30 a.m.	SIMPCO SRTPA Policy Meeting, 1122 Pierce St., Sioux City, Iowa
	10:30 a.m.	Siouxland Regional Transit System, 1122 Pierce St., Sioux City, Iowa
	12:00 noon	SIMPCO Housing Trust Fund, 1122 Pierce St., Sioux City, Iowa
MONDAY, MARCH 27	6:30 p.m.	Correctionville Town Hall Meeting, Correctionville Community Center
TUESDAY, MARCH 28	1:30 p.m.	Sioux Rivers Regional Governance Board Meeting, Plymouth County Courthouse Annex Building, 215 4th Ave. S.E., Le Mars, Iowa
	2:00 p.m.	Decat Board Meeting, Western Hills AEA, Room F
MONDAY, APRIL 3	6:00 p.m.	Board of Adjustment meeting, Board of Supervisors' Chambers
TUESDAY, APRIL 4	10:00 a.m.	Policy Review Committee Meeting, First Floor Board of Supervisors Meeting Room
	2:30 p.m.	Woodbury County Courthouse Advisory Committee for Historical Preservation, First Floor Board of Supervisors Meeting Room
	4:45 p.m.	Veteran Affairs Meeting, Veteran Affairs Office, 1211 Tri-View Ave.
WEDNESDAY, APRIL 5	12:00 noon	District Board of Health Meeting, 1014 Nebraska St.
THURSDAY, APRIL 6	4:30 p.m.	Conservation Board Meeting, Dorothy Pecaut Nature Center, Stone Park
WEDNESDAY, APRIL 12	8:05 a.m.	Woodbury County Information Communication Commission, Board of Supervisors' Chambers

The following Boards/Commission have vacancies: Commission to Assess Damages - Category A, Category B, Category C and Category D

Community Action Agency of Siouxland Board of Directors has one vacancy

Woodbury County is an Equal Opportunity Employer. In compliance with the Americans with Disabilities Act, the County will consider reasonable accommodations for qualified individuals with disabilities and encourages prospective employees and incumbents to discuss potential accommodations with the Employer.

Federal and state laws prohibit employment and/or public accommodation discrimination on the basis of age, color, creed, disability, gender identity, national origin, pregnancy, race, religion, sex, sexual orientation or veteran's status. If you believe you have been discriminated against, please contact the Iowa Civil Rights Commission at 800-457-4416 or Iowa Department of Transportation's civil rights coordinator. If you need accommodations because of a disability to access the Iowa Department of Transportation's services, contact the agency's affirmative action officer at 800-262-0003.

MARCH 14, 2017, ELEVENTH MEETING OF THE WOODBURY COUNTY BOARD OF SUPERVISORS

The Board of Supervisors met on Tuesday, March 14, 2017 at 4:30 p.m. Board members present were Ung, De Witt, Radig, Taylor, and Pottebaum. Staff members present were Dennis Butler, Budget/Tax Analyst, Karen James, Board Administrative Coordinator, Ed Gilliland, Human Resources Director, Abigail Sills, Assistant County Attorney and Patrick Gill, Auditor/Clerk to the Board.

- 1. The meeting was called to order with the Pledge of Allegiance to the Flag and a Moment of Silence.
- 2. Citizen concerns.
- 3. Motion by Ung second by Taylor to approve the Agenda for March 14, 2017. Carried 5-0. Copy filed.

Motion by Radig second by Pottebaum to approve the following items by consent:

- 4. To approve minutes of the March 7, 2017 meeting. Copy filed.
- 5. To approve the claims totaling \$557,488.72. Copy filed.
- 6a. To approve the promotion of Toni Haefs, Senior Clerk, County Sheriff Dept., effective 03-15-17, \$17.94/hour, 14%=\$2.30/hr. Promotion from Clerk II to Senior Clerk.; the reclassification of Tonia Abell, Senior Clerk, Human Resources Dept., effective 03-28-17, \$18.62/hour, 4%=\$.68/hr. Per Wage Plan comparability with AFSCME Courthouse Contract, from Grade 4/Step 2 to Grade 4/Step 3.; and the reclassification of David Hansen, Sheriff Deputy, County Sheriff Dept., effective 04-01-17, \$27.73/hour, 6%=\$1.69/hour. Per CWA Deputy Sheriff Contract agreement, from Class I to Senior Class due to 4 years employment and Bachelor’s Degree. Copy filed.
- 6b. To approve and authorize the Chairperson to sign the Authorization to initiate the hiring process for Temporary Summer Laborers (5), Secondary Roads Dept., Wage Plan: \$9.00-\$11.00/hour. and for Temporary Engineering Aides (3), Secondary Roads Dept., Wage Plan: \$11.00-\$14.00/hour. Copy filed.
- 7. To receive the award of \$1,650.00 from MidAmerican Energy Local Partners Grant Program. Copy filed.

Carried 5-0.

- 8. A public hearing was held at 4:35 p.m. for the sale of parcel #536161, 3099 Transit Ave. The Chairperson called on anyone wishing to be heard.

Motion by Taylor second by Radig to close the public hearing. Carried 5-0.

Motion by Taylor second by Ung to approve and authorize the Chairperson to sign a Resolution for the sale of this parcel to Shay Hacker, 2910 Garretson Ave., Sioux City, IA, for real estate parcel #536161, 3099 Transit Ave, for \$606.00 plus recording fees. Carried 5-0.

**RESOLUTION OF THE BOARD
OF SUPERVISORS OF WOODBURY COUNTY, IOWA
RESOLUTION #12,509**

BE IT RESOLVED by the Board of Supervisors of Woodbury County, Iowa, that the offer at public auction of:

By Shay Patrick Hacker in the sum of **Six Hundred Six Dollars & 00/100 (\$606.00)**-----
-----dollars.

For the following described real estate, To Wit:

Parcel #536161

West 66 feet North 12.45 feet of Lot 1 and Triangle Tract in Northerly and Westerly part of Lot 2 in Block 60 West Morningside Addition, City of Sioux City, Woodbury County, Iowa (3099 Transit Avenue)

Now and included in and forming a part of the City of Sioux City, Iowa, the same is hereby accepted: said Amount being a sum LESS than the amount of the general taxes, interests, costs and penalties against the said Real Estate.

BE IT RESOLVED that payment is due by close of business on the day of passage of this resolution or this sale is null and void and this resolution shall be rescinded.

BE IT RESOLVED that per Code of Iowa Section 569.8(3 & 4), a parcel the County holds by tax deed shall not be assessed or taxed until transferred and upon transfer of a parcel so acquired gives the purchaser free title as to previously levied or set taxes. Therefore, the County Treasurer is requested to abate any taxes previously levied or set on this parcel(s).

BE IT FURTHER RESOLVED that the Chairman of this Board be and he is hereby authorized to execute a Quit Claim Deed for the said premises to the said purchaser.

SO DATED this 14th Day of March, 2017.
WOODBURY COUNTY BOARD OF SUPERVISORS
Copy filed.

9. Motion by Taylor second by Ung to approve the funding in the amount of \$15,000.00 from local option sales tax proceeds for the Local Housing Trust Fund for FY 2017/2018. Carried 5-0. Copy filed.
10. A public hearing was held at 4:45 p.m. for tower lease with Motorola Solutions, Inc. within the WIT Tower site.
Motion by Taylor second by Radig to close the public hearing. Carried 5-0.
Motion by Taylor second by Radig to approve a tower lease with Motorola Solutions, Inc. for an initial term of thirteen (13) years between Woodbury County, Starcomm, the City of Sioux City, and Motorola Solutions, Inc. for Starcomm WIT Tower at 4647 Stone Ave. Carried 5-0. Copy filed.
11. Motion by Ung second by Radig to receive the Woodbury County's Certified Annual Financial Report for FY 2016. Carried 5-0. Copy filed.
12. The Chairperson reported on the day-to-day activities.
13. The Board members reported on their committee meetings.
14. Citizen concerns.
15. Board members presented their concerns and comments.

The Board adjourned the regular meeting until March 21, 2017.

Meeting sign in sheet. Copy filed.

WOODBURY COUNTY
SIOUX CITY, IOWA 51101

Office of Commissioner of Elections

620 DOUGLAS ST., ROOM 103



Patrick F. Gill
Commissioner
Phone 712-279-6465
Fax 712-279-6629
pgill@woodburycountyiowa.gov

Steve Hofmeyer
Deputy Commissioner
Phone 712-279-6465
Fax 712-279-6629
shofmeyer@woodburycountyiowa.gov

To: Board of Supervisors

From: Patrick F. Gill, Auditor/Recorder & Commissioner of Elections

Date: March 14, 2017

Re: Morgan Township Trustee Appointment

Please receive the appointment of Kurt Heinse, 4467 250th Street, Danbury, Iowa, as a Trustee for Morgan Township, until the next regular election. The appointment was made on March 7, 2017, to fill the position previously held by Claire Welte.

NOTICE OF APPOINTMENT TO FILL A VACANCY

TO: Patrick F. Gill, Woodbury County Auditor/Recorder & Commissioner of Elections

From: Morgan School/City/Township/
Lance J. Hamann Extension/Soil & Water
3/7/17 Secretary/Clerk
Date

This is to notify you and the Board of Supervisors of Woodbury County that the following person has been appointed until the next regular/general election:

For the office of Trustee Morgan Township
Name Kurt Heinse
Address 4467 250th St.
City/Zip Danbury Ia. 51019

This appointment is to fill the office previously held by:

Claire Welte
(Name of previous official)

PATRICK F. GILL
WOODBURY COUNTY
2017 MAR 13 AM 10 48
AUDITOR RECORDER
COMM. OF ELECTIONS

WOODBURY COUNTY
SIOUX CITY, IOWA 51101

#7b

Office of Commissioner of Elections

620 DOUGLAS ST., ROOM 103

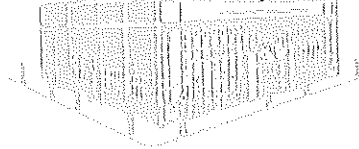

Patrick F. Gill
Commissioner
Phone 712-279-6465
Fax 712-279-6629
pgill@woodburycountyiowa.gov

Steve Hofmeyer
Deputy Commissioner
Phone 712-279-6465
Fax 712-279-6629
shofmeyer@woodburycountyiowa.gov

To: Board of Supervisors

From: Patrick F. Gill, Auditor/Recorder & Commissioner of Elections

Date: March 15, 2017

Re: Wolf Creek Township Trustee Appointment

Please receive the appointment of Roger Wilson, 1610 Jasper Avenue, Merville, Iowa, as Trustee for Wolf Creek Township, until the next regular election. The appointment was made on March 15, 2017, to fill a vacant position.

NOTICE OF APPOINTMENT TO FILL A VACANCY

TO: Patrick F. Gill, Woodbury County Auditor/Recorder & Commissioner of Elections

From: Wolf Creek Township Clerk School/City/Township/
Dawn Wilcox Dawn Wilcox Extension/Soil & Water
15MB17 Secretary/Clerk
Date

This is to notify you and the Board of Supervisors of Woodbury County that the following person has been appointed until the next regular/general election:

For the office of Township Trustee
Name Roger Wilson
Address 1610 Jasper Ave.
City/Zip Monville, IA 51039

This appointment is to fill the office previously held by:

(Name of previous official)

WOODBURY COUNTY BOARD OF SUPERVISORS AGENDA ITEM(S) REQUEST FORM

Date: 03/16/2017 Weekly Agenda Date: 03/21/2017

ELECTED OFFICIAL / DEPARTMENT HEAD / CITIZEN: County Auditor - Pat Gill

WORDING FOR AGENDA ITEM:

Consideration and approval for liquor license for the Anthon Golf Course

ACTION REQUIRED:

- Approve Ordinance
- Approve Resolution
- Approve Motion
- Public Hearing
- Other: Informational
- Attachments

EXECUTIVE SUMMARY:

n/a

BACKGROUND:

n/a

FINANCIAL IMPACT:

Unknown at this time

IF THERE IS A CONTRACT INVOLVED IN THE AGENDA ITEM, HAS THE CONTRACT BEEN SUBMITTED AT LEAST ONE WEEK PRIOR AND ANSWERED WITH A REVIEW BY THE COUNTY ATTORNEY'S OFFICE?

- Yes
- No

RECOMMENDATION:

Approve Motion

ACTION REQUIRED / PROPOSED MOTION:

Motion to approve an application for an 8-month, Class C Liquor License with Outdoor Service and Sunday sales for the Anthon Golf Course, effective 04/01/2017 through 03/31/2018.

**Office Of The
AUDITOR/RECORDER
Of Woodbury County**

PATRICK F. GILL
Auditor/Recorder

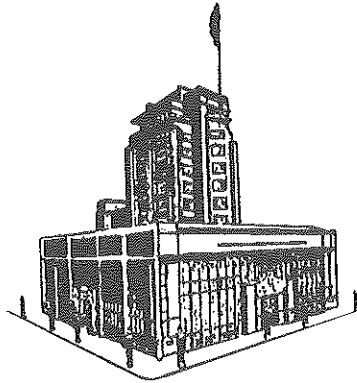

**Court House – Rooms 103
620 Douglas
Sioux City, Iowa 51101**

**Phone (712) 279-6702
Fax (712) 279-6629**

To: Board of Supervisors

From: Patrick F. Gill, Auditor & Recorder

MKS

Date: March 16, 2017

Subject: Liquor License Application for the Anthon Golf Course

Please approve an applicaton for a 12-month, Class C
Liquor License with with Outdoor Service and Sunday sales privileges, for
the Anthon Golf Course, 2236 Hwy 31 South, Anthon, Iowa. The permit would
be effective 04/01/17 through 03/31/18.

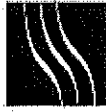

State of Iowa
**ALCOHOLIC
BEVERAGES DIVISION**

- About
- Alcohol
- Tobacco
- Links
- Contact

- [Help](#)
- [License Search](#)
- [License List](#)
- [On-Demand Reporting](#)
- [Keg Registration Search](#)
- [User Profile](#)
- [Logoff](#)

- » License
- » Privileges
- » Applicant
- » Status Of Business
- » Ownership - Names
- » Ownership - Interests
- » Criminal History
- » Premises
- » General Premises
- » Applicant Signature
- » Dram Cert
- » Local Endorse
- » History

Applicant License LC0037482, Anthon Golf Course, Anthon

After completion click on the NEXT link to continue to the next screen, or the BACK link to return to the previous screen.

The navigation links on the top may also be used to move around the application.

LENGTH OF LICENSE REQUESTED:
(Choose one of the following):

12 month

8 month

6 month

14 day

5 day

License Status: Submitted to Local Authority

Original issue date of license: MM/DD/YYYY

Issue date of current license: MM/DD/YYYY

License effective date: MM/DD/YYYY

License expiration date: MM/DD/YYYY

Number of days notice:

70 day notice:

Cancel date: MM/DD/YYYY

[Prev](#)

[Next](#)

Follow us with RSS, Facebook or Twitter



Contact Us

Iowa Alcoholic Beverages Division
1918 SE Hulsizer Road, Ankeny, IA 50021
Toll Free 866.IowaABD (866.469.2223)
Local 515.281.7400

- [Terms and Conditions](#)
- [Privacy Policy](#)

Copyright ©2009 State of Iowa
Alcoholic Beverages Division. All Rights Reserved.



State of Iowa
**ALCOHOLIC
BEVERAGES DIVISION**

- About
- Alcohol
- Tobacco
- Links
- Contact

-
-
-
-
-

Help	License Search	License List	On-Demand Reporting	Keg Registration Search	User Profile	Logoff
----------------------	--------------------------------	------------------------------	-------------------------------------	---	------------------------------	------------------------

Privileges LC0037482, Anthon Golf Course, Anthon

- » License
- » Privileges
- » Applicant
- » Status Of Business
- » Ownership - Names
- » Ownership - Interests
- » Criminal History
- » Premises
- » General Premises
- » Applicant Signature
- » Dram Cert
- » Local Endorse
- » History

After completion click on the NEXT link to continue to the next screen, or the BACK link to return to the previous screen.

The navigation links on the top may also be used to move around the application.

Select one or more of the privileges you wish to have for your Class C Liquor License (LC) (Commercial). If no privileges are applicable please leave all boxes unchecked and hit the next button.

PRIVILEGES:

- Brew Pub
- Catering Privilege
- Class B Native Wine Permit
- Class B Wine Permit (Carryout Wine - Includes Native Wine)
- High Proof Brew Pub
- Living Quarters
- Outdoor Service
- Sunday Sales

[Prev](#)

[Next](#)

Follow us with RSS, Facebook or Twitter



Contact Us

Iowa Alcoholic Beverages Division
1918 SE Hulsizer Road, Ankeny, IA 50021
Toll Free 866.IowaABD (866.469.2223)
Local 515.281.7400

- Terms and Conditions
- Privacy Policy

Copyright ©2009 State of Iowa
Alcoholic Beverages Division. All Rights Reserved.



- Help
- License Search
- License List
- On-Demand Reporting
- Keg Registration Search
- User Profile
- Logoff

- > License
- > Privileges
- > Applicant
- > Status Of Business
- > Ownership - Names
- > Ownership - Interests
- > Criminal History
- > Premises
- > General Premises
- > Applicant Signature
- > Dram Cart
- > Local Endorse
- > History

Applicant LC0037482, Anthon Golf Course, Anthon

After completion click on the NEXT link to continue to the next screen, or the BACK link to return to the previous screen. The navigation links on the top may also be used to move around the application.

Corporation Name/Sole Proprietor Name/Partnership Name(s): (Sole Proprietorship, Partnership, Corporation, etc.)

Name of Business (D/B/A):

Address of Premise:

Address Line 2:

City:

County:

Zip:

Business Phone: Cell / Home Phone:

Same Address

Mailing Address:

Mailing Address Line 2:

City: State:

Zip:

Contact Name:

Phone: Email Address:

[Prev](#)

[Next](#)

Follow us with RSS, Facebook or Twitter



Contact Us

Iowa Alcoholic Beverages Division
 1918 SE Hulsizer Road, Ankeny, IA 50021
 Toll Free 866.IowaABD (866.469.2223)
 Local 515.281.7400

[Terms and Conditions](#)
[Privacy Policy](#)

Copyright ©2009 State of Iowa
 Alcoholic Beverages Division, All Rights Reserved.

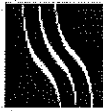

State of Iowa
**ALCOHOLIC
BEVERAGES DIVISION**

- About
- Alcohol
- Tobacco
- Links
- Contact

-
-
-
-
-

- Help
- License Search
- License List
- On-Demand Reporting
- Keg Registration Search
- User Profile
- Logoff

Status of Business LC0037482, Anthon Golf Course, Anthon



After completion click on the NEXT link to continue to the next screen, or the BACK link to return to the previous screen.
The navigation links on the top may also be used to move around the application.

- License
- Privileges
- Applicant
- Status Of Business
- Ownership - Names
- Ownership - Interests
- Criminal History
- Premises
- General Premises
- Applicant Signature
- Dram Cert
- Local Endorse
- History

Indicate how the business will be operated (Choose one of the following):

<input type="radio"/> Sole Proprietorship	<input type="radio"/> Publicly Traded Corporation
<input type="radio"/> General Partnership	<input type="radio"/> Limited Liability Company
<input type="radio"/> Limited Partnership	<input type="radio"/> Municipality
<input checked="" type="radio"/> Privately-Held Corporation	<input type="radio"/> Non-Profit Association

Corporate ID Number: 167412 Federal Employer ID#: 42-1406936

Federal Employer ID Applied For:

Prev

Next

Follow us with RSS, Facebook or Twitter



Contact Us

Iowa Alcoholic Beverages Division
1918 SE Hulsizer Road, Ankeny, IA 50021
Toll Free 866.IowaABD (866.469.2223)
Local 515.281.7400

- Terms and Conditions
- Privacy Policy

Copyright ©2009 State of Iowa
Alcoholic Beverages Division. All Rights Reserved.



State of Iowa
ALCOHOLIC
BEVERAGES DIVISION

- About
- Alcohol
- Tobacco
- Links
- Contact

- Help
- License Search
- License List
- On-Demand Reporting
- Keg Registration Search
- User Profile
- Logoff

Ownership LC0037482, Anthon Golf Course, Anthon

- > License
- > Privileges
- > Applicant
- > Status Of Business
- > Ownership - Names
- > Ownership - Interests
- > Criminal History
- > Premises
- > General Premises
- > Applicant Signature
- > Dram Cert
- > Local Endorse
- > History

After completion click on the NEXT link to continue to the next screen, or the BACK link to return to the previous screen. The navigation links on the top may also be used to move around the application.

Corporate applicant's, list all shareholders having 10% or more interest in the corporation and all officers and directors of the corporation regardless of ownership interest. Sole Proprietors shall also include their spouse even if the spouse owns 0% interest. Non-profit corporations or associations need to list officers. Partnerships and Committees not registered with the Secretary of State office will need a trade name filing from their county recorder's office.

If you want to change ownership information at renewal time please finish the renewal with the current ownership listed. When you are finished please go to the Action List and submit an Ownership Update Application along with the license renewal.

Owners:

Name	Address	Percentage	
Anthony Collins	403 S. 1st Avenue, Anthon, IA, 51004	0.00 %	View
keith schrunk	3846 245th Street, Anthon, IA, 51004	0.00 %	View
nancy oconnell	2290 obrien ave, anthon, IA, 51004	0.00 %	View

First Name: Last Name:
 Address:
 Address Line 2:
 City: State:
 Zip:
 Position: SS#: U.S. Citizen:
 Date of Birth: MM/DD/YYYY % of Ownership:

Please make sure you press "Add" after each owner's information is listed above before pushing the next button.

Follow us with RSS, Facebook or Twitter



Contact Us

Iowa Alcoholic Beverages Division
1918 SE Hulsizer Road, Ankeny, IA 50021
Toll Free 866.IowaABD (866.469.2223)
Local 515.281.7400

- Terms and Conditions
- Privacy Policy

Copyright ©2009 State of Iowa
Alcoholic Beverages Division. All Rights Reserved.

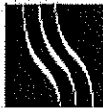

State of Iowa
**ALCOHOLIC
BEVERAGES DIVISION**

- About
- Alcohol
- Tobacco
- Links
- Contact

Help	License Search	License List	On-Demand Reporting	Keg Registration Search	User Profile	Logoff
----------------------	--------------------------------	------------------------------	-------------------------------------	---	------------------------------	------------------------

- » License
- » Privileges
- » Applicant
- » Status Of Business
- » Ownership - Names
- » Ownership - Interests
- » Criminal History
- » Premises
- » General Premises
- » Applicant Signature
- » Dram Cert
- » Local Endorse
- » History

Ownership Interests LC0037482, Anthon Golf Course, Anthon

After completion click on the NEXT link to continue to the next screen, or the BACK link to return to the previous screen.

The navigation links on the top may also be used to move around the application.

The following questions apply to the applicant and all persons and entities listed in the "Ownership - Names" section. The term "interest" means engaged in the ownership, conduct, or operation. Please direct any questions to info@iowaabd.com.

Question 1 of 6: Do you or any of your employees, agents, jobbers, representatives, directors, or officers have a direct or indirect interest in any liquor, wine or beer manufacturer, bottler, importer, wholesaler or broker in Iowa, the United States or outside the United States?

YES - PROVIDE THE FOLLOWING

NO

Prev

Next

Follow us with RSS, Facebook or Twitter



Contact Us

Iowa Alcoholic Beverages Division
1918 SE Hulsizer Road, Ankeny, IA 50021
Toll Free 866.IowaABD (866.469.2223)
Local 515.281.7400

- Terms and Conditions
- Privacy Policy

Copyright ©2009 State of Iowa
Alcoholic Beverages Division. All Rights Reserved.

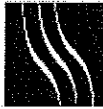

State of Iowa
**ALCOHOLIC
BEVERAGES DIVISION**

- About
- Alcohol
- Tobacco
- Links
- Contact

Help	License Search	License List	On-Demand Reporting	Keg Registration Search	User Profile	Logoff
------	----------------	--------------	---------------------	-------------------------	--------------	--------

- License
- Privileges
- Applicant
- Status Of Business
- Ownership - Names
- Ownership - Interests
- Criminal History
- Premises
- General Premises
- Applicant Signature
- Dram Cert
- Local Endorse
- History

Ownership Interests LC0037482, Anthon Golf Course, Anthon

After completion click on the NEXT link to continue to the next screen, or the BACK link to return to the previous screen.

The navigation links on the top may also be used to move around the application.

The following questions apply to the applicant and all persons and entities listed in the "Ownership - Names" section. The term "interest" means engaged in the ownership, conduct, or operation. Please direct any questions to info@iowaabd.com.

Question 2 of 6: Does any liquor, wine or beer manufacturer, bottler, importer, wholesaler or broker in Iowa, the United States or outside the United States have a direct or indirect interest in your business?

YES - PROVIDE THE FOLLOWING

NO

Prev

Next

Follow us with RSS, Facebook or Twitter



Contact Us

Iowa Alcoholic Beverages Division
1918 SE Hulsizer Road, Ankeny, IA 50021
Toll Free 866.IowaABD (866.469.2223)
Local 515.281.7400

- Terms and Conditions
- Privacy Policy

Copyright ©2009 State of Iowa
Alcoholic Beverages Division. All Rights Reserved.

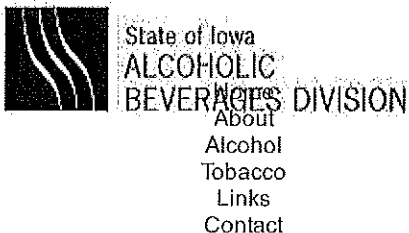

-
-
-
-
-
-

Help	License Search	License List	On-Demand Reporting	Keg Registration Search	User Profile	Logoff
------	----------------	--------------	---------------------	-------------------------	--------------	--------

- » License
- » Privileges
- » Applicant
- » Status Of Business
- » Ownership - Names
- » Ownership - Interests
- » Criminal History
- » Premises
- » General Premises
- » Applicant Signature
- » Dram Cert
- » Local Endorse
- » History

Ownership Interests LC0037482, Anthon Golf Course, Anthon

After completion click on the NEXT link to continue to the next screen, or the BACK link to return to the previous screen.

The navigation links on the top may also be used to move around the application.

The following questions apply to the applicant and all persons and entities listed in the "Ownership - Names" section. The term "interest" means engaged in the ownership, conduct, or operation. Please direct any questions to info@iowaabd.com.

Question 3 of 6: Has any liquor, wine or beer manufacturer, bottler, importer, wholesaler or broker in Iowa, the United States or outside the United States paid all or part of your license fee?

YES - PROVIDE THE FOLLOWING

NO

Prev

Next

Follow us with RSS, Facebook or Twitter



Contact Us

Iowa Alcoholic Beverages Division
1918 SE Hulsizer Road, Ankeny, IA 50021
Toll Free 866.IowaABD (866.469.2223)
Local 515.281.7400

-
-

Terms and Conditions
Privacy Policy

Copyright ©2009 State of Iowa
Alcoholic Beverages Division. All Rights Reserved.

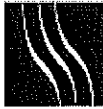

State of Iowa
**ALCOHOLIC
BEVERAGES DIVISION**

- About
- Alcohol
- Tobacco
- Links
- Contact

Help	License Search	License List	On-Demand Reporting	Keg Registration Search	User Profile	Logoff
------	----------------	--------------	---------------------	-------------------------	--------------	--------

- License
- Privileges
- Applicant
- Status Of Business
- Ownership - Names
- Ownership - Interests
- Criminal History
- Premises
- General Premises
- Applicant Signature
- Dram Cert
- Local Endorse
- History

Ownership Interests LC0037482, Anthon Golf Course, Anthon

After completion click on the NEXT link to continue to the next screen, or the BACK link to return to the previous screen.
The navigation links on the top may also be used to move around the application.

The following questions apply to the applicant and all persons and entities listed in the "Ownership - Names" section. The term "interest" means engaged in the ownership, conduct, or operation. Please direct any questions to info@iowaabd.com.

Question 4 of 6: Has any liquor, wine or beer manufacturer, bottler, importer, wholesaler or broker in Iowa, the United States or outside the United States provided any loan, credit, money, gift or equivalent to you?

YES - PROVIDE THE FOLLOWING

NO

Prev

Next

Follow us with RSS, Facebook or Twitter



Contact Us

Iowa Alcoholic Beverages Division
1918 SE Hulsizer Road, Ankeny, IA 50021
Toll Free 866.IowaABD (866.469.2223)
Local 515.281.7400

- Terms and Conditions
- Privacy Policy

Copyright ©2009 State of Iowa
Alcoholic Beverages Division. All Rights Reserved.

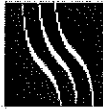

State of Iowa
ALCOHOLIC BEVERAGES DIVISION
 About
 Alcohol
 Tobacco
 Links
 Contact

-
-
-
-
-
-

Help	License Search	License List	On-Demand Reporting	Keg Registration Search	User Profile	Logoff
------	----------------	--------------	---------------------	-------------------------	--------------	--------

- » License
- » Privileges
- » Applicant
- » Status Of Business
- » Ownership - Names
- » Ownership - Interests
- » Criminal History
- » Premises
- » General Premises
- » Applicant Signature
- » Dram Cert
- » Local Endorse
- » History

Ownership Interests LC0037482, Anthon Golf Course, Anthon

After completion click on the NEXT link to continue to the next screen, or the BACK link to return to the previous screen.
 The navigation links on the top may also be used to move around the application.

The following questions apply to the applicant and all persons and entities listed in the "Ownership - Names" section. The term "interest" means engaged in the ownership, conduct, or operation. Please direct any questions to info@iowaabd.com.

Question 5 of 6: Does any liquor, wine or beer manufacturer, bottler, importer, wholesaler or broker in Iowa, the United States or outside the United States own or have an interest in your furnishings, fixtures, or equipment?

YES - PROVIDE THE FOLLOWING

NO

Prev

Next

Follow us with RSS, Facebook or Twitter



Contact Us

Iowa Alcoholic Beverages Division
 1918 SE Hulsizer Road, Ankeny, IA 50021
 Toll Free 866.IowaABD (866.469.2223)
 Local 515.281.7400

-
-

Terms and Conditions
 Privacy Policy

Copyright ©2009 State of Iowa
 Alcoholic Beverages Division. All Rights Reserved.

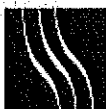

State of Iowa
**ALCOHOLIC
BEVERAGES DIVISION**

- About
- Alcohol
- Tobacco
- Links
- Contact

Help	License Search	License List	On-Demand Reporting	Keg Registration Search	User Profile	Logoff
------	----------------	--------------	---------------------	-------------------------	--------------	--------

- » License
- » Privileges
- » Applicant
- » Status Of Business
- » Ownership - Names
- » Ownership - Interests
- » Criminal History
- » Premises
- » General Premises
- » Applicant Signature
- » Dram Cert
- » Local Endorse
- » History

Ownership Interests LC0037482, Anthon Golf Course, Anthon

After completion click on the NEXT link to continue to the next screen, or the BACK link to return to the previous screen.

The navigation links on the top may also be used to move around the application.

The following questions apply to the applicant and all persons and entities listed in the "Ownership - Names" section. The term "interest" means engaged in the ownership, conduct, or operation. Please direct any questions to info@iowaabd.com.

Question 6 of 6: Are you or any of your employees, agents, jobbers, representatives, directors or officers also employed by any liquor, wine or beer manufacturer, bottler, importer, wholesaler or broker in Iowa, the United States or outside the United States?

YES - PROVIDE THE FOLLOWING

NO

Prev

Next

Follow us with RSS, Facebook or Twitter



Contact Us

Iowa Alcoholic Beverages Division
1918 SE Hulsizer Road, Ankeny, IA 50021
Toll Free 866.IowaABD (866.469.2223)
Local 515.281.7400

- Terms and Conditions
- Privacy Policy

Copyright ©2009 State of Iowa
Alcoholic Beverages Division. All Rights Reserved.

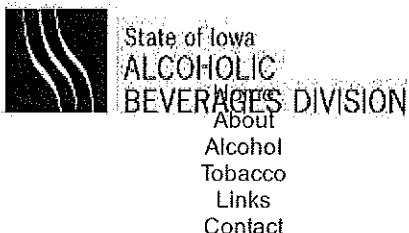

-
-
-
-
-
-

Help	License Search	License List	On-Demand Reporting	Keg Registration Search	User Profile	Logoff
------	----------------	--------------	---------------------	-------------------------	--------------	--------

- License
- Privileges
- Applicant
- Status Of Business
- Ownership - Names
- Ownership - Interests
- Criminal History
- Premises
- General Premises
- Applicant Signature
- Dram Cert
- Local Endorse
- History

Criminal History LC0037482, Anthon Golf Course, Anthon

After completion click on the NEXT link to continue to the next screen, or the BACK link to return to the previous screen.

The navigation links on the top may also be used to move around the application.

<input type="text" value="No"/>	Since this license was last issued, has anyone listed in the ownership screen been convicted of a felony offense in Iowa or any other state of the United States? If yes, list on the next (Violations) screen.
<input type="text" value="No"/>	Since the license was last issued, have any of the owners listed in the ownership screen been charged, arrested, indicted, convicted or received a deferred judgment for any violation of any state, county, city, federal or foreign law? All information shall be reported regardless of the disposition, even if dismissed or expunged. Include pending charges. DO NOT include traffic violations, except those that are alcohol related. If yes, list violations on the next (Violations) screen.
<input type="text" value="None"/>	If no arrests, indictments, summons or convictions are applicable since the license was last issued, select 'NONE'.

[⏪ Pre](#)

[Next ⏩](#)

Follow us with RSS, Facebook or Twitter



Contact Us

Iowa Alcoholic Beverages Division
1918 SE Hulsizer Road, Ankeny, IA 50021
Toll Free 866.IowaABD (866.469.2223)
Local 515.281.7400

-
-

[Terms and Conditions](#)
[Privacy Policy](#)

Copyright ©2009 State of Iowa
Alcoholic Beverages Division. All Rights Reserved.

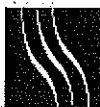

State of Iowa
**ALCOHOLIC
BEVERAGES DIVISION**

- About
- Alcohol
- Tobacco
- Links
- Contact

-
-
-
-
-
-

- [Help](#)
- [License Search](#)
- [License List](#)
- [On-Demand Reporting](#)
- [Keg Registration Search](#)
- [User Profile](#)
- [Logoff](#)

- [License](#)
- [Privileges](#)
- [Applicant](#)
- [Status Of Business](#)
- [Ownership - Names](#)
- [Ownership - Interests](#)
- [Criminal History](#)
- [Premises](#)
- [General Premises](#)
- [Applicant Signature](#)
- [Dram Cert](#)
- [Local Endorse](#)
- [History](#)

Premises Information LC0037482, Anthon Golf Course, Anthon

After completion click on the NEXT link to continue to the next screen, or the BACK link to return to the previous screen.
The navigation links on the top may also be used to move around the application.

Has the premises configuration changed since last year?

Control of premises:

Own

Lease

Other

explain:

Premises type:

Local Authority:

License City:

City Population: 565

License County:

County Population: 102172

Dram Shop:

[Prev](#)

[Next](#)

Follow us with RSS, Facebook or Twitter



Contact Us

Iowa Alcoholic Beverages Division
1918 SE Hulsizer Road, Ankeny, IA 50021
Toll Free 866.IowaABD (866.469.2223)
Local 515.281.7400

- [Terms and Conditions](#)
- [Privacy Policy](#)

Copyright ©2009 State of Iowa
Alcoholic Beverages Division. All Rights Reserved.

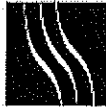

State of Iowa
ALCOHOLIC BEVERAGES DIVISION

- About
- Alcohol
- Tobacco
- Links
- Contact

Help	License Search	License List	On-Demand Reporting	Keg Registration Search	User Profile	Logoff
----------------------	--------------------------------	------------------------------	-------------------------------------	---	------------------------------	------------------------

- License
- Privileges
- Applicant
- Status Of Business
- Ownership - Names
- Ownership - Interests
- Criminal History
- Premises
- General Premises
- Applicant Signature
- Dram Cert
- Local Endorse
- History

General Premises Information LC0037482, Anthon Golf Course, Anthon

After completion click on the NEXT link to continue to the next screen, or the BACK link to return to the previous screen.

The navigation links on the top may also be used to move around the application.

of Bathrooms:

of Floors:

Equipped with tables and seats to accommodate a minimum of 25?

Are other liquor, wine or beer businesses accessible from the interior of your premises?

Does your premises conform to all local and state health, fire and building laws and regulation?

Is the capacity of your establishment over 200?

Do you charge a cover charge?

If yes, how often?

Infusing [click here for more information](#)

- I will be mixing and storing mixed drinks, cocktails, or infusions prior to a customer placing an order for the beverage.
- I will mix, store, and dispense mixed drinks, cocktails or infusions which are not for immediate consumption in compliance with the requirements and restrictions provided in Iowa Code § 123.49(2)"d"(2) and 185 Iowa Administrative Code § 4.5. I understand that a failure to comply with applicable laws and rules will result in a fine, license suspension, and/or license revocation.
- Agree Disagree
- I will NOT be mixing and storing mixed drinks, cocktails, or infusions prior to a customer placing an order for the beverage.

[Prev](#)

[Next](#)

Follow us with RSS, Facebook or Twitter



Contact Us

Iowa Alcoholic Beverages Division
 1918 SE Hulsizer Road, Ankeny, IA 50021
 Toll Free 866.IowaABD (866.469.2223)
 Local 515.281.7400

[Terms and Conditions](#)

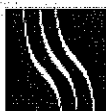

State of Iowa
ALCOHOLIC BEVERAGES DIVISION

- About
- Alcohol
- Tobacco
- Links
- Contact

Help	License Search	License List	On-Demand Reporting	Keg Registration Search	User Profile	Logoff
------	----------------	--------------	---------------------	-------------------------	--------------	--------

- License
- Privileges
- Applicant
- Status Of Business
- Ownership - Names
- Ownership - Interests
- Criminal History
- Premises
- General Premises
- Applicant Signature
- Dram Cert
- Local Endorse
- History

Applicant Signature LC0037482, Anthon Golf Course, Anthon

Complete the information below and click Finish to complete the application
Note that the license fees will only be withdrawn from accounts after the ABD approves the license.

This application must be completed by a person listed in the Ownership Section.

I hereby declare that all information contained in the Application is true and correct. I understand that misrepresentation of material facts in the Application is a crime and grounds for denial of the license or permit under Iowa law. I further understand that, as a condition of receiving a license, the licensed premises is subject to inspection during business hours by appropriate local, state and federal officials.

NOTE: The Applicant's Name must match one of the owner's names from the Ownership screen.

Owner's Signature: Date:
MM/DD/YYYY

Tentative effective date: MM/DD/YYYY

Licensees are required to submit a bi-annual report of shipment to Iowa consumers due January 10th and July 10th for the previous six months of shipment. This report can be found on the "Action List" under "Complete a Tax Report".

Amount to be transferred from your \$ 936.00 account:

Please notify your Financial Institution to allow ACH debits by our agency's ACH ID number, 142-6004553.

Funds will be pulled from your account 2 days after ABD approves the license. You are ready to submit the application for your license to sell alcoholic beverages in the State of Iowa. By providing the bank information requested and clicking on "finish" you are indicating that you are an owner or authorized user of the bank account listed and that you hereby authorize ABD to debit the account in the amount indicated above.

NAME	0123
ADDRESS	01-23456789
CITY, STATE, ZIP	
DATE	
PAY TO THE ORDER OF	\$ <input type="text"/>
BANK NAME	
ADDRESS	
CITY, STATE, ZIP	
FOR	
⑆0123456789⑆ 012345678901234 0123	

Bank Routing Number Bank Account Number Check Number

Applicant's Bank Name:

Applicant's Bank Routing Number: XXXXXXXXXXXXXXXXXXXX

Repeat Bank Routing Number:

The routing number will ALWAYS be 9 digits long. If you are unsure of your routing or account number, call your bank.

Applicant's Account Number: XXXXXXXXXXXXXXXXXXXX

Repeat Account Number:

Credit cards are not accepted. Your bank information is transferred over a secure connection and is completely confidential.

BY CLICKING ON THE "FINISH" BUTTON, I AGREE TO THE TERMS AND CONDITIONS OF USING MY BANK ACCOUNT AS A PAYMENT METHOD, WHICH ARE LISTED BELOW, AND AUTHORIZE THE STATE OF IOWA TO DEBIT MY BANK ACCOUNT FOR THE LICENSING FEE LISTED ABOVE.

~~1. Bank Account Payments. By choosing to use a bank account as your payment method...~~

Please print a copy of this page for your records before clicking the "FINISH" button.

Finish

If you are not taken to a confirmation screen after clicking on "Finish", please see the notes at the top of the applicant signature screen to find out why the application was not submitted.

 [Prev](#)

Follow us with RSS, Facebook or Twitter



Contact Us

Iowa Alcoholic Beverages Division
1918 SE Hulsizer Road, Ankeny, IA 50021
Toll Free 866.IowaABD (866.469.2223)
Local 515.281.7400

[Terms and Conditions](#)
[Privacy Policy](#)

Copyright ©2009 State of Iowa
Alcoholic Beverages Division. All Rights Reserved.

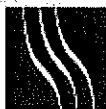

State of Iowa
**ALCOHOLIC
BEVERAGES DIVISION**

- About
- Alcohol
- Tobacco
- Links
- Contact

- Help
- License Search
- License List
- On-Demand Reporting
- Keg Registration Search
- User Profile
- Logoff

- License
- Privileges
- Applicant
- Status Of Business
- Ownership - Names
- Ownership - Interests
- Criminal History
- Premises
- General Premises
- Applicant Signature
- Dram Cert
- Local Endorse
- History

Dram Shop Liability Certificate of Insurance LC0037482, Anthon Golf Course, Anthon

Complete the information below and click **SUBMIT** to endorse this Renewal application.

POLICY INFORMATION	
Reason for re-submittal:	
This is to certify: <i>Scottsdale Insurance Company</i>	
Policy Number:	CPS2615718
Assured:	Anthon Golf Club Inc.
DBA:	Anthon Golf Course
Address:	2236 hwy 31 South
Address Line 2:	
City:	Anthon
State:	Iowa
Zip:	51004
Policy Effective Date:	04/01/2017 MM/DD/YYYY
To: <input checked="" type="radio"/>	Expiration Date: 04/01/2018
Thru: <input type="radio"/>	MM/DD/YYYY

CHECK LIST	
<input checked="" type="checkbox"/>	Outdoor Service Endorsement
<input checked="" type="checkbox"/>	Policy Information Verified (if incorrect please contact the licensee)
Does this policy contain an annual aggregate limit provision?	Yes
If Yes, Annual aggregate limit is:	\$500,000 +

The above-mentioned policy of insurance (hereinafter policy) contains coverage to comply with the provisions of Iowa Code section 123.92 and all regulations of the Iowa Department of Commerce, Alcoholic Beverages Division.

The policy may be canceled by the Company of the Assured giving 30 days notice in writing to the Alcoholic Beverages Division at its office, Ankeny, Iowa. The 30 days notice will commence from the date notice is actually received by the division.

Whenever requested by the division, the company agrees to furnish to the division a duplicate original of the policy and all pertinent endorsements.

Signature: Date: 03/09/2017 MM/DD/YYYY

Submit

Follow us with RSS, Facebook or Twitter



Contact Us



State of Iowa
ALCOHOLIC
BEVERAGES DIVISION
About
Alcohol
Tobacco
Links
Contact

- Help
- License Search
- License List
- On-Demand Reporting
- Keg Registration Search
- User Profile
- Logoff

Local Authority Endorsement LC0037482, Anthon Golf Course, Anthon

- > License
- > Privileges
- > Applicant
- > Status Of Business
- > Ownership - Names
- > Ownership - Interests
- > Criminal History
- > Premises
- > General Premises
- > Applicant Signature
- > Dram Cert
- > Local Endorse
- > History

Complete the information below and click **SUBMIT** to endorse the Renewal.

LICENSE INFORMATION

Local Authority: *County of Woodbury*
 Daytime Phone for Local Authority: (712) 279-6465

License Approved
 License Denied
 License Timely Filed
 Outdoor Service Area Approved
 Outdoor Service Area Denied

Reason For Denial: _____
 Reason For Timely Filing: _____

Effective Date: 04/01/2017 Expiration Date: 03/31/2018

CHECK LIST

Fire inspection completed: Yes No

Health inspection completed Yes No

Was a DCI background check run Yes No

Fee Amount: \$936.00
Local Authority Share: \$390.00

E-MAIL

Please provide the local authority email address below. Once the application has been reviewed and approved, a copy of the license will be emailed to this address.

Local Authority E-mail Address: _____

COMMENTS

Signature: Date: MM/DD/YYYY

Submit

Follow us with RSS, Facebook or Twitter



Contact Us

Iowa Alcoholic Beverages Division
1918 SE Hulsizer Road, Ankeny, IA 50021
Toll Free 866.IowaABD (866.469.2223)
Local 515.281.7400

[Terms and Conditions](#)
[Privacy Policy](#)

Copyright ©2009 State of Iowa
Alcoholic Beverages Division. All Rights Reserved.

WOODBURY COUNTY BOARD OF SUPERVISORS AGENDA ITEM(S) REQUEST FORM

Date: 03/16/2017 Weekly Agenda Date: 03/21/2017

ELECTED OFFICIAL / DEPARTMENT HEAD / CITIZEN: County Auditor - Pat Gill

WORDING FOR AGENDA ITEM:

Consideration and approval for liquor license for the Foot Wedge Lounge

ACTION REQUIRED:

Approve Ordinance Approve Resolution Approve Motion

Public Hearing Other: Informational Attachments

EXECUTIVE SUMMARY:

n/a

BACKGROUND:

n/a

FINANCIAL IMPACT:

Unknown at this time

IF THERE IS A CONTRACT INVOLVED IN THE AGENDA ITEM, HAS THE CONTRACT BEEN SUBMITTED AT LEAST ONE WEEK PRIOR AND ANSWERED WITH A REVIEW BY THE COUNTY ATTORNEY'S OFFICE?

Yes No

RECOMMENDATION:

Approve Motion

ACTION REQUIRED / PROPOSED MOTION:

Motion to approve an application for an 8-month, Class C Liquor License with Outdoor Service and Sunday sales for the Foot Wedge Lounge, effective 03/15/2017 through 11/15/2017.

**Office Of The
AUDITOR/RECORDER
Of Woodbury County**

PATRICK F. GILL
Auditor/Recorder

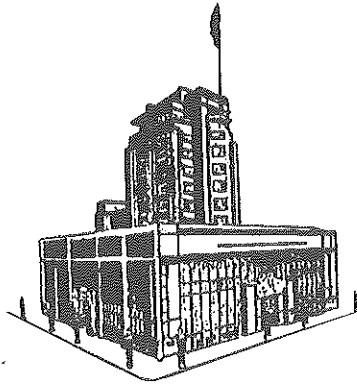

Court House – Rooms 103
620 Douglas
Sioux City, Iowa 51101

Phone (712) 279-6702
Fax (712) 279-6629

To: Board of Supervisors

From: Patrick F. Gill, Auditor & Recorder

MKS

Date: March 16, 2017

Subject: Liquor License Application for the Foot Wedge Lounge

Please approve an applicaton for an 8-month, Class C
Liquor License with with Outdoor Service and Sunday Sales privileges, for
the Foot Wedge Lounge, 3212 Old Highway 75, Sloan, Iowa. The permit would
be effective 03/15/2017 through 11/15/17.



-
-
-
-
-
-

Help	License Search	License List	On-Demand Reporting	Keg Registration Search	User Profile	Logoff
------	----------------	--------------	---------------------	-------------------------	--------------	--------

- License
- Privileges
- Applicant
- Status Of Business
- Ownership - Names
- Ownership - Interests
- Criminal History
- Premises
- General Premises
- Applicant Signature
- Dram Cert
- Local Endorse
- History

Applicant License LC_V_71009, Foot Wedge Lounge, Sloan

After completion click on the NEXT link to continue to the next screen, or the BACK link to return to the previous screen.

The navigation links on the top may also be used to move around the application.

LENGTH OF LICENSE REQUESTED:
(Choose one of the following):

12 month

8 month

6 month

14 day

5 day

License Status: Submitted to Local Authority

Original issue date of license: MM/DD/YYYY

Issue date of current license: MM/DD/YYYY

License effective date: MM/DD/YYYY

License expiration date: MM/DD/YYYY

Number of days notice:

70 day notice:

Cancel date: MM/DD/YYYY

Prev

Next

Follow us with RSS, Facebook or Twitter



Contact Us

Iowa Alcoholic Beverages Division
1918 SE Hulsizer Road, Ankeny, IA 50021
Toll Free 866.IowaABD (866.469.2223)
Local 515.281.7400

-
-

Terms and Conditions
Privacy Policy

Copyright ©2009 State of Iowa
Alcoholic Beverages Division. All Rights Reserved.

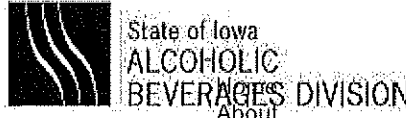

- About
- Alcohol
- Tobacco
- Links
- Contact

- Help
- License Search
- License List
- On-Demand Reporting
- Keg Registration Search
- User Profile
- Logoff

- » License
- » Privileges
- » Applicant
- » Status Of Business
- » Ownership - Names
- » Ownership - Interests
- » Criminal History
- » Premises
- » General Premises
- » Applicant Signature
- » Dram Cert
- » Local Endorse
- » History

Privileges LC_V_71009, Foot Wedge Lounge, Sloan

After completion click on the NEXT link to continue to the next screen, or the BACK link to return to the previous screen.

The navigation links on the top may also be used to move around the application.

Select one or more of the privileges you wish to have for your Class C Liquor License (LC) (Commercial). If no privileges are applicable please leave all boxes unchecked and hit the next button.

PRIVILEGES:

- Brew Pub
- Class B Native Wine Permit
- Class B Wine Permit (Carryout Wine - Includes Native Wine)
- High Proof Brew Pub
- Living Quarters
- Outdoor Service
- Sunday Sales

[Prev](#)

[Next](#)

Follow us with RSS, Facebook or Twitter



Contact Us

Iowa Alcoholic Beverages Division
 1918 SE Hulsizer Road, Ankeny, IA 50021
 Toll Free 866.IowaABD (866.469.2223)
 Local 515.281.7400

- Terms and Conditions
- Privacy Policy

Copyright ©2009 State of Iowa
 Alcoholic Beverages Division. All Rights Reserved.



- Help
- License Search
- License List
- On-Demand Reporting
- Keg Registration Search
- User Profile
- Logoff

- License
- Privileges
- Applicant
- Status Of Business
- Ownership - Names
- Ownership - Interests
- Criminal History
- Premises
- General Premises
- Applicant Signature
- Dram Cert
- Local Endorse
- History

Applicant LC_V_71009, Foot Wedge Lounge, Sloan

After completion click on the NEXT link to continue to the next screen, or the BACK link to return to the previous screen. The navigation links on the top may also be used to move around the application.

Corporation Name/Sole Proprietor Name/Partnership Name(s): Sloan Community Recreation Corp (Sole Proprietorship, Partnership, Corporation, etc.)

Name of Business (D/B/A): Foot Wedge Lounge

Address of Premise: 3212 Old Highway 75

Address Line 2:

City: Sloan

County: Woodbury

Zip: 51055

Business Phone: (712) 428-9993 Cell / Home Phone: (712) 490-2580

Same Address

Mailing Address: PO Box 425

Mailing Address Line 2:

City: Sloan State: Iowa

Zip: 51052

Contact Name: Jake Goodin

Phone: (712) 490-7034 Email Address: jake.goodin@goodinins.com

⏪ Prev

Next ⏩

Follow us with RSS, Facebook or Twitter



Contact Us

Iowa Alcoholic Beverages Division
 1918 SE Hulsizer Road, Ankeny, IA 50021
 Toll Free 866.IowaABD (866.469.2223)
 Local 515.281.7400

[Terms and Conditions](#)
[Privacy Policy](#)

Copyright ©2009 State of Iowa
 Alcoholic Beverages Division. All Rights Reserved.

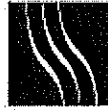

State of Iowa
ALCOHOLIC BEVERAGES DIVISION

- About
- Alcohol
- Tobacco
- Links
- Contact

-
-
-
-
-

Help	License Search	License List	On-Demand Reporting	Keg Registration Search	User Profile	Logoff
------	----------------	--------------	---------------------	-------------------------	--------------	--------

- License
- Privileges
- Applicant
- Status Of Business
- Ownership - Names
- Ownership - Interests
- Criminal History
- Premises
- General Premises
- Applicant Signature
- Dram Cert
- Local Endorse
- History

Status of Business LC_V_71009, Foot Wedge Lounge, Sloan

After completion click on the NEXT link to continue to the next screen, or the BACK link to return to the previous screen.
The navigation links on the top may also be used to move around the application.

Indicate how the business will be operated (Choose one of the following):

<input type="radio"/> Sole Proprietorship	<input type="radio"/> Publicly Traded Corporation
<input type="radio"/> General Partnership	<input type="radio"/> Limited Liability Company
<input type="radio"/> Limited Partnership	<input type="radio"/> Municipality
<input checked="" type="radio"/> Privately-Held Corporation	

Corporate ID Number: 63253 Federal Employer ID#: 420940121

Federal Employer ID Applied For:

 Prev

Next 

Follow us with RSS, Facebook or Twitter



Contact Us

Iowa Alcoholic Beverages Division
1918 SE Hulsizer Road, Ankeny, IA 50021
Toll Free 866.IowaABD (866.469.2223)
Local 515.281.7400

- Terms and Conditions
- Privacy Policy

Copyright ©2009 State of Iowa
Alcoholic Beverages Division. All Rights Reserved.



State of Iowa
ALCOHOLIC
BEVERAGES DIVISION
About
Alcohol
Tobacco
Links
Contact

- [Help](#)
- [License Search](#)
- [License List](#)
- [On-Demand Reporting](#)
- [Keg Registration Search](#)
- [User Profile](#)
- [Logoff](#)

Ownership LC_V_71009, Foot Wedge Lounge, Sloan

- > License
- > Privileges
- > Applicant
- > Status Of Business
- > Ownership - Names
- > Ownership - Interests
- > Criminal History
- > Premises
- > General Premises
- > Applicant Signature
- > Dram Cert
- > Local Endorse
- > History

After completion click on the NEXT link to continue to the next screen, or the BACK link to return to the previous screen. The navigation links on the top may also be used to move around the application.

Corporate applicant's, list all shareholders having 10% or more interest in the corporation and all officers and directors of the corporation regardless of ownership interest. Sole Proprietors shall also include their spouse even if the spouse owns 0% interest. Non-profit corporations or associations need to list officers. Partnerships and Committees not registered with the Secretary of State office will need a trade name filing from their county recorder's office.

If you want to change ownership information at renewal time please finish the renewal with the current ownership listed. When you are finished please go to the Action List and submit an Ownership Update Application along with the license renewal.

Owners:

Name	Address	Percentage	
Jacob Goodin	1369 220th St, Sergeant Bluff, IA, 51054	0.00 %	View
1			

First Name: Last Name:
 Address:
 Address Line 2:
 City: State:
 Zip:
 Position: SS#: U.S. Citizen:
 Date of Birth: MM/DD/YYYY % of Ownership:

Please make sure you press "Add" after each owner's information is listed above before pushing the next button.

[Prev](#)

[Next](#)

Follow us with RSS, Facebook or Twitter



Contact Us

Iowa Alcoholic Beverages Division
1918 SE Hulsizer Road, Ankeny, IA 50021
Toll Free 866.IowaABD (866.469.2223)
Local 515.281.7400

[Terms and Conditions](#)
[Privacy Policy](#)

Copyright ©2009 State of Iowa
Alcoholic Beverages Division. All Rights Reserved.



- Home
- About
- Alcohol
- Tobacco
- Links
- Contact

-
-
-
-
-

Help	License Search	License List	On-Demand Reporting	Keg Registration Search	User Profile	Logoff
------	----------------	--------------	---------------------	-------------------------	--------------	--------

Ownership Interests LC_V_71009, Foot Wedge Lounge, Sloan

- License
- Privileges
- Applicant
- Status Of Business
- Ownership - Names
- Ownership - Interests
- Criminal History
- Premises
- General Premises
- Applicant Signature
- Dram Cert
- Local Endorse
- History

After completion click on the NEXT link to continue to the next screen, or the BACK link to return to the previous screen.

The navigation links on the top may also be used to move around the application.

The following questions apply to the applicant and all persons and entities listed in the "Ownership - Names" section. The term "interest" means engaged in the ownership, conduct, or operation. Please direct any questions to info@iowaabd.com.

Question 1 of 6: Do you or any of your employees, agents, jobbers, representatives, directors, or officers have a direct or indirect interest in any liquor, wine or beer manufacturer, bottler, importer, wholesaler or broker in Iowa, the United States or outside the United States?

YES - PROVIDE THE FOLLOWING

NO

Next

Follow us with RSS, Facebook or Twitter



Contact Us

Iowa Alcoholic Beverages Division
1918 SE Hulsizer Road, Ankeny, IA 50021
Toll Free 866.IowaABD (866.469.2223)
Local 515.281.7400

- Terms and Conditions
- Privacy Policy

Copyright ©2009 State of Iowa
Alcoholic Beverages Division. All Rights Reserved.



- About
- Alcohol
- Tobacco
- Links
- Contact

Help	License Search	License List	On-Demand Reporting	Keg Registration Search	User Profile	Logoff
------	----------------	--------------	---------------------	-------------------------	--------------	--------

- License
- Privileges
- Applicant
- Status Of Business
- Ownership - Names
- Ownership - Interests
- Criminal History
- Premises
- General Premises
- Applicant Signature
- Dram Cert
- Local Endorse
- History

Ownership Interests LC_V_71009, Foot Wedge Lounge, Sloan

After completion click on the NEXT link to continue to the next screen, or the BACK link to return to the previous screen.

The navigation links on the top may also be used to move around the application.

The following questions apply to the applicant and all persons and entities listed in the "Ownership - Names" section. The term "interest" means engaged in the ownership, conduct, or operation. Please direct any questions to info@iowaabd.com.

Question 2 of 6: Does any liquor, wine or beer manufacturer, bottler, importer, wholesaler or broker in Iowa, the United States or outside the United States have a direct or indirect interest in your business?

YES - PROVIDE THE FOLLOWING

NO

Prev

Next

Follow us with RSS, Facebook or Twitter



Contact Us

Iowa Alcoholic Beverages Division
 1918 SE Hulsizer Road, Ankeny, IA 50021
 Toll Free 866.IowaABD (866.469.2223)
 Local 515.281.7400

- Terms and Conditions
- Privacy Policy

Copyright ©2009 State of Iowa
 Alcoholic Beverages Division. All Rights Reserved.

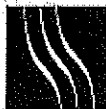

State of Iowa
**ALCOHOLIC
BEVERAGES DIVISION**

- Home
- About
- Alcohol
- Tobacco
- Links
- Contact

-
-
-
-
-

Help	License Search	License List	On-Demand Reporting	Keg Registration Search	User Profile	Logoff
------	----------------	--------------	---------------------	-------------------------	--------------	--------

Ownership Interests LC_V_71009, Foot Wedge Lounge, Sloan

- License
- Privileges
- Applicant
- Status Of Business
- Ownership - Names
- Ownership - Interests
- Criminal History
- Premises
- General Premises
- Applicant Signature
- Dram Cert
- Local Endorse
- History

After completion click on the NEXT link to continue to the next screen, or the BACK link to return to the previous screen.

The navigation links on the top may also be used to move around the application.

The following questions apply to the applicant and all persons and entities listed in the "Ownership - Names" section. The term "interest" means engaged in the ownership, conduct, or operation. Please direct any questions to info@iowaabd.com.

Question 3 of 6: Has any liquor, wine or beer manufacturer, bottler, importer, wholesaler or broker in Iowa, the United States or outside the United States paid all or part of your license fee?

YES - PROVIDE THE FOLLOWING

NO

Prev

Next

Follow us with RSS, Facebook or Twitter



Contact Us

Iowa Alcoholic Beverages Division
1918 SE Hulsizer Road, Ankeny, IA 50021
Toll Free 866.IowaABD (866.469.2223)
Local 515.281.7400

- Terms and Conditions
- Privacy Policy

Copyright ©2009 State of Iowa
Alcoholic Beverages Division. All Rights Reserved.



- Home
- About
- Alcohol
- Tobacco
- Links
- Contact

Help	License Search	License List	On-Demand Reporting	Keg Registration Search	User Profile	Logoff
------	----------------	--------------	---------------------	-------------------------	--------------	--------

Ownership Interests LC_V_71009, Foot Wedge Lounge, Sloan

- » License
- » Privileges
- » Applicant
- » Status Of Business
- » Ownership - Names
- » Ownership - Interests
- » Criminal History
- » Premises
- » General Premises
- » Applicant Signature
- » Dram Cert
- » Local Endorse
- » History

After completion click on the NEXT link to continue to the next screen, or the BACK link to return to the previous screen.

The navigation links on the top may also be used to move around the application.

The following questions apply to the applicant and all persons and entities listed in the "Ownership - Names" section. The term "interest" means engaged in the ownership, conduct, or operation. Please direct any questions to info@iowaabd.com.

Question 4 of 6: Has any liquor, wine or beer manufacturer, bottler, importer, wholesaler or broker in Iowa, the United States or outside the United States provided any loan, credit, money, gift or equivalent to you?

YES - PROVIDE THE FOLLOWING

NO

Prev

Next

Follow us with RSS, Facebook or Twitter



Contact Us

Iowa Alcoholic Beverages Division
 1918 SE Hulsizer Road, Ankeny, IA 50021
 Toll Free 866.IowaABD (866.469.2223)
 Local 515.281.7400

- Terms and Conditions
- Privacy Policy

Copyright ©2009 State of Iowa
 Alcoholic Beverages Division. All Rights Reserved.

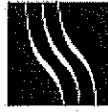

State of Iowa
**ALCOHOLIC
BEVERAGES DIVISION**

- About
- Alcohol
- Tobacco
- Links
- Contact

-
-
-
-
-

Help	License Search	License List	On-Demand Reporting	Keg Registration Search	User Profile	Logoff
----------------------	--------------------------------	------------------------------	-------------------------------------	---	------------------------------	------------------------

Ownership Interests LC_V_71009, Foot Wedge Lounge, Sloan

- [License](#)
- [Privileges](#)
- [Applicant](#)
- [Status Of Business](#)
- [Ownership - Names](#)
- [Ownership - Interests](#)
- [Criminal History](#)
- [Premises](#)
- [General Premises](#)
- [Applicant Signature](#)
- [Dram Cert](#)
- [Local Endorse](#)
- [History](#)

After completion click on the NEXT link to continue to the next screen, or the BACK link to return to the previous screen.
The navigation links on the top may also be used to move around the application.

The following questions apply to the applicant and all persons and entities listed in the "Ownership - Names" section. The term "interest" means engaged in the ownership, conduct, or operation. Please direct any questions to info@iowaabd.com.

Question 5 of 6: Does any liquor, wine or beer manufacturer, bottler, importer, wholesaler or broker in Iowa, the United States or outside the United States own or have an interest in your furnishings, fixtures, or equipment?

YES - PROVIDE THE FOLLOWING

NO

[Next](#)

Follow us with RSS, Facebook or Twitter



Contact Us

Iowa Alcoholic Beverages Division
1918 SE Hulsizer Road, Ankeny, IA 50021
Toll Free 866.IowaABD (866.469.2223)
Local 515.281.7400

-
-

- [Terms and Conditions](#)
- [Privacy Policy](#)

Copyright ©2009 State of Iowa
Alcoholic Beverages Division. All Rights Reserved.

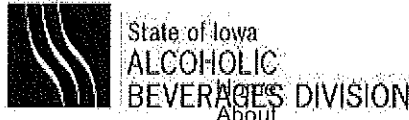

- About
- Alcohol
- Tobacco
- Links
- Contact

-
-
-
-
-

Help	License Search	License List	On-Demand Reporting	Keg Registration Search	User Profile	Logoff
------	----------------	--------------	---------------------	-------------------------	--------------	--------

Ownership Interests LC_V_71009, Foot Wedge Lounge, Sloan

- License
- Privileges
- Applicant
- Status Of Business
- Ownership - Names
- Ownership - Interests
- Criminal History
- Premises
- General Premises
- Applicant Signature
- Dram Cert
- Local Endorse
- History

After completion click on the NEXT link to continue to the next screen, or the BACK link to return to the previous screen.

The navigation links on the top may also be used to move around the application.

The following questions apply to the applicant and all persons and entities listed in the "Ownership - Names" section. The term "interest" means engaged in the ownership, conduct, or operation. Please direct any questions to info@iowaabd.com.

Question 6 of 6: Are you or any of your employees, agents, jobbers, representatives, directors or officers also employed by any liquor, wine or beer manufacturer, bottler, importer, wholesaler or broker in Iowa, the United States or outside the United States?

YES - PROVIDE THE FOLLOWING

NO

Next

Follow us with RSS, Facebook or Twitter



Contact Us

Iowa Alcoholic Beverages Division
 1918 SE Hulsizer Road, Ankeny, IA 50021
 Toll Free 866.IowaABD (866.469.2223)
 Local 515.281.7400

- Terms and Conditions
- Privacy Policy

Copyright ©2009 State of Iowa
 Alcoholic Beverages Division. All Rights Reserved.

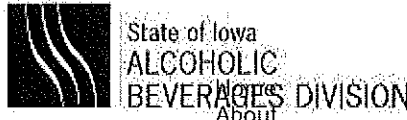

- Home
- About
- Alcohol
- Tobacco
- Links
- Contact

-
-
-
-
-
-

Help	License Search	License List	On-Demand Reporting	Keg Registration Search	User Profile	Logoff
------	----------------	--------------	---------------------	-------------------------	--------------	--------

- License
- Privileges
- Applicant
- Status Of Business
- Ownership - Names
- Ownership - Interests
- Criminal History
- Premises
- General Premises
- Applicant Signature
- Dram Cert
- Local Endorse
- History

Criminal History LC_V_71009, Foot Wedge Lounge, Sloan

After completion click on the NEXT link to continue to the next screen, or the BACK link to return to the previous screen.

The navigation links on the top may also be used to move around the application.

No ▼	Have you ever been convicted of a felony offense in Iowa or any other state of the United States? If yes, list on the next (Violations) screen.
No ▼	Have any of the owners listed in the ownership screen ever been charged, arrested, indicted, convicted or received a deferred judgment for any violation of any state, county, city, federal or foreign law? All information shall be reported regardless of the disposition, even if dismissed or expunged. Include pending charges. DO NOT include traffic violations, except those that are alcohol related. If yes, list violations on the next (Violations) screen.
None ▼	If no arrests, indictments, summons or convictions are applicable select "NONE".

⏪ Prev

Next ⏩

Follow us with RSS, Facebook or Twitter



Contact Us

Iowa Alcoholic Beverages Division
 1918 SE Hulsizer Road, Ankeny, IA 50021
 Toll Free 866.IowaABD (866.469.2223)
 Local 515.281.7400

- Terms and Conditions
- Privacy Policy

Copyright ©2009 State of Iowa
 Alcoholic Beverages Division. All Rights Reserved.

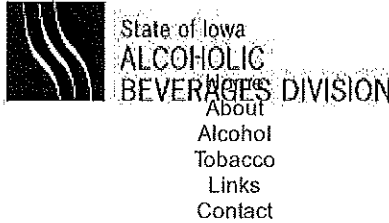

- Help
- License Search
- License List
- On-Demand Reporting
- Keg Registration Search
- User Profile
- Logoff

- License
- Privileges
- Applicant
- Status Of Business
- Ownership - Names
- Ownership - Interests
- Criminal History
- Premises
- General Premises
- Applicant Signature
- Dram Cert
- Local Endorse
- History

Premises Information LC_V_71009, Foot Wedge Lounge, Sloan

After completion click on the NEXT link to continue to the next screen, or the BACK link to return to the previous screen.
The navigation links on the top may also be used to move around the application.

Control of premises:

- Own
- Lease
- Other

explain:

Submit a signed copy of the lease/rental agreement for the license period or signed final sales contract or warranty deed to your local authority.

Submit a sketch to the Local Authority on 8 1/2 x 11' white paper of the proposed premises showing all areas under the control or lease of the Applicant. Include all floors where alcoholic beverages will be sold, served, consumed and stored. Indicate all entrances and exits, location of bar, back bar, and bathrooms. Please provide a separate sketch for each floor. If Applicant has Outdoor Service Area Privilege, please include in the sketch it's relationship to the licensed premises.

Boat Applicants Only: Submit a sketch to the Local Authority on 8 1/2 x 11' white paper of the proposed premises showing all areas under the control or lease of the Applicant. Include all decks where alcoholic beverages will be sold, served, consumed and stored. Indicate all entrances and exits, location of bar, back bar, bathrooms and where licenses will be displayed. Please provide a separate sketch for each deck. A separate sketch is required for each boat.

Premises type:

Local Authority:

License City:

License County:

City Population: 973

County Population: 102172

Dram Shop:

Prev

Next

Follow us with RSS, Facebook or Twitter



Contact Us

Iowa Alcoholic Beverages Division
1918 SE Hulsizer Road, Ankeny, IA 50021
Toll Free 866.IowaABD (866.469.2223)
Local 515.281.7400



- About
- Alcohol
- Tobacco
- Links
- Contact

Help	License Search	License List	On-Demand Reporting	Keg Registration Search	User Profile	Logoff
------	----------------	--------------	---------------------	-------------------------	--------------	--------

- License
- Privileges
- Applicant
- Status Of Business
- Ownership - Names
- Ownership - Interests
- Criminal History
- Premises
- General Premises
- Applicant Signature
- Dram Cert
- Local Endorse
- History

General Premises Information LC_V_71009, Foot Wedge Lounge, Sloan

After completion click on the NEXT link to continue to the next screen, or the BACK link to return to the previous screen.

The navigation links on the top may also be used to move around the application.

of Bathrooms:

of Floors:

Equipped with tables and seats to accommodate a minimum of 25?

Are other liquor, wine or beer businesses accessible from the interior of your premises?

Does your premises conform to all local and state health, fire and building laws and regulation?

Is the capacity of your establishment over 200?

Do you charge a cover charge?

If yes, how often?

Infusing [click here for more information](#)

- I will be mixing and storing mixed drinks, cocktails, or infusions prior to a customer placing an order for the beverage.
I will mix, store, and dispense mixed drinks, cocktails or infusions which are not for immediate consumption in compliance with the requirements and restrictions provided in Iowa Code § 123.49(2)"d"(2) and 185 Iowa Administrative Code § 4.5. I understand that a failure to comply with applicable laws and rules will result in a fine, license suspension, and/or license revocation.
- Agree Disagree
- I will NOT be mixing and storing mixed drinks, cocktails, or infusions prior to a customer placing an order for the beverage.

[Prev](#)

[Next](#)

Follow us with RSS, Facebook or Twitter



Contact Us

Iowa Alcoholic Beverages Division
 1918 SE Hulsizer Road, Ankeny, IA 50021
 Toll Free 866.IowaABD (866.469.2223)
 Local 515.281.7400

[Terms and Conditions](#)

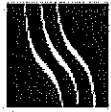

State of Iowa
ALCOHOLIC
BEVERAGES DIVISION

- About
- Alcohol
- Tobacco
- Links
- Contact

Help	License Search	License List	On-Demand Reporting	Keg Registration Search	User Profile	Logout
------	----------------	--------------	---------------------	-------------------------	--------------	--------

- » License
- » Privileges
- » Applicant
- » Status Of Business
- » Ownership - Names
- » Ownership - interests
- » Criminal History
- » Premises
- » General Premises
- » Applicant Signature
- » Dram Cert
- » Local Endorse
- » History

Applicant Signature LC_V_71009, Foot Wedge Lounge, Sloan

Complete the information below and click Finish to complete the application
Note that the license fees will only be withdrawn from accounts after the ABD approves the license.

This application must be completed by a person listed in the Ownership Section.

I hereby declare that all information contained in the Application is true and correct. I understand that misrepresentation of material facts in the Application is a crime and grounds for denial of the license or permit under Iowa law. I further understand that, as a condition of receiving a license, the licensed premises is subject to inspection during business hours by appropriate local, state and federal officials.

NOTE: The Applicant's Name must match one of the owner's names from the Ownership screen.

Owner's Signature: Date:
MM/DD/YYYY

Tentative effective date: MM/DD/YYYY

Licensees are required to submit a bi-annual report of shipment to Iowa consumers due January 10th and July 10th for the previous six months of shipment. This report can be found on the "Action List" under "Complete a Tax Report".

Amount to be transferred from your account: \$ 624.00

Please notify your Financial Institution to allow ACH debits by our agency's ACH ID number, 142-6004553.

Funds will be pulled from your account 2 days after ABD approves the license. You are ready to submit the application for your license to sell alcoholic beverages in the State of Iowa. By providing the bank information requested and clicking on "finish" you are indicating that you are an owner or authorized user of the bank account listed and that you hereby authorize ABD to debit the account in the amount indicated above.

NAME	0123
ADDRESS	0123456789
CITY, STATE, ZIP	
PAY TO THE ORDER OF	\$
BANK NAME	DOLLARS
ADDRESS	
CITY, STATE, ZIP	
⑆012345678⑆ 01234567890123⑆ 0123	

Bank Routing Number Bank Account Number Check Number

Applicant's Bank Name:

Applicant's Bank Routing Number: XXXXXXXXXXXXXXXXXXXX

Repeat Bank Routing Number:

The routing number will ALWAYS be 9 digits long. If you are unsure of your routing or account number, call your bank.

Applicant's Account Number: XXXXXXXXXXXXXXXXXXXX

Repeat Account Number:

Credit cards are not accepted. Your bank information is transferred over a secure connection and is completely confidential.

BY CLICKING ON THE "FINISH" BUTTON, I AGREE TO THE TERMS AND CONDITIONS OF USING MY BANK ACCOUNT AS A PAYMENT METHOD, WHICH ARE LISTED BELOW, AND AUTHORIZE THE STATE OF IOWA TO DEBIT MY BANK ACCOUNT FOR THE LICENSING FEE LISTED ABOVE.

1. Bank Account Payments. By choosing to use a bank account as your payment method...

Please print a copy of this page for your records before clicking the "FINISH" button.

Print Notary Form

Finish

If you are not taken to a confirmation screen after clicking on "Finish", please see the notes at the top of the applicant signature screen to find out why the application was not submitted.

Prev

Follow us with RSS, Facebook or Twitter



Contact Us

Iowa Alcoholic Beverages Division
1918 SE Hulsizer Road, Ankeny, IA 50021
Toll Free 866.IowaABD (866.469.2223)
Local 515.281.7400

Terms and Conditions
Privacy Policy

Copyright ©2009 State of Iowa
Alcoholic Beverages Division. All Rights Reserved.

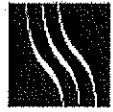

State of Iowa
ALCOHOLIC BEVERAGES DIVISION

- About
- Alcohol
- Tobacco
- Links
- Contact

- Help
- License Search
- License List
- On-Demand Reporting
- Keq Registration Search
- User Profile
- Logoff

- License
- Privileges
- Applicant
- Status Of Business
- Ownership - Names
- Ownership - Interests
- Criminal History
- Premises
- General Premises
- Applicant Signature
- Dram Cert
- Local Endorse
- History

Dram Shop Liability Certificate of Insurance LC_V_71009, Foot Wedge Lounge, Sloan

Complete the information below and click **SUBMIT** to endorse this New application.

POLICY INFORMATION	
Reason for re-submittal:	
This is to certify: <i>Illinois Casualty Co</i>	
Policy Number:	LL102487
Assured:	Sloan Community Recreation Corp
DBA:	Foot Wedge Lounge
Address:	3212 Old Highway 75
Address Line 2:	
City:	Sloan
State:	Iowa
Zip:	51055
Policy Effective Date:	03/15/2017 MM/DD/YYYY
To: <input checked="" type="radio"/>	Expiration Date: 11/15/2017 MM/DD/YYYY
Thru: <input type="radio"/>	

CHECK LIST	
<input checked="" type="checkbox"/>	Outdoor Service Endorsement
<input checked="" type="checkbox"/>	Policy Information Verified (if incorrect please contact the licensee)
Does this policy contain an annual aggregate limit provision?	No
If Yes, Annual aggregate limit is:	Please Select

The above-mentioned policy of insurance (hereinafter policy) contains coverage to comply with the provisions of Iowa Code section 123.92 and all regulations of the Iowa Department of Commerce, Alcoholic Beverages Division.

The policy may be canceled by the Company of the Assured giving 30 days notice in writing to the Alcoholic Beverages Division at its office, Ankeny, Iowa. The 30 days notice will commence from the date notice is actually received by the division.

Whenever requested by the division, the company agrees to furnish to the division a duplicate original of the policy and all pertinent endorsements.

Signature: Date: 03/07/2017 MM/DD/YYYY

Submit

Follow us with RSS, Facebook or Twitter



Contact Us



- Help
- License Search
- License List
- On-Demand Reporting
- Keg Registration Search
- User Profile
- Logoff

Local Authority Endorsement LC_V_71009, Foot Wedge Lounge, Sloan

- > License
- > Privileges
- > Applicant
- > Status Of Business
- > Ownership - Names
- > Ownership - Interests
- > Criminal History
- > Premises
- > General Premises
- > Applicant Signature
- > Dram Cert
- > Local Endorse
- > History

Complete the information below and click **SUBMIT** to endorse the New.

LICENSE INFORMATION

Local Authority: *County of Woodbury*

Daytime Phone for Local Authority:

License Approved
 License Denied Reason For Denial:
 Outdoor Service Area Approved
 Outdoor Service Area Denied

Effective Date:

CHECK LIST

Sketch on file
 Lease, Final Sales Contract or Warranty Deed on file
 Premise's address correct
 Notarized statement on file
 Premise zoned properly

Fire inspection completed: Yes No
 Health inspection completed: Yes No
 Was a DCI background check run: Yes No

Previous license number for this location:

Fee Amount: \$624.00
 Local Authority Share: \$260.00

E-MAIL

Please provide the local authority email address below. Once the application has been reviewed and approved, a copy of the license will be emailed to this address.

Local Authority E-mail Address

COMMENTS

Signature: Date: MM/DD/YYYY

Submit

Follow us with RSS, Facebook or Twitter



Contact Us

Iowa Alcoholic Beverages Division
 1918 SE Hulsizer Road, Ankeny, IA 50021
 Toll Free 866.IowaABD (866.469.2223)
 Local 515.281.7400

[Terms and Conditions](#)
[Privacy Policy](#)

HUMAN RESOURCES DEPARTMENT

MEMORANDUM OF PERSONNEL TRANSACTIONS

DATE: March 21, 2017

* PERSONNEL ACTION CODE:

- A- Appointment
- T - Transfer
- P - Promotion
- D - Demotion
- R-Reclassification
- E- End of Probation
- S - Separation
- O - Other

TO: **WOODBURY COUNTY BOARD OF SUPERVISORS**

NAME	DEPARTMENT	EFFECTIVE DATE	JOB TITLE	SALARY REQUESTED	% INCREASE	*	REMARKS
Brown, Benjamin	County Sheriff	4-01-17	Sheriff Deputy	\$27.73/hour	6%=\$1.69/hr	R	Per CWA Deputy Sheriff Contract agreement, from Class 1 to Senior Class due to 4 years employment and Bachelor's Degree.
Britton, Andrew	Juvenile Detention	4-09-17	P/T Youth Worker	\$22.60/hour	17%=\$3.28/hr	R	Per AFSCME Juvenile Detention Contract agreement, from Grade 1/Step 3 to Grade 1/Step 4.

APPROVED BY BOARD DATE: _____

ED GILLILAND, HR DIRECTOR: 

WOODBURY COUNTY
HUMAN RESOURCES DEPARTMENT

TO: Board of Supervisors and the Taxpayers of Woodbury County

FROM: Ed Gilliland, Human Resources Director

SUBJECT: Memorandum of Personnel Transactions

DATE: March 21, 2017

For the March 21, 2017 meeting of the Board of Supervisors and the Taxpayers of Woodbury County the Memorandum of Personnel Transactions will include:

- 1) County Sheriff Deputy, from Class 1 to Senior Class.
- 2) Juvenile Detention P/T Youth Worker, from Grade 1/Step 3 to Grade 1/Step 4.

Thank you

HUMAN RESOURCES DEPARTMENT

WOODBURY COUNTY, IOWA

DATE: March 21, 2017

AUTHORIZATION TO INITIATE HIRING PROCESS

DEPARTMENT	POSITION	ENTRY LEVEL	APPROVED	DISAPPROVED
County Treasurer	Motor Vehicle Clerk II	AFSCME Courthouse: \$15.64/hour		
	*Please see attached memo.			

Chairman, Board of Supervisors

To: Woodbury County Board of Supervisors
From: Michael Clayton
Date: March 14, 2017
Subject: Filling vacancy in the Motor Vehicle Department

I am requesting permission to fill the vacancy created in the Motor Vehicle Department by the retirement of Sue Everton.

Thank you for your time and consideration.

A handwritten signature in cursive script that reads "Michael R. Clayton". The signature is written in black ink and is positioned above the printed name and title.

Michael R. Clayton
Woodbury County Treasurer

cc Human Resources

WOODBURY COUNTY BOARD OF SUPERVISORS AGENDA ITEM(S) REQUEST FORM

#10

Date: 3/10/2017 Weekly Agenda Date: 3/21/2017

ELECTED OFFICIAL / DEPARTMENT HEAD / CITIZEN: Bob Fitch--Executive Director, LaunchPAD

WORDING FOR AGENDA ITEM:

Update on LaunchPAD Children's Museum

ACTION REQUIRED:

Approve Ordinance

Approve Resolution

Approve Motion

Public Hearing

Other: Informational

Attachments

EXECUTIVE SUMMARY:

Review of the Children's Museum first year and forecast of the future

BACKGROUND:

The Woodbury County Board invested \$75,000 in the capital campaign for the construction of LaunchPAD Children's Museum in downtown Sioux City. The museum recently marked its first anniversary and wants to take this opportunity to update the board about progress made during the first year of operation and provide a forecast of what the future holds.

FINANCIAL IMPACT:

n/a

IF THERE IS A CONTRACT INVOLVED IN THE AGENDA ITEM, HAS THE CONTRACT BEEN SUBMITTED AT LEAST ONE WEEK PRIOR AND ANSWERED WITH A REVIEW BY THE COUNTY ATTORNEY'S OFFICE?

Yes No

RECOMMENDATION:

n/a

ACTION REQUIRED / PROPOSED MOTION:

n/a

WOODBURY COUNTY BOARD OF SUPERVISORS AGENDA ITEM(S) REQUEST FORM

#11

Date: 3/15/2017 Weekly Agenda Date: 3/21/2017

ELECTED OFFICIAL / DEPARTMENT HEAD / CITIZEN: Patty Erickson-Puttmann Woodbury County MH/DS Coor

WORDING FOR AGENDA ITEM:

Consideration and approval of "Stepping Up" Resolution

ACTION REQUIRED:

Approve Ordinance

Approve Resolution

Approve Motion

Public Hearing

Other: Informational

Attachments

EXECUTIVE SUMMARY:

The Stepping Up Initiative is a national effort to advance county efforts to reduce the number of adults with mental illnesses in jails.

BACKGROUND:

The National Association of Counties has partnered with the Council of State Governments (CSG) Justice Center and the American Psychiatric Association Foundation (APAF) to launch a concentrated effort entitled "Stepping Up: A National Initiative to Reduce the Number of People with Mental Illnesses in Jails" and issue a Call to Action for county and state leadership.

FINANCIAL IMPACT:

NA

IF THERE IS A CONTRACT INVOLVED IN THE AGENDA ITEM, HAS THE CONTRACT BEEN SUBMITTED AT LEAST ONE WEEK PRIOR AND ANSWERED WITH A REVIEW BY THE COUNTY ATTORNEY'S OFFICE?

Yes No

RECOMMENDATION:

Participation in the Stepping Up Initiative through Sioux Rivers Regional Mental Health and Disabilities Services.

ACTION REQUIRED / PROPOSED MOTION:

Approval and passage of attached resolution.

RESOLUTION NO. _____

“Stepping Up to Reduce the Number of People with Mental Illnesses in Jails”

WHEREAS, counties routinely provide treatment services to the estimated 2 million people with serious mental illnesses booked into jail each year; and

WHEREAS, prevalence rates of serious mental illnesses in jails are three to six times higher than for the general public; and

WHEREAS, almost three-quarters of adults with serious mental illnesses in jails have co-occurring substance use disorders; and

WHEREAS, adults with mental illnesses tend to stay longer in jail and, upon release, are at a higher risk of recidivism than people without these disorders; and

WHEREAS, county jails spend two to three times more on adults with mental illnesses that require interventions compared to those without these treatment needs; and

WHEREAS, without the appropriate treatment and services, people with mental illnesses continue to cycle through the criminal justice system, often resulting in tragic outcomes for these individuals and their families; and

WHEREAS, Woodbury County, Iowa and all counties take pride in their responsibility to protect and enhance the health, welfare, and safety of its residents in efficient and cost-effective ways; and

WHEREAS, Woodbury County has developed as part of the Sioux Rivers Regional Mental Health and Disabilities Services the Assessment and Stabilization Center to assist persons with mental health needs to remain out of the hospitals and jails by providing treatment alternatives thereby preventing hospitalization through involuntary commitments and/or jails stays; and

WHEREAS, through Stepping Up, the National Association of Counties, The Council of State Governments Justice Center, and the American Psychiatric Association Foundation are encouraging public, private, and nonprofit partners to reduce the number of people with mental illnesses in jails.

NOW, THEREFORE, LET IT BE RESOLVED, THAT I, Matthew Ung, Chairman of the Woodbury County Board of Supervisors, do hereby sign on to the Call to Action to reduce the number of people with mental illnesses in our county jail, commit to sharing lessons learned with other counties in my state and across the country to support a national initiative and encourage all county officials, employees, and residents to participate in Stepping Up. We resolve to utilize the comprehensive resources available through Stepping Up to:

- Convene or draw on a diverse team of leaders and decision makers from multiple agencies committed to safely reducing the number of people with mental illnesses in jails;
- Collect and review prevalence numbers and assess individuals' needs to better identify adults entering jails with mental illnesses and their recidivism risk, and use that baseline information to guide decision making at the system, program, and case levels;
- Examine treatment and service capacity to determine which programs and services are available in the county for people with mental illnesses and co-occurring substance use disorders, and identify state and local policy and funding barriers to minimizing contact with the justice system and providing treatment and supports in the community;
- Develop a plan with measurable outcomes that draws on the jail assessment and prevalence data and the examination of available treatment and service capacity, while considering identified barriers;
- Implement research-based approaches that advance the plan; and
- Create a process to track progress using data and information systems, and to report on successes.

SO RESOLVED this 21st day of March, 2017.

ATTEST:

WOODBURY COUNTY BOARD OF SUPERVISORS

Patrick F. Gill
Woodbury County Auditor/Recorder

Matthew Ung, Chairman

WOODBURY COUNTY BOARD OF SUPERVISORS AGENDA ITEM(S) REQUEST FORM

#12

Date: 3/15/17 Weekly Agenda Date: 3/21/17

ELECTED OFFICIAL / DEPARTMENT HEAD / CITIZEN: Patrick Gill

WORDING FOR AGENDA ITEM:

Consideration of an amendment to the Board Bylaws

ACTION REQUIRED:

Approve Ordinance

Approve Resolution

Approve Motion

Give Direction

Other: Informational

Attachments

EXECUTIVE SUMMARY:

Chairman Ung recently implemented the use of a "consent agenda". The proposed amendment formalizes this process.

BACKGROUND:

The Board of Supervisors adopted bylaws to guide the process used in their meetings in 2014. The bylaws allow for amendment. This amendment would keep the bylaws current.

FINANCIAL IMPACT:

NA

IF THERE IS A CONTRACT INVOLVED IN THE AGENDA ITEM, HAS THE CONTRACT BEEN SUBMITTED AT LEAST ONE WEEK PRIOR AND ANSWERED WITH A REVIEW BY THE COUNTY ATTORNEY'S OFFICE?

Yes No

RECOMMENDATION:

Adopt the proposed amendment to the Board of Supervisor's bylaws.

ACTION REQUIRED / PROPOSED MOTION:

Motion to amend the Board of Supervisors bylaws by adopting the proposed amendment as submitted.

BYLAWS OF THE WOODBURY COUNTY BOARD OF SUPERVISORS

ARTICLE I Name

The name of this statutorily created assembly is the Woodbury County Board of Supervisors.

ARTICLE II Purpose

The purpose of this assembly is to perform the duties of the Board of Supervisors according to the Iowa Code.

ARTICLE III Members

There are five members of the Woodbury County Board of Supervisors. They are elected at large from Woodbury County, Iowa but with equal-population district residence requirements.

ARTICLE IV Officers

Section 1. Officers and Duties. The officers shall be a Chairperson, a Vice Chairperson and a Clerk to the Board. These officers shall perform the duties as prescribed by Iowa Code, these bylaws and by the parliamentary authority adopted by the Board in descending order.

- a. Chairperson.** The Chairperson shall preside at all the meetings of the Board during the year. The Chairperson shall make all committee assignments to committees recognized in these bylaws. The Chairperson shall set the tentative agenda for all meetings of the Board. The Chairperson shall oversee the daily operations of county administration while acting within the policies established by the Board. Subject to approval of the Board, the Chairperson shall be authorized, with a Board approved committee form, to establish special purpose committees as needed.
- b. Vice Chairperson.** The Vice Chairperson shall serve during the absence of the Chairperson and be the presiding officer when the Chairperson participates by electronic means.
- c. Clerk to the Board.** The Auditor and Recorder or the designee of the Auditor and Recorder shall serve as Clerk to the Board *ex officio*. The Clerk to the Board shall be recognized as the parliamentarian for all meetings of the Board.

Section 2. Time, Nomination Procedure, Method of Election and Term of Office. The election of The Chairperson and Vice Chairperson shall occur at the first meeting in each year. Nominations shall be made from the floor and elections shall be by roll call vote. A temporary chair shall be elected to preside over the election of the Chairperson. The Chairperson's term shall begin immediately. The Chairperson shall preside over the election of the Vice Chairperson.

ARTICLE V Meetings

Section 1. Compliance with Open Meetings Law. All meetings of the Board shall be scheduled and conducted in compliance with Chapter 21 of the Code of Iowa and other applicable law.

Section 2. First Meeting. The Board shall meet on the first day of January which is not a Saturday, Sunday or holiday.

Section 3. Regular Meetings. The Board shall hold regular meetings on each Tuesday of the year unless canceled or postponed by a majority of the Board.

Section 4. Special Meetings. The Board may hold special meetings from time to time as required to conduct the business of the county. A special meeting may be called by the Chairperson or by the Vice Chairperson in the absence of the Chairperson.

Section 5. Agenda. Items to be considered for a meeting shall be submitted in a format prescribed by the Board. All items requested for Board action shall be submitted in the form of a proposed written motion. Any member of the Board may direct the Chairperson to place an information or discussion item on the agenda of a subsequent meeting. The Chairperson shall place an action item on the agenda of a subsequent meeting when directed by a majority of the Board. The chairperson may place items of routine business on a consent agenda to be considered in gross by the Board without debate or amendment. A member may, at the time of approval of the agenda, ask for an item to be considered as a separate item.

Section 6. Quorum and Consensus. A quorum and consensus shall consist of three members of the Board. A quorum is required to transact the official business of the County.

Section 7. Majority Required. Unless where otherwise provided by law, a majority of the quorum present is required for the adoption of any matter to come before the Board.

Section 8. Manner of Acting. Any question to come before the Board shall be in the form of a motion made by a member and shall require a second for consideration. Remarks by members shall be limited to ten minutes unless an extension is granted by a majority of the Board. A member or any other elected official of the county shall address the Chairperson and confine their remarks to the question before the Board and shall be respectful of other elected officials and avoid referencing or questioning the motives of another elected official.

Section 9. Roll Call Votes. The Chairperson shall order a roll call vote when requested by a member. The roll shall be called alphabetically except the Chairperson shall be called last. If a member is not ready to vote, the member may pass and shall be called upon again after the roll has been completely called and shall vote or abstain.

Section 10. Effect of Abstention. When a member abstains due to a conflict of interest, the vote of the Board shall be computed on the basis of the number of members not disqualified by reason of conflict of interest. However, at least three (3) members eligible to vote are required for a quorum on any matter. Abstentions that are not due to a conflict of interest shall be counted as a “no” vote.

Section 11. Electronic Participation. A member of the Board may participate in a meeting by electronic means only in circumstances where participation in person is impossible or impractical. Any member participating electronically shall be connected by a speaker phone, video conference, or other device or software, so that the public can hear any discussion by that member. The vote of any member participating electronically must be made public at the meeting and the minutes of the meeting shall include sufficient information to indicate the vote of each member participating.

ARTICLE VI Committees

Section 1. Committees Required by Iowa Code. All Board representation on committees required by the Iowa Code shall be appointed by the Chairperson subject to approval of the Board.

Section 2. Committees Created by the provisions of Iowa Code Chapter 28E. All Board representation on committees required by 28E agreements shall be appointed by the Chairperson subject to approval of the Board and the requirements of the 28E agreement.

Section 3. Committees Created by Agreement. All Board representation on committees required by agreement shall be appointed by the Chairperson subject to approval of the Board.

Section 4. Committees Created for Special Purpose. All Board representation on committees required for a special purpose shall be appointed by the Chairperson subject to approval of the Board.

Section 5. Attendance at Committees Created Under Article VI. Attendance by members of the Board at committees created under Article VI of these bylaws shall be limited to those approved by the Board as committee representatives unless the committee meeting has also been posted as a special meeting of the Board of Supervisors.

ARTICLE VII Conflicts of Interest

Except as otherwise provided by law, members shall not have an interest, direct or indirect, in any contract, or job of work, or material, or the profits thereof, or services to be furnished or performed for Woodbury County. Members should avoid any action that would result in, or create the impression of, using public office for private gain, giving preferential treatment to any person, or losing impartiality in conducting county business.

**ARTICLE VIII
Parliamentary Authority**

The rules contained in the most current edition of Robert's Rules of Order Newly Revised shall govern the Board in all cases to which they are applicable and in which they are not inconsistent with the Iowa Code, these bylaws and any special rules of order that the Board may adopt.

**ARTICLE IX
Bylaws**

Section 1. Adoption of Bylaws. Bylaws shall be adopted at the first meeting in each year following a General Election.

Section 2. Amendment of Bylaws. These bylaws may be amended at any regular meeting of the Board with a majority vote, provided that the amendment has been submitted in writing at the previous regular meeting.

1/3/2017
DATE ADOPTED

CHAIRPERSON

ATTESTOR

WOODBURY COUNTY BOARD OF SUPERVISORS AGENDA ITEM(S) REQUEST FORM

#13

Date: 3/16/17

Weekly Agenda Date: 3/21/17

ELECTED OFFICIAL / DEPARTMENT HEAD / CITIZEN:

Keith Radig

WORDING FOR AGENDA ITEM:

Sale and Development of County owned parcels

ACTION REQUIRED:

Approve Ordinance

Approve Resolution

Approve Motion

Public Hearing

Other: Informational

Attachments

EXECUTIVE SUMMARY:

To increase tax base and remove ongoing maintenance costs for the county. Woodbury County should set a date and time for the chair to run a public auction to sell listed properties with development agreements

BACKGROUND:

Woodbury currently owns these parcels, and has been mowing and maintaining and assuming liability at a loss to the taxpayers.

1. 058230 1309 W. 14th Street

2. 058770 1415 Center Street

3. 058860 1123 W. 14th Street

058875 1402 Myrtle Street

4. 184005 21 1/2 17th Street

5. 269325 1802 W. 14th Street

6. 245430 1523 Nebraska Street

7. 246840 1821 Pierce Street (Not developable)

FINANCIAL IMPACT:

Only negative impacts would be time to complete the sale of the parcels. If these 7 properties were sold and developed, they would pay property tax every year.

IF THERE IS A CONTRACT INVOLVED IN THE AGENDA ITEM, HAS THE CONTRACT BEEN SUBMITTED AT LEAST ONE WEEK PRIOR AND ANSWERED WITH A REVIEW BY THE COUNTY ATTORNEY'S OFFICE?

Yes No

RECOMMENDATION:

We should move quickly to sell these parcels. Most of the properties should require that homes be developed or ^{commercial/multi-res.} in the next 3 years.

ACTION REQUIRED / PROPOSED MOTION:

I would like an action item on the agenda for the motion to set a public auction to sell the listed parcels, with or without a development agreement.

WOODBURY COUNTY BOARD OF SUPERVISORS AGENDA ITEM(S) REQUEST FORM

#14

Date: 3/19/2017 Weekly Agenda Date: 3/21/2017

ELECTED OFFICIAL / DEPARTMENT HEAD / CITIZEN: Supervisor Matthew Ung

WORDING FOR AGENDA ITEM:

Information regarding Radig's Agenda Item

ACTION REQUIRED:

- | | | |
|--|--|---|
| Approve Ordinance <input type="checkbox"/> | Approve Resolution <input type="checkbox"/> | Approve Motion <input type="checkbox"/> |
| Public Hearing <input type="checkbox"/> | Other: Informational <input checked="" type="checkbox"/> | Attachments <input checked="" type="checkbox"/> |

EXECUTIVE SUMMARY:

Supervisor Radig makes a public-bidder-related recommendation without background from the Public Bidder. I ended up being the one to ask for her input; it's attached for the benefit of board members.

BACKGROUND:

A 2016 annual review of the Public Bidder position was completed by then-Chairman Taylor and was distributed to the new supervisors this year. The new, noted goal of publishing county-owned lots on a periodic basis--in bulk, with summations on the bidding process for public knowledge--clashes with the priority placed on eight particular parcels without explanation as to why they are picked.

FINANCIAL IMPACT:

The County Attorney's Office either was not questioned or has not given an opinion on the legality of 3-year development agreements for parcels sold in a single, combined auction.

IF THERE IS A CONTRACT INVOLVED IN THE AGENDA ITEM, HAS THE CONTRACT BEEN SUBMITTED AT LEAST ONE WEEK PRIOR AND ANSWERED WITH A REVIEW BY THE COUNTY ATTORNEY'S OFFICE?

Yes No

RECOMMENDATION:

For the good of the public, the truth is that Woodbury County has not in any way dragged its feet in selling off parcels to generate tax revenue. More time is being spent on selling them quickly than ever before. The eight parcels Supervisor Radig lists are only eight of many that have been pro-actively offered multiple times to buyers for as little as \$1, and will continue to be offered.

ACTION REQUIRED / PROPOSED MOTION:

The outcome is unlikely to be directing the Public Bidder to spend time and money selling properties for which there is no interest at the expense of those for which there is... so perhaps an idea to generate interest should come first.

Information regarding Radig's agenda item

From: Heather Satterwhite
To: Matthew Ung
Date: Friday - March 17, 2017 4:21 PM
Subject: Information regarding Radig's agenda item

Hi Matthew - Please see the following information regarding the list of properties Keith has listed on his request form.

1309 W. 14th Street: On our Weed List given to Kenny. We have tried selling this lot in 2007, 2009, and 2012 for \$1 with no response.

1415 Center Street: On our Weed List. We have tried selling this lot in 2011 and 2014. We did have issues with this lot as they were parking their cars on the grass, so Building Maintenance placed No Parking/No Trespassing signs in the yard and we haven't had issues since. Boykin had \$500 as the minimum bid.

1123 W. 14th Street: On our Weed List. We have tried selling this 2008, 2012 and 2016. I had this on the November 29th, 2016 agenda to have the board approve the notice of property sale resolution but right beforehand the interested party was no longer interested. She has a vineyard next to the this lot and went to the city to see about using it for parking and they advised her she couldn't (I'm not 100% sure what the reason was from the city). The minimum bid was \$50.

1402 Myrtle Street: On our Weed List. This property is right next to the previous one at 1123 W. 14th Street. This was included in the \$50 minimum bid along with that property. They have both been offered for sale to adjoining property holders in 2008, 2012 and 2016.

He has this listed as 21 1/2 17th Street, actual address is 29 17th Street

29 17th Street: This is the huge property we own that is behind Bomgaars and all along 18th Street beyond that guardrail. For the longest time this was listed as Not for sale as we had issues with the legal description (I have since fixed that). The neighbor that lives at 111 17th Street has been interested in purchasing just a small piece of it next to their house but the board was never interested in splitting off the parcel. Joshua also recommended that we don't split the parcel. This was also the garage that had damage done to it from one of our trees falling onto it. I have offered to sell this to the City for \$1 on numerous occasions over the years and they were not interested. The problem with selling it is, the property owner is responsible for maintaining the sidewalk that is 6 blocks long along 18th Street. It would be in the best interest to sell this property if we could.

1802 W. 14th Street: This is on our Weed List. We have offered to sell this for \$1 in 2008 and 2012 with no response.

1523 Nebraska Street: This is on our Weed List. I obtained deed to this property for a man that owned the house next to it, but around the same time, he passed away. I did speak with the family, and they are trying to sell all of his properties and they aren't interested. Since then I have sent letters out to property owners in the area, with no response. The minimum bid was set at \$250.

1821 Pierce Street: This is on our Weed List. I obtained this property for Roger Caudron as he was interested. After obtaining deed, I contacted him to set up the sale. At that time, he advised me he was no longer interested. I then contacted the city and they advised me they were not interested either (even though they were initially). This lot is right next to Siouland Residential, which is vacant currently and up for sale. I have sent them two letters offering it for sale (minimum bid: \$279) and received no response. I had an individual show interest and ask to set up for sale, but did not show up for the auction last June. I don't know if the county would be interested in selling this just yet, as I have heard rumors that Casey's was interested in that block but would need our corner lot. So, could be a good money making lot. But then I thought if Caudron nor the city were interested anymore, maybe that deal fell through.

There are many lots like the one's listed above. Same history, same outcomes to my letters showing no interest, some are on our weed list and some are not.

Like I said, it is part of my performance evaluation as a goal to publish county owned lots quarterly in the official newspapers. This is to include a brief summation as to the nature of the public bidding process. As we all know, I have only been full-time with this office for less than a year. And until recently, with the clarification of my job duties, able to utilize my time to get these properties back on the tax rolls. I believe it is a task I can handle, but with the number of properties the county currently owns and the number of requests for me to obtain deed to properties, it does take time. Taking property from property owners is not an easy task and it's very time consuming, but it can be done.

As far as Development Agreements, we have never done that before, especially on small residential lots. We issue a Quit Claim Deed and that is all we can do. I also would like to work on these properties in the way I spoke about as far as publications and using social media if possible before we get into the practice of taking the time to set up public hearings and auctions when we aren't even aware of

interested buyers. I would like to be given a chance to do it my way, the way I feel can work, before wasting my time and money from the public bidder budget on legal publications. But, I'm always up for suggestions and better ways of doing things. I just feel I have given this my best effort over the years with the time I had available to do it. I'm in a better position at this point.

Sorry, I'm always wordy :)

Happy St. Patrick's Day!!!

Heather Satterwhite
Executive Secretary/Public Bidder
Woodbury County
Board of Supervisors
620 Douglas Street, Rm. 104
Sioux City, IA 51101
712-279-6525 Option #2

*****Please note that my email address has changed to: hsatterwhite@woodburycountyiowa.gov**

Privileged/confidential information may be contained in this message. If you are not the addressee indicated in this message (or responsible for delivery of the message to such person), you may not copy or deliver this message to anyone. In such case, you must destroy this message and kindly notify the sender by reply email. Please advise immediately if you or your employer does not consent to Internet email for messages of this kind.

WOODBURY COUNTY DEPARTMENT HEAD MEETING

March 20, 2017 – 8:00 a.m. – LEC Training Room

Vision: Woodbury County dedicates itself to providing high quality services to meet the ever-changing demands and needs of its citizens.

Goal/Objective: County department heads and elected officials will meet monthly using an agenda and minutes, documenting increased transparency, communication, cooperation, and efficient, long-term planning.

Agenda Focus 20 March 2017: On Focus & On Track

1. Welcome/Board Updates—M. Ung / J. Taylor

- Communication with your liaisons/supervisors—best practices; example handout
- Update on Board Office job descriptions
- Town Hall meeting—Correctionville Community Center, March 27, 6:30-8:00 p.m.

2. FY18 Budget Updates—D. Butler

Chairman Ung is asking the finance director to generate a Popular Annual Financial Report (PAFR) report similar to that put out by Linn County. This will qualify Woodbury County for a transparency award from the Government Finance Officers Association (GFOA), which heretofore has not been enjoyed by our populace. This is a goal which may require input, data, or wordsmithing from this group. Your help is appreciated as Mr. Butler may be reaching out to you while navigating/forming this new process.

3. Migration to Microsoft Exchange—J. Malloy

The hits just keep on coming with the prickly process of migrating emails to Microsoft Exchange, but to John Malloy, it's just a flesh wound. Our fearless IT Director will give us an update.

4. Emergency Management Update—R. Socknat

Further details will be shared on the Tornado Drill (March 29th). The AlertIA program will be used. There will also be details from the Security Committee meeting to report as it regards the credentialing/ID program.

5. Important Dates to Track

April 4 (10 a.m.)
May 3-4

Policy Review Committee
Washington, D.C. Lobbying Trip (Siouxland Chamber)

6. Department Activities—All Department Heads and Elected Officials

We will go around the room—Please let us know what is going on in your department that is a main priority of effort. You may also share an idea for cooperation or a need, but if extensive discussion ensues, we may ask it be a separate agenda item for the next meeting.

Next Department Head Meeting – April 17th

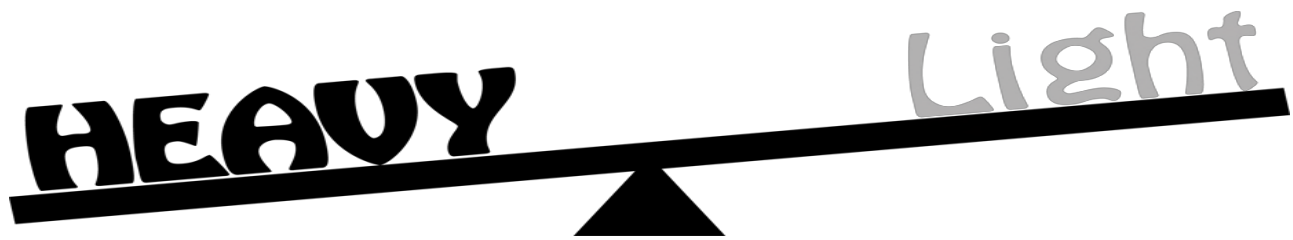

If cats could talk, they wouldn't.
~Nan Porter

You can't talk yourself out of
problems you behave yourself into.
~Stephen Covey



Agenda – Town Hall Meeting
Monday – March 27, 2017 at 6:30 p.m.
City of Correctionville, Community Center
312 Driftwood Street

Woodbury County Board of Supervisors
Rural Mayors of Woodbury County

- | | | |
|--|-----|--|
| Pledge of Allegiance | --- | Mayor Nathan Heilman,
Correctionville Council |
| Introductions | | |
| Update on County Activity | --- | Chairman Matthew Ung,
Woodbury County Board |
| Regional Updates from
Offices/Departments | --- | County Officials |
| Panel Discussion | --- | Supervisors & Mayors |
| • Growth Along Highway 20 Corridor/SIMP
CO Services | | |
| • Progress of Comprehensive Plans | | |
| • Rural Services | | |
| Questions / Comments / Open Dialogue
Discussion | | |

ADJOURNMENT

- *Subject to Additions/Deletions*

“To improve the lives of our employees and their families and to help fight the production of disease so the next generation may live healthier, happier and more productively”

Woodbury County Health Insurance Committee Meeting

AGENDA

March 21, 2017

2:30 pm

Old Board Room Woodbury County Courthouse

- I. Call the meeting to Order
- II. Health Insurance Fund Updates
 - Information regarding the percentage increase in health insurance funding for fiscal year 17/ 18.....Jeremy Taylor
 - Claims and trends information regarding Woodbury County’s health insurance account activity for the previous quarter.....Ed Gilliland
 - Comparable of the reserves for the health insurance fund for the previous 3 years....Ed Gilliland
 - Information regarding the changes in our Health Plan as of 01/01/17.....Ed Gilliland
- III. Disease Management
 - Information regarding the Disease Management Program through Wellmark, which assists employees and how to enrollEd Gilliland
- IV. Mercy Business
 - Update regarding 2016 Wellness Blood Draws including the participation, trends and results
 - Discussion regarding the possibility of offering optional blood draws for the entire family and the impact on our health plan
 - EAP discussion regarding the need for a local EAP provider and information about our current provider.....Deb Twyford and Devon Gurnett
- V. Naturally Slim
 - A simple online program that uses informative videos and learning tools to teach you how to lose weight and improve your health....Melissa Thomas
- VI. The recommendation for purchasing sit-stand equipment for approximately 75 employees at a cost of \$30,000 from our Health Fund is on the table....Jeremy Taylor
- VI. Questions
- VII. Adjournment

AGGREGATE REPORT



Woodbury County		11/01/2016 - 12/31/2016	CUMULATIVE GRADE
Overall Grades	NORMAL	BORDERLINE	HIGH RISK
	BLOOD PRESSURE B (3.27)		
	SMOKING B+ (3.37)		
	DIABETES B+ (3.5)		
	WEIGHT MANAGEMENT D+ (1.41)		
	CHOLESTEROL B- (2.99)		
<p>This Aggregate Report Card is intended to give an overview of health risk with a more in depth look at some ways these risks affect the health of participants. It is not a full analysis of the causes of health risk.</p> <p>This report highlights the areas of greatest risk based on prevalence. There may be areas of risk that have a low prevalence, but are of concern for your group. For example, there may be a low prevalence of participants who smoke, but this may still be an area that can be targeted for improvement.</p>			<p>B-</p> <p>2.77 GPA</p> <p>on a</p> <p>4.0 GPA</p>
			<p>10/01/2015 - 12/31/2015</p> <p>B-</p> <p>2.73 GPA</p>
			<p>10/01/2014 - 12/31/2014</p> <p>B-</p> <p>2.73 GPA</p>

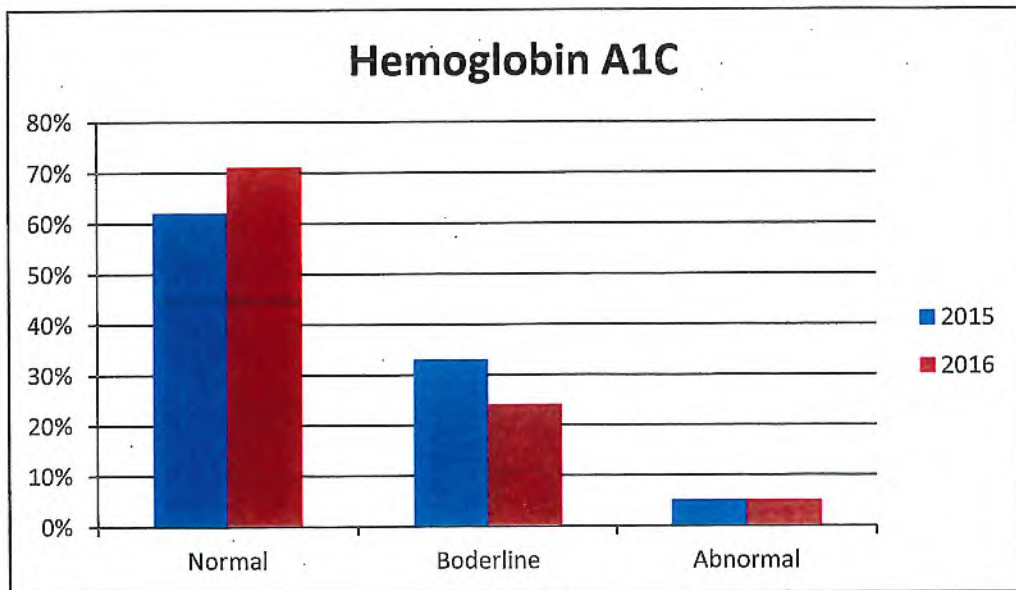
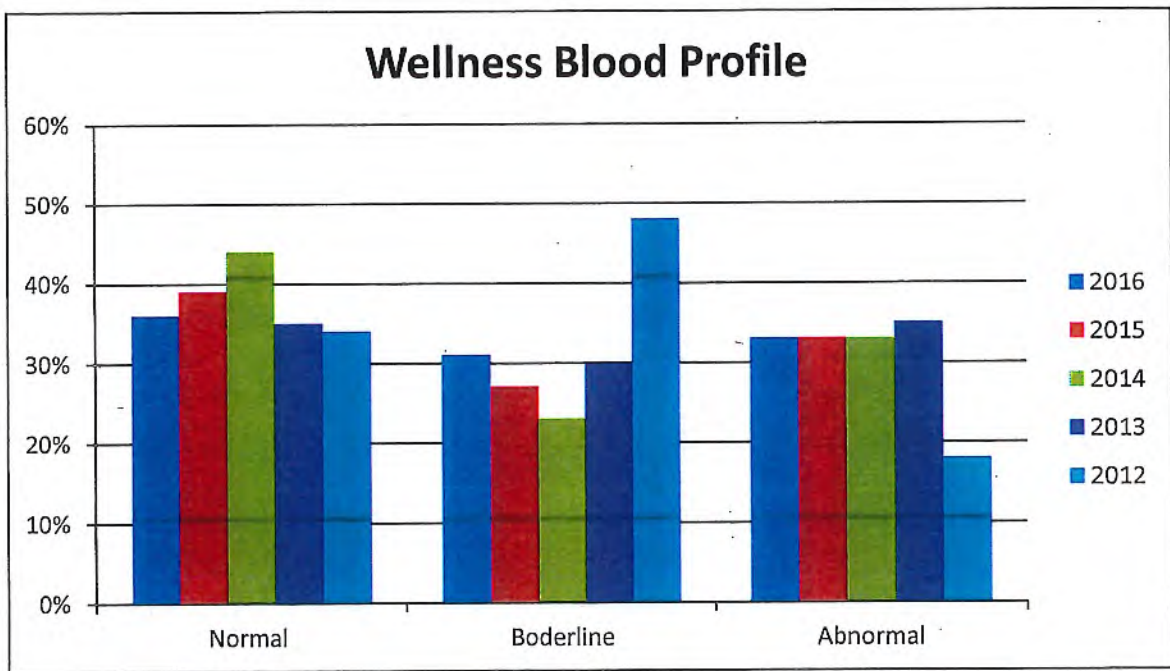
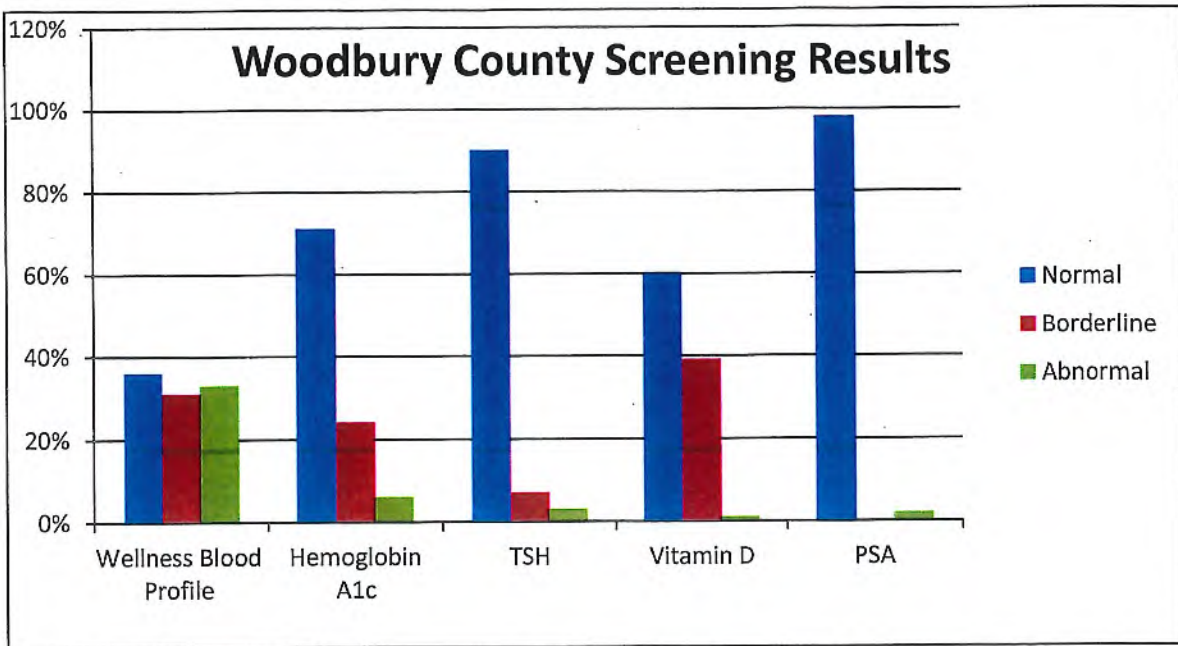

TSH Blood Test

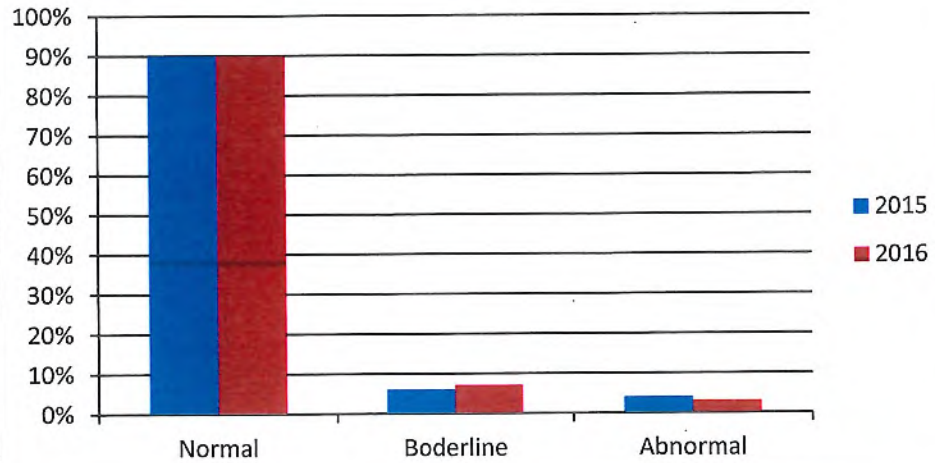

Vitamin D

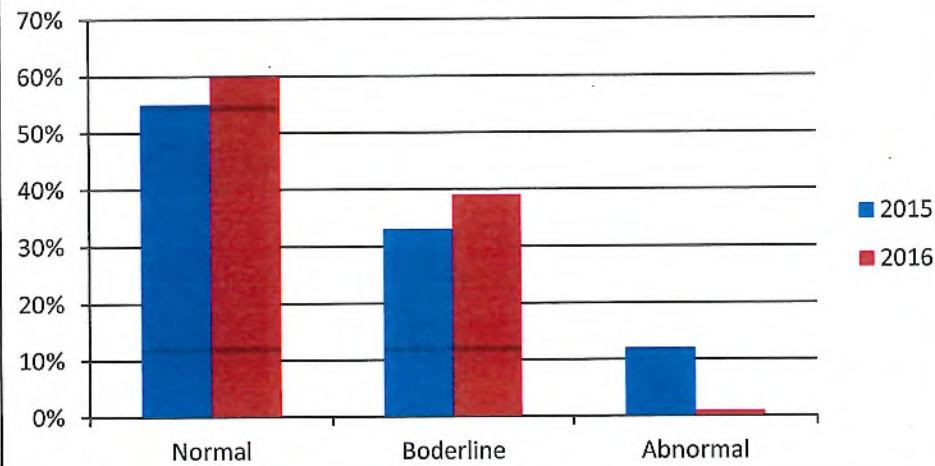

PSA

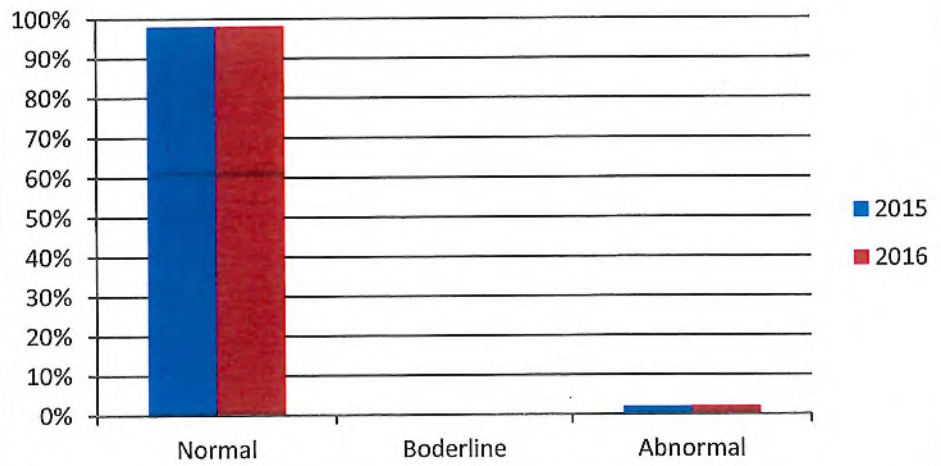

Personal Problems • Life Management • Family & Relationships • Wellness Information



Personal
Consultation/Assistance
For help call Toll-Free
1-800-437-0911

Carebridge Can Help!

ASSISTANCE WITH

Marriage • Addictions • Stress • Relationships • Separation / Divorce
Depression • Grief / Loss • Emotions • Family & Parenting • Child Care
Child Development • Adoption • Eldercare • Workplace Issues
Personal Finances • Education / Schools • Relocation • House Purchase / Sale
Wellness Information • Weight • Pet Care • Convenience / Concierge
Life Balance • Time Management • Legal Assistance • Wills

For Online Services logon to: www.myliferesource.com. Your Access Code is: EW7KK



BUSINESS HEALTH SERVICES

A service of Mercy Medical Center-Sioux City

natura)(yslim®



Proposal for Naturally Slim

September 19

Woodbury County

The not-a-diet online metabolic syndrome reversal and weight loss program that is changing lives and measurably improving corporate bottom lines.

Contents

Executive Summary	2
The Problem	3
The Financial Problem	3
The Solution (Naturally Slim)	4
The Results	5
The Financial Results	5
Pricing	6
Engagement Best Practices (pay-for-performance)	6
Additional Considerations (pay-for-performance)	6
Naturally Slim	7
The Naturally Slim Experience	8
User Experience	9
Naturally Slim Foundations	11
NS4You™ and NS4Life™	13
Implementation	14
Timeline	15
Sample Detailed Timeline	16
Communication	17
Reporting	18
References	19
Next Steps	20

natura)(yslim®

Affordable Care Act and preventive care guidance for intensive behavioral counseling

August 2014: USPSTF recommends physicians offer preventive intensive behavioral counseling for obesity, CVD, and diabetes prevention.



Affordable Care Act (Section 2713): private (non-grandfathered) health plans must provide coverage without cost sharing for preventive services (intensive behavioral counseling be in place by January 2016)

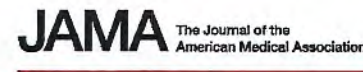

"...weight loss of as little as 3% to 5% is likely to result in clinically meaningful reductions in levels of triglycerides, blood glucose, and glycated hemoglobin and in the risk of developing type 2 diabetes..." (JAMA January 1, 2014 Volume 311, Number 1)



natura)(yslim®

Engagement Best Practices for Pay-for-Performance

For Pay-for-Performance pricing, Client agrees to ACAP Health best practices engagement model:

- **Announcement** – communicate via email to a broad employee population, not targeted to at-risk employees
- **Engagement** – distribute the Naturally Slim engagement announcements, such as non-starter follow-ups and mid-program results communication
- **Class Set-up** – launch the program as a 'class' with a specific start date and limited-time enrollment window versus on-demand model
- **Accountability** – include program completion language such as an incentive and/or penalty, valued greater than \$75. Enforcement is optional, and is the responsibility of the Client.

natura)(yslim®

Average results for Pay-for-Performance population

50-60% of participants will achieve 3% of body weight loss or greater¹

12.2 lbs average pounds lost per billed participant

-55% total metabolic syndrome reduction for billed population (3% of body weight loss or greater)¹

¹Published, peer reviewed clinical results at 20 weeks post-program from 3,880 participants at 93 employers.

¹Earnest, Conrad P., Church, Timothy S. Evaluation of Voluntary Worksite Weight Loss Program on Metabolic Syndrome. *Journal of Metabolic Syndrome & Related Disorders*, Volume 13, Issue 8, October 2015.

natura)(yslim®

Results based pricing: Pay-for-Performance

As a client of Wellmark, you only pay for the participants that measurably improve health with clinical significance:

- No longer have metabolic syndrome, or
- Lose a minimum 3% of body weight loss

No Implementation fee

No kit fee

No contract needed

Free consult and agreement on Engagement Best Practices

**You only pay for participants
with clinical health
improvement**

Federal Treatment Guidelines: How much weight loss is significant weight loss?

"...weight loss of as little as 3% to 5% is likely to result in clinically meaningful reductions in levels of triglycerides, blood glucose, and glycated hemoglobin and in the risk of developing type 2 diabetes..."

JAMA The Journal of the American Medical Association

Percentage of Body Weight Loss	Metabolic Syndrome Reversal Rate (N=1613)
3 - 5%	41.2%
5 - 7%	49.8%
7 - 9%	59.2%
≥ 9%	70.0%



JAMA January 1, 2014 Volume 311, Number 1

Ernest, C.P., et al. Journal of Metabolic Syndrome & Related Disorders. September 2015.

natura)(yslim®

Weight Loss Trend

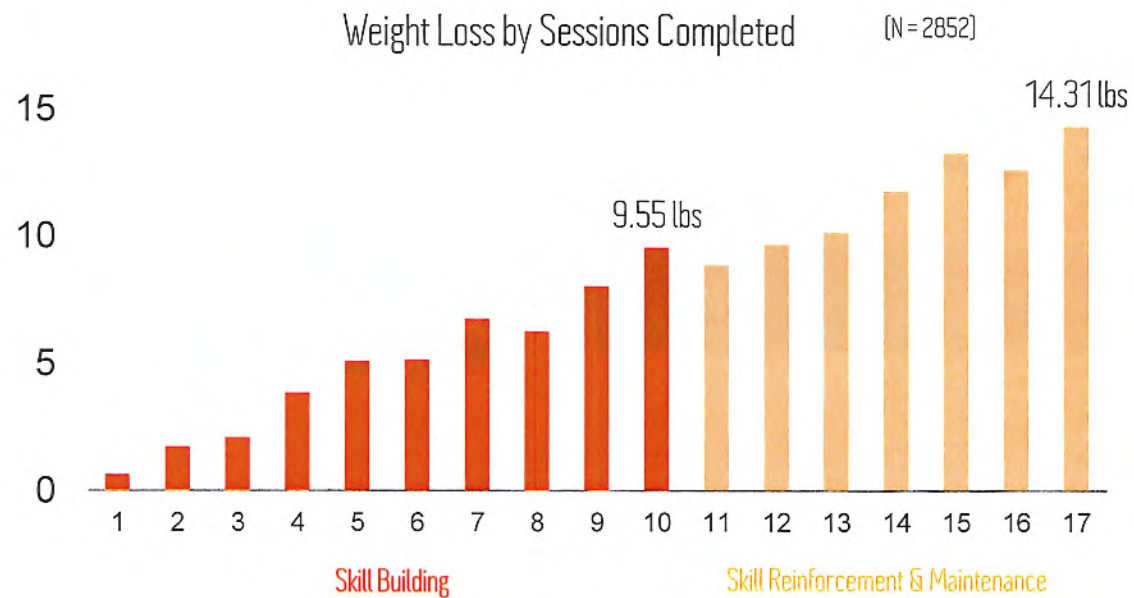

natura)(yslim®

Post Program: Custom Video Testimonials

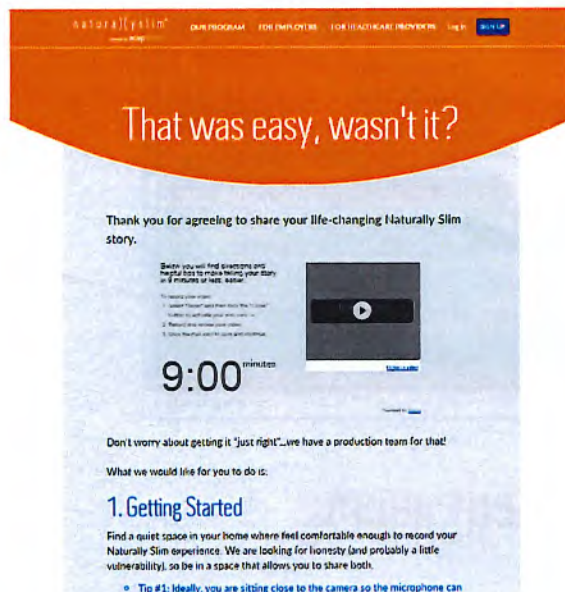

natura)(yslim®
OUR PROGRAM FOR EMPLOYERS FOR HEALTHCARE PROVIDERS HELP SIGN UP

That was easy, wasn't it?

Thank you for agreeing to share your life-changing I Naturally Slim story.

Share your real life experience with helpful tips to make being your story an inspiration to others.

1. Record your story.
2. Upload "Your" story then share "Your" story.
3. Upload to your website your story with...
4. Record your real life experience.
5. Upload your story to your website.

9:00 minutes

Don't worry about getting it "just right"...we have a production team for that!

What we would like for you to do is:

1. Getting Started

Find a quiet space in your home where feel comfortable enough to record your Naturally Slim experience. We are looking for honesty (and probably a little vulnerability), so be in a space that allows you to share both.

- Tip #1: Ideally, you are sitting close to the camera so the microphone can



natura)(yslim®

 THE TEXAS A&M UNIVERSITY SYSTEM

JEFF BOWEN
DIRECTOR, TECHNICAL OPERATIONS

Has lost 36 lbs. since starting Naturally Slim

Social Sharing & Counselor Support

NSTown™

Private, companion social networking site for groups, collaboration, discussion & support

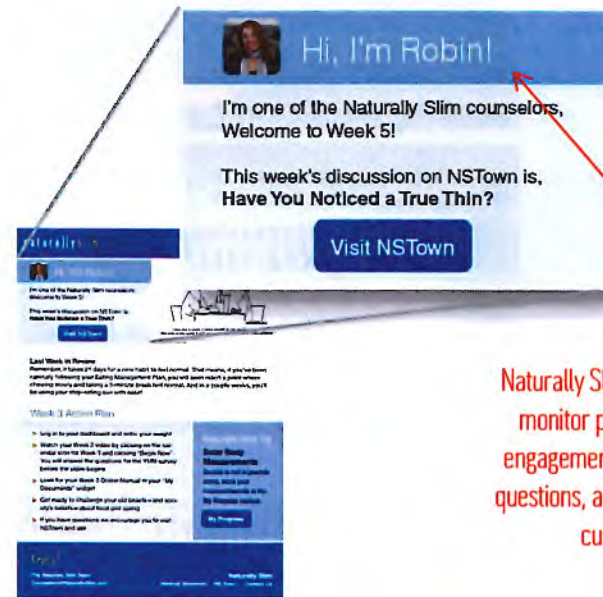

Naturally Slim counselors personally monitor participant progress and engagement, interacting, answering questions, and providing technology & curriculum support

Simple & Engaging User Experience

Participants must enter their weight before proceeding to the next lesson

Participants track goals with weight loss and physical activity with available syncing of 100+ eligible devices and wireless scales

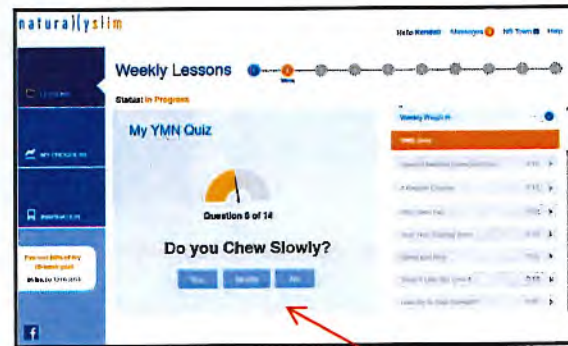

Skills and behaviors are re-enforced through weekly "Yes, Mostly, No" quizzes, which is also monitored by counselors for tailored support

Behavior change ecosystem



Program kit is shipped to the home, and includes a workbook to follow along, as well as tools needed for lessons in the curriculum

The participant engages on the ecosystem via computer or mobile device, completing their weekly sessions and applying the learned skills and behaviors

natura)(yslim®

Sample implementation timeline: 6–7 weeks (with biometrics)

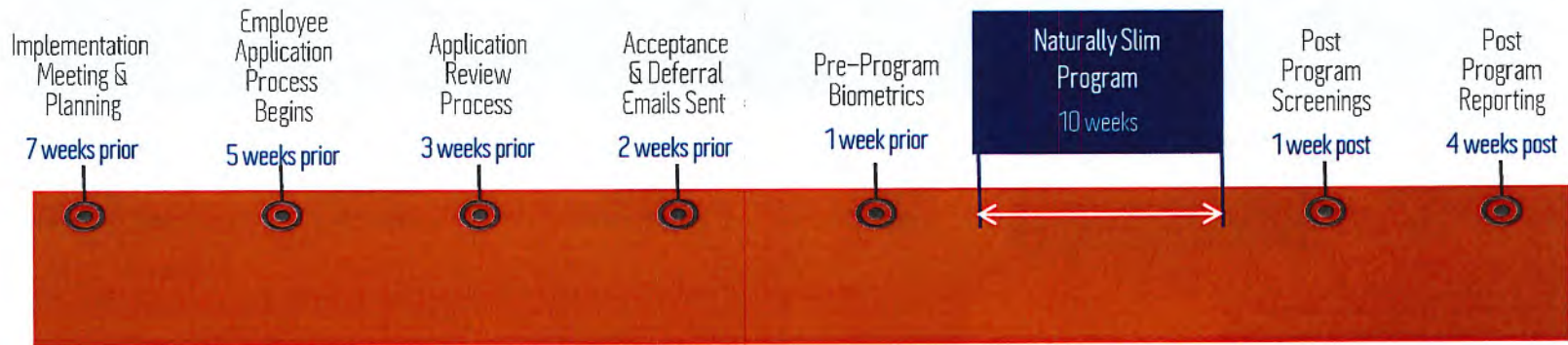

Approximately 10% of a broadly invited population will voluntarily apply for acceptance with the first invite.

natura)(y)slim®

Sample implementation timeline: 5-6 weeks



Approximately 10% of a broadly invited population will voluntarily apply for acceptance with the first invite.

natura)(yslim®

Simplicity & Scalability

For the employer and the participant

Step 1: Engagement



Step 2: Qualification



Step 3: Begin!



natura)(y)slim®

Meet the instructors

"It's not what you eat
but when and how you eat
that will help you lose weight."

-Marcia Upson, RN, MS, FNP-C
President, lead instructor



Marcia Upson

RN, MS, FNP-C
President, Naturally Slim

Lead instructor

Tim Church

MD, PhD, MPH
Chief Medical Officer, ACAP Health

200+ published studies

Todd Whitthorne

BS Kinesiology
President, ACAP Health

Physical activity expert

Georita Frierson

PhD
Behavioral Psychologist

Behavior modification and long-term maintenance

Dana Labatt

PhD
Clinical Psychologist

natura)(yslim®

Core Skills of Naturally Slim

Goal-Setting	Cognitive Behavioral Techniques
Self-Monitoring	Stress Management
Stimulus Control	Relapse Prevention
Modification of Eating & Activity Patterns	Problem Solving
Contingency Management	All delivered by clinical experts

natura)(yslim®

What about the Science?

Grounded in the
principles of the most
effective clinical
weight loss programs

(integrating principles from the DPP, Look Ahead &
Pounds Lost studies)

Contains vital teaching on behavioral principles such as problem solving, contingency management, & cognitive restructuring

Encourage self-monitoring of weight, food intake, behaviors & physical activity

Focuses on physical activity for weight loss, weight loss maintenance, & long-term quality of life

Includes one full year of weight loss instruction, counselor monitoring, & social support

Optimized specifically for metabolic syndrome reversal

Meets Federal Obesity Treatment Guidelines

natura)(yslim®

True Thin™ Philosophy



WHEN

Learning to recognize true hunger is the first step to better health.



WHAT

By learning when and how to eat, you can still enjoy all the foods you love.

- no pre-packaged foods to buy
- no points
- no restrictive guidelines



HOW

Learn how to make one serving feel as filling as a second helping, and do so naturally without restrictions.

natura)(yslim®

Retrain your brain. And your body.

This simple, online program is based
on new understandings of what thin
people do naturally.



natura)(yslim®

Program Demo



Just a taste from 650+
corporate clients:



natura)(yslim®

The Hartford | Total Pounds Lost: **40,000**

"The best thing about the program is that it is not a diet, but most definitely a lifestyle change. Nothing to start and stop – Naturally Slim is forever."

– Harriet Aaronson Assistant Vice President

Southwest Airlines | Total Pounds Lost: **17,500**

"More than anything, the program seems to empower participants to live healthier – they get to own their journey."

– Kembre Roberts Wellness Manager

Genesis Health System | Total Pounds Lost: **35,000**

"We launched this wellness program to control our costs and avoid the alarming trend of double-digit percentage increases in healthcare costs, we never expected to save millions of dollars or experience a negative investment."

– Doug Cropper President & CEO

Baylor Scott & White | Total Pounds Lost: **20,000**

"We've had 1600 employees go through the program and to date have lost close to 20,000 pounds over that time frame and that's just during the program itself. We know the employees are still losing weight after the program."

– Leia Spoor Director of Health & Wellness

natura)(yslim®

Financial Results at  **GENESIS**

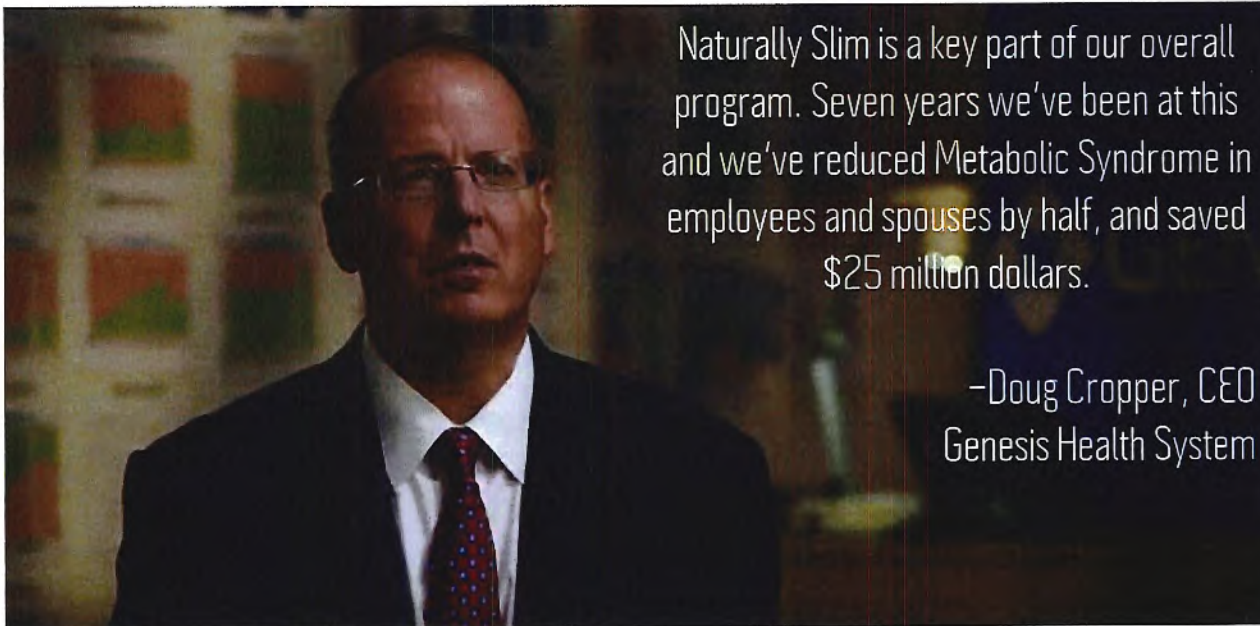

Naturally Slim is a key part of our overall program. Seven years we've been at this and we've reduced Metabolic Syndrome in employees and spouses by half, and saved \$25 million dollars.

-Doug Cropper, CEO
Genesis Health System

natura)(yslim®

Sustainable Metabolic Syndrome Reversal at

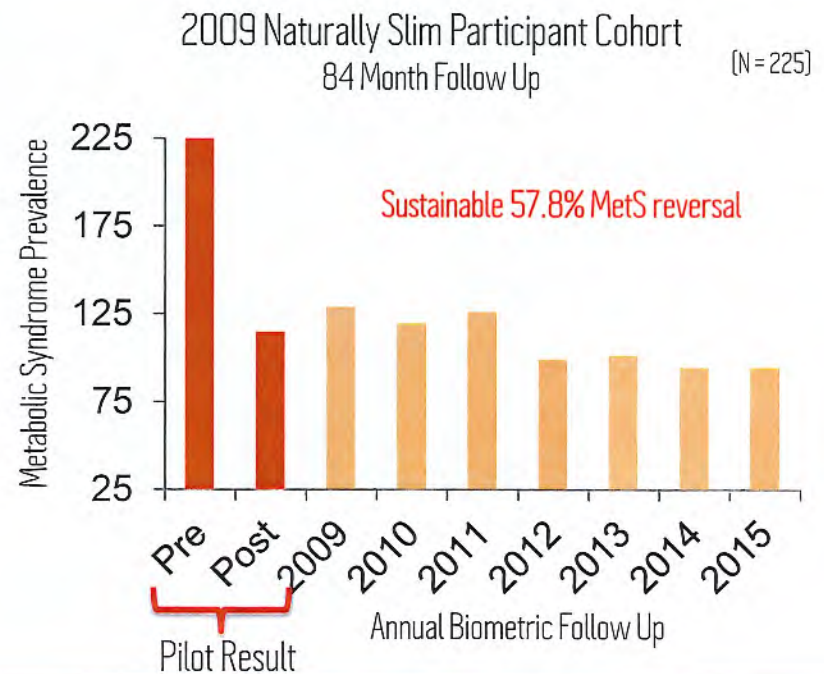
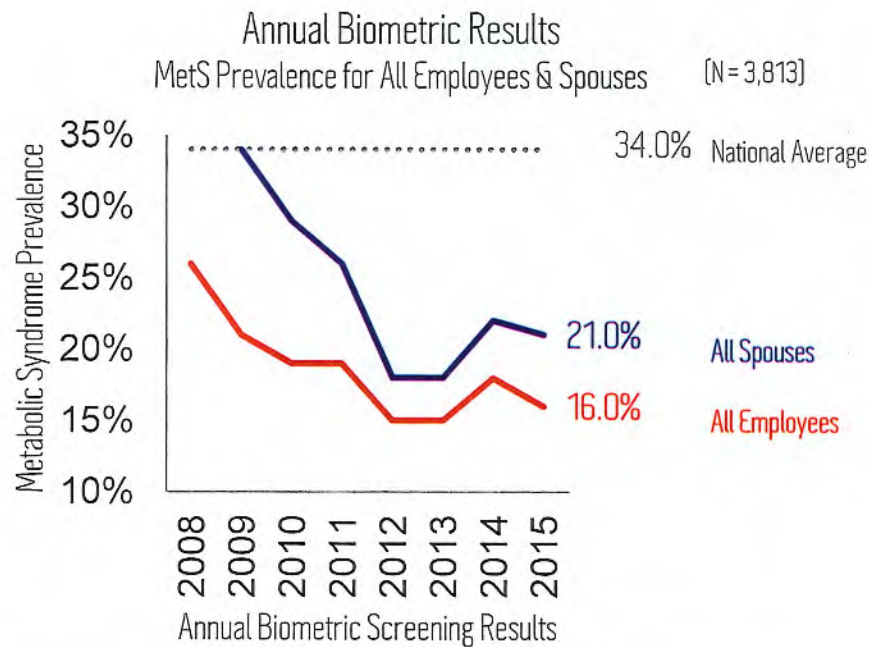

Companywide Metabolic Syndrome Reversal at Manufacturing Corporation

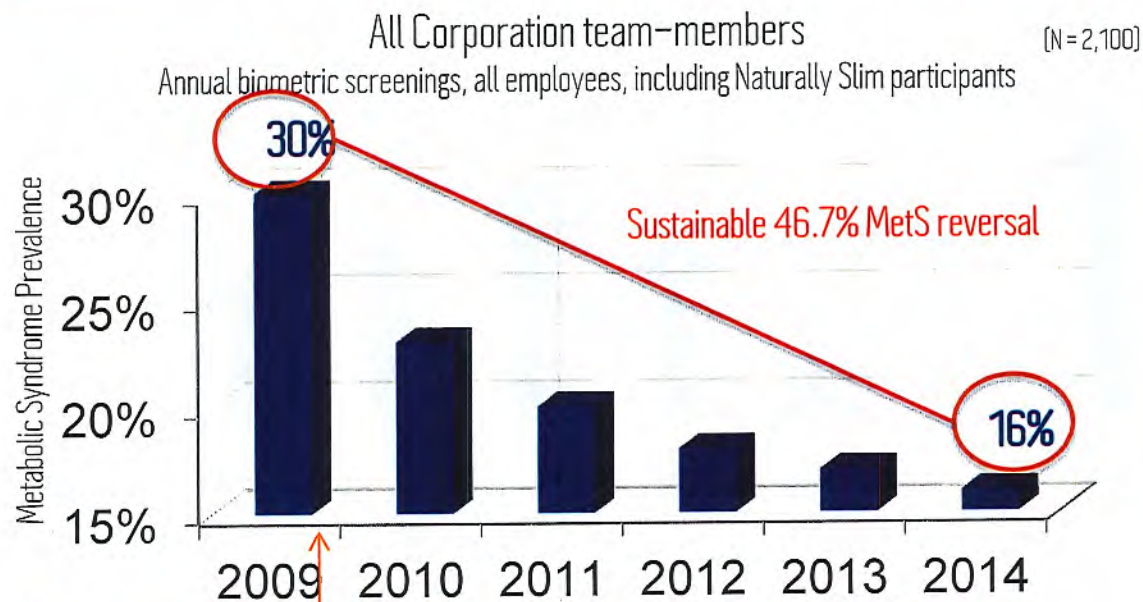

Corporation rolled out Naturally Slim to their entire population beginning in 2010.

Metabolic syndrome prevalence is now less than half the national average of 34% adult prevalence.

natura)(ySlim®

The blood does not lie...

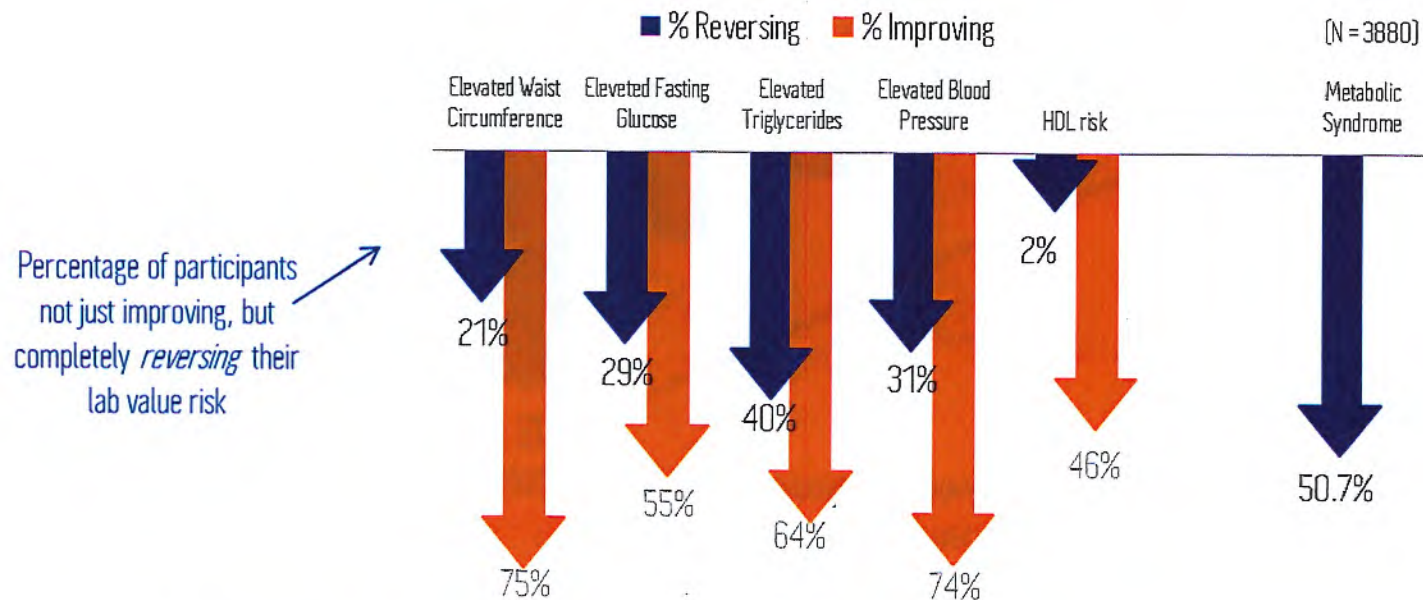

¹Published, peer reviewed clinical results at 20 weeks post-program from 3,880 participants at 93 employers.

¹Earnest, Conrad P., Church, Timothy S. Evaluation of Voluntary Worksite Weight Loss Program on Metabolic Syndrome. *Journal of Metabolic Syndrome & Related Disorders*, Volume 13, Issue 8, October 2015.

natura)(yslim®

The blood does not lie...

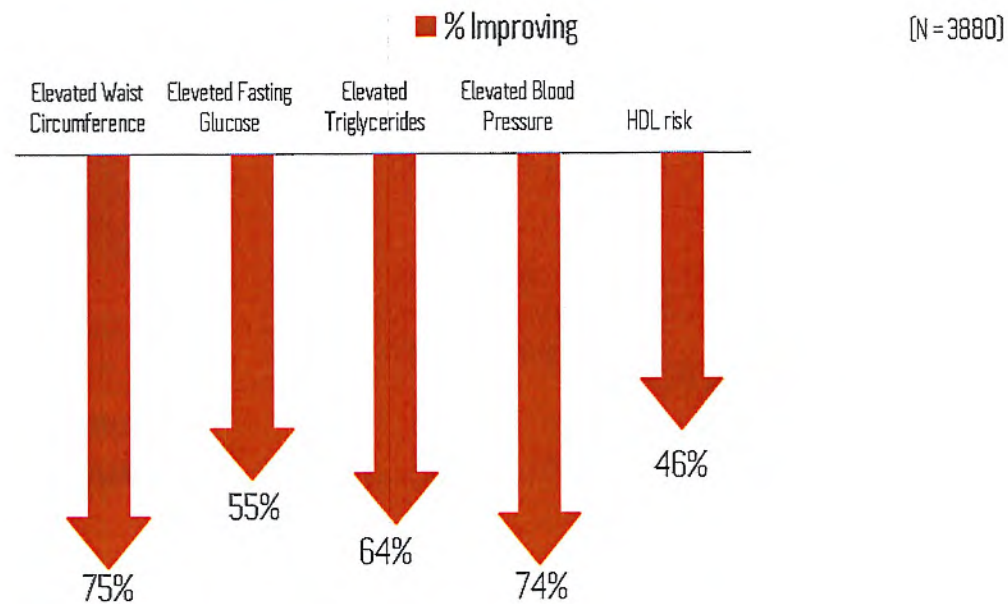

¹Published, peer reviewed clinical results at 20 weeks post-program from 3,880 participants at 93 employers.

¹Earnest, Conrad P., Church, Timothy S. Evaluation of Voluntary Worksite Weight Loss Program on Metabolic Syndrome. *Journal of Metabolic Syndrome & Related Disorders*, Volume 13, Issue 8, October 2015.

natura)(yslim®

Clinically proven, peer-reviewed, and published health outcomes

Metabolic Syndrome and Related Disorders

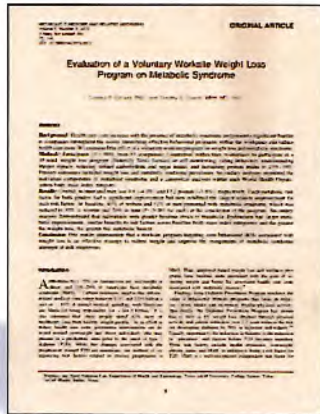

50.7%

of participants with MetS
reversed their
condition

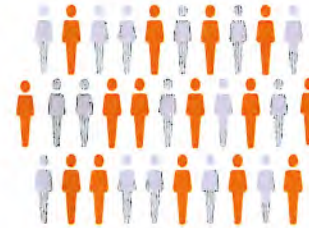

10.6 lbs

of average per participant
weight loss



¹Published, peer reviewed clinical results at 20 weeks post-program from 3,880 participants at 93 employers.

¹Earnest, Conrad P., Church, Timothy S. Evaluation of Voluntary Worksite Weight Loss Program on Metabolic Syndrome. *Journal of Metabolic Syndrome & Related Disorders*, Volume 13, Issue 8, October 2015.

natura)(yslim®

Naturally Slim Summary of Value

- Guaranteed lab risk reversal to metabolic syndrome, diabetes prevention, and weight loss
- Exclusive Pay-for-Performance for Wellmark customers—"clinical results don't improve, you don't pay"
- Proven "skill-building" curriculum from latest behavioral research for sustainable behavior modification
- Online delivery via behavior change ecosystem for simple, convenient, and private user experience
- Turnkey implementation model with full administrative support and reporting by acap health
- Fully scalable and effective for all employer industries and population sizes
- Meets latest federal obesity treatment guidelines

natura)(y)slim®

Naturally Slim is a clinically proven, online behavioral weight loss solution that is guaranteed to measurably reverse metabolic syndrome and prevent diabetes in populations.



Disease Risk Associated with Metabolic Syndrome

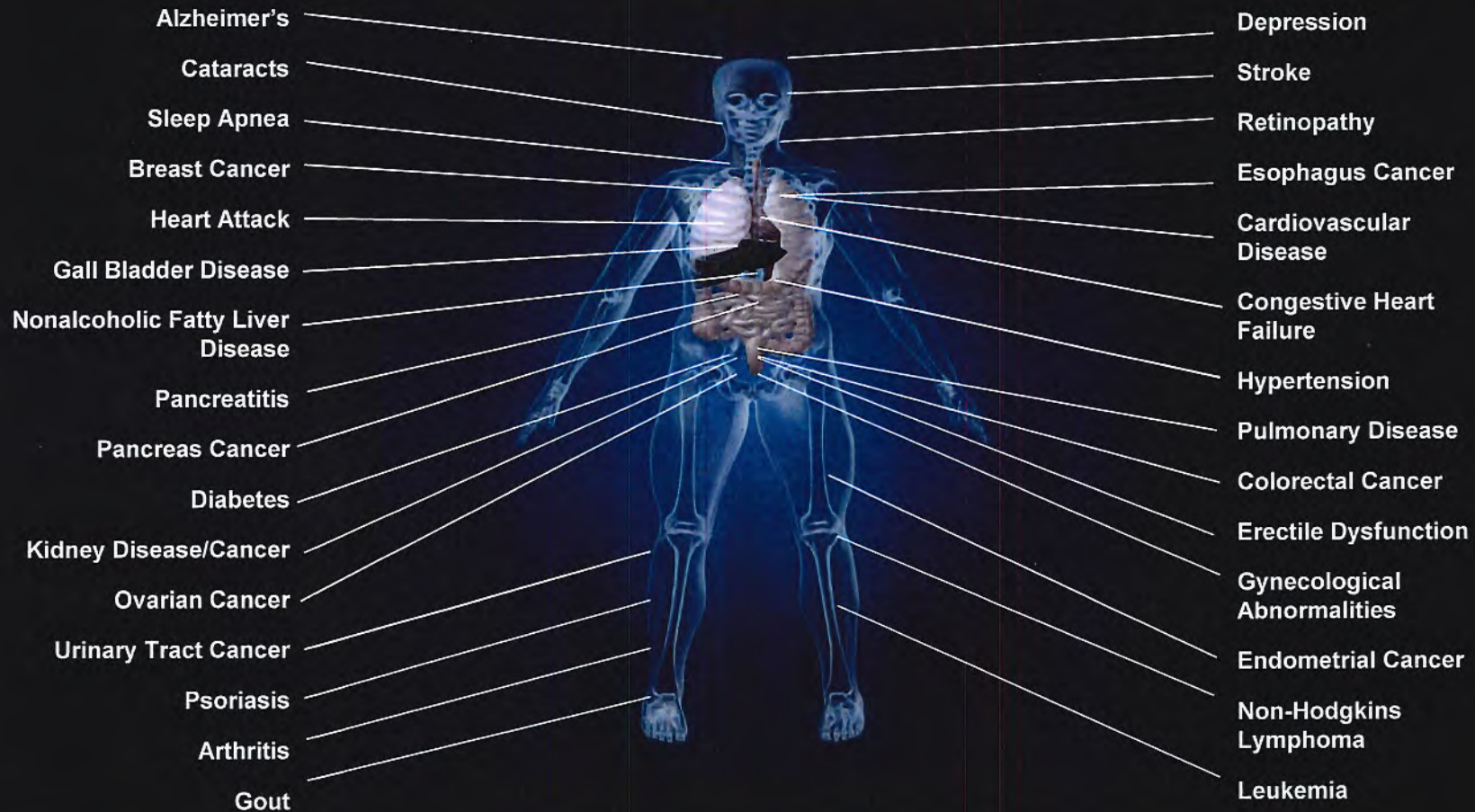

Metabolic Syndrome financial impact

Current Costs

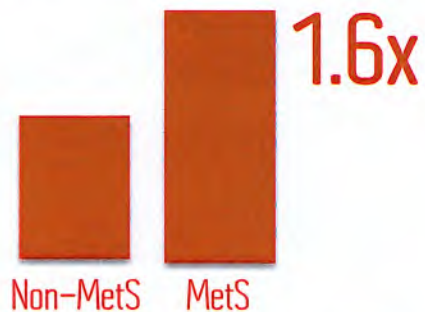

plan members with metabolic syndrome average 60% more annually in healthcare costs as those without metabolic syndrome¹

Future Costs

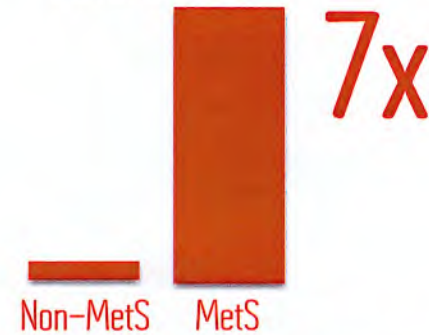

plan members with metabolic syndrome have a 700% greater likelihood of having a high-cost claim in next three years when compared to the population without metabolic syndrome²

¹Fitch, K., Pyenson, B., & Iwasaki, K. Milliman Actuarial. (2007). Metabolic syndrome and employer sponsored medical benefits: an actuarial analysis. *Value in health*, 10(s1), S21-S28.

¹Boudreau DM, Malone DC, Raebel MA, et al. Health care utilization and costs by metabolic syndrome risk factors. *Metab Syndr Relat Disord* 2009; 7:305-314.

²ACAP Health Consulting

Where do next year's high cost claimants come from?

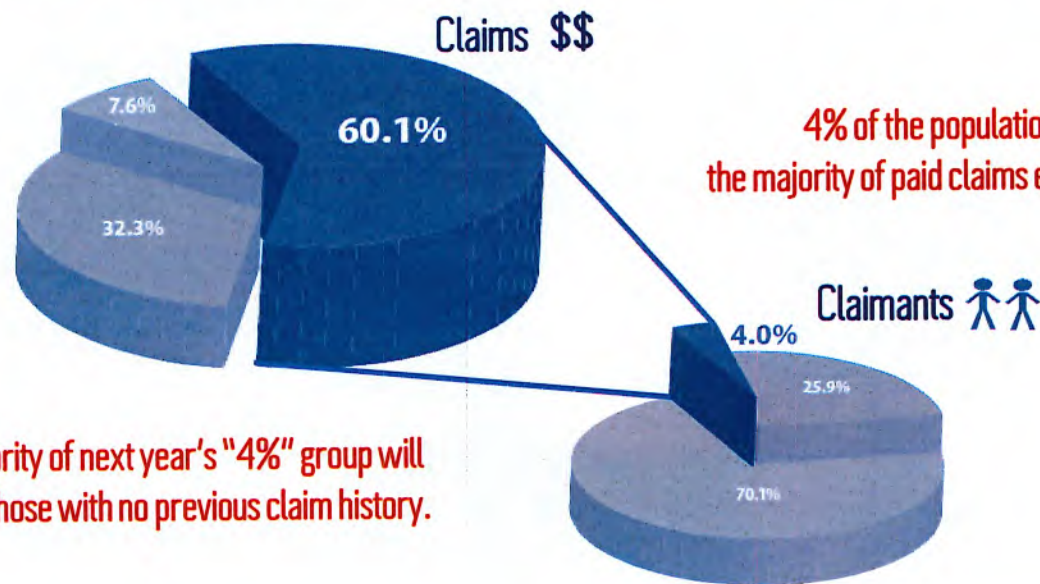

4% of the population drive the majority of paid claims each plan year,

but the majority of next year's "4%" group will come from those with no previous claim history.

Metabolic syndrome
(MetS) is a combination of
**3 OR MORE
RISK FACTORS**
that increase the likelihood
of heart disease &
diabetes.

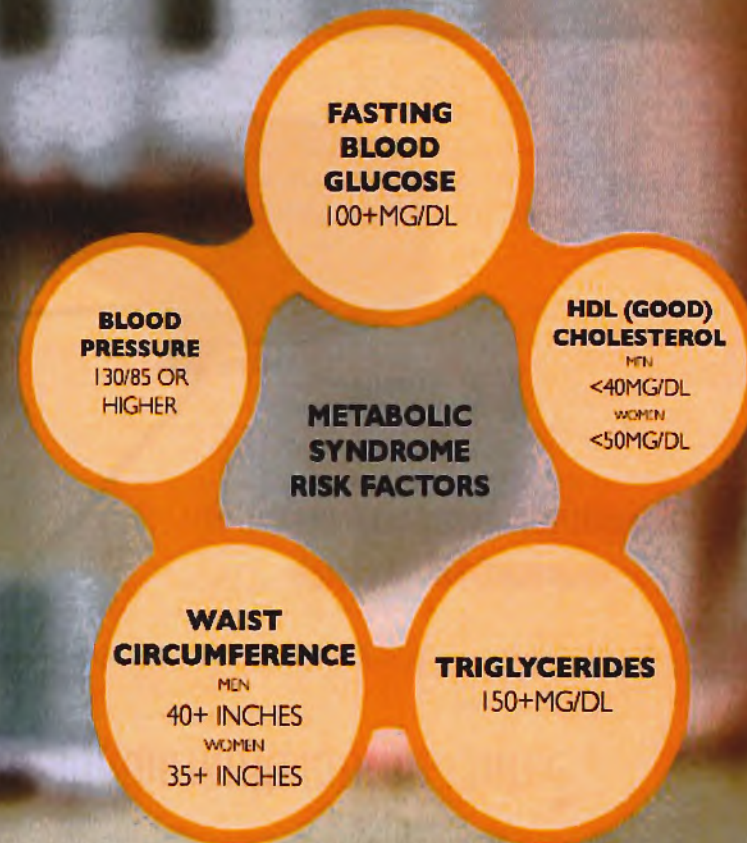

Diabetes and Comorbid Cost Impact

Diabetes		Cardiovascular
Musculoskeletal		Cancer

Individuals with diabetes cost at least **2.3X** more than an individual without diabetes, associated with an additional **\$7,900** in average annual medical costs¹

¹ American Diabetes Association. Economic costs of diabetes in the U.S. in 2012. Diabetes Care 2013;36(4):1033–46. Erratum in: Diabetes Care 2013;36:1797.

natura)(yslim®

Diabetes and Comorbid Cost Impact

Diabetes	Cardiovascular
Musculoskeletal	Cancer

natura)(ySlim®

Our business is preserving birthdays

The not-a-diet online metabolic syndrome reversal and weight loss program that is changing lives and measurably improving corporate bottom lines.

Your Team

Todd Whitthorne | President
Tim Church, MD, PhD, MPH | CMO
Wally Goma MHA/MBA | CEO

Kendall Ramirez | Director, Engagement
Austin Wilcox | Director, Product & Business
Nikki Thaden | Senior Consultant

natura)(ySlim®

More than one in three Americans is on the Diabetes Escalator™

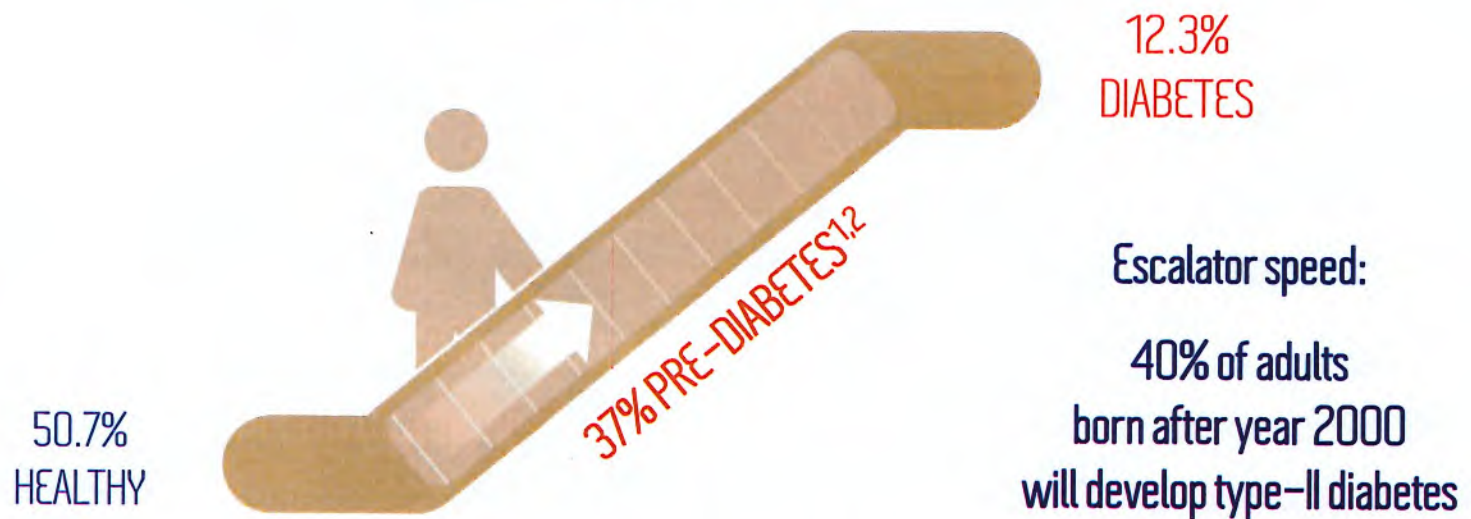

¹Escalator speed: 15–30% of pre-diabetic adults will develop type-II diabetes within the next 5 years

²Over 90% of pre-diabetics do not know they have pre-diabetes

The Problem

In America, 37% of people have pre-diabetes (90% of which don't know they are pre-diabetic). Without intervention, 15-30% of pre-diabetic adults will develop type-2 diabetes within the next five years. It is also predicted that 40% of adults born after the year 2000 will develop type-2 diabetes.



¹Escalator speed: 15-30% of pre-diabetic adults will develop type-II diabetes within the next 5 years
²Over 90% of pre-diabetics do not know they have pre-diabetes

The Financial Problem

- Plan members with metabolic syndrome average 60% more annually in healthcare costs as those without metabolic syndrome¹
- Future high cost medical claimants were 7X higher for individuals with Metabolic Syndrome
- Individuals with diabetes cost at least 2.3X more than an individual without diabetes, associated with an additional \$7,900 in average annual medical costs

¹Fitch, K., Pyenson, B., & Iwasaki, K. Milliman Actuarial. (2007). Metabolic syndrome and employer sponsored medical benefits: an actuarial analysis. *Value in health*, 10(s1), S21-S28.

Executive Summary

The focus of our recommended strategy with Woodbury County is to measurably slow the production of new disease by clinically improving the health of your population prior to the **occurrence** of a high cost claim event. Approximately 5% of any employee population is responsible for 50% of the medical claims in a given year. The majority of next year's high-cost claimants do not have markers of risk present in the medical and pharmacy claims history. Instead, their future disease risk is predicted through health risk clusters known as Metabolic Syndrome (MetS):

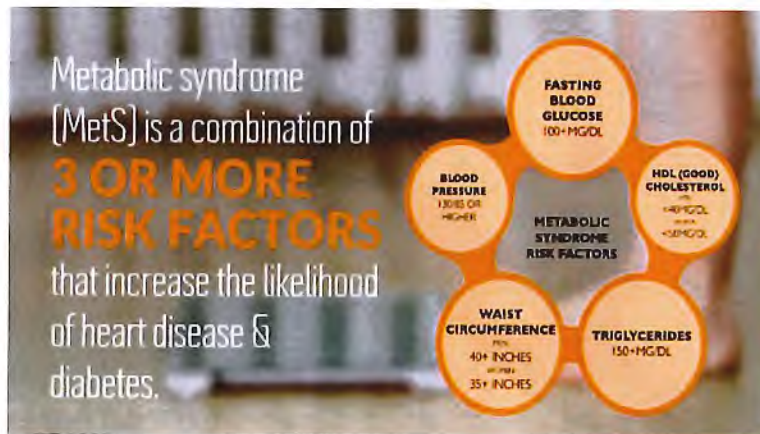

Metabolic Syndrome financial impact



But there is good news—together, we can effectively eliminate future claim risk and improve the quality and quantity of your employees lives with an intervention that is quick, turnkey, and has a proven track record of sustainable results with similar populations. Naturally Slim® is an online, behavior modification program proven to deliver sustainable weight loss and reverse obesity, pre-diabetes, and MetS. It has been successful in helping hundreds of companies reverse the incidence of MetS of their employees – by over 50% on average. And even better news—its guaranteed.

The Results

- 50.7 reversal of Metabolic Syndrome
- 29% reversal rate of pre-diabetic and diabetic risk
- 10.6 pound weight loss on average at 10 weeks
- 5.2% of sustained body weight lost at 12 months after completion

50.7%
of participants with MetS
**reversed their
condition¹**

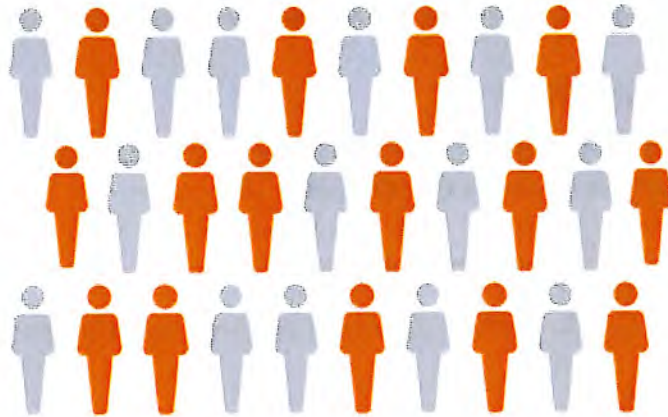

¹Published, peer reviewed clinical results at 20 weeks post-program from 3,880 participants at 93 employers.

¹Earnest, Conrad P., Church, Timothy S. Evaluation of Voluntary Worksite Weight Loss Program on Metabolic Syndrome. *Journal of Metabolic Syndrome & Related Disorders*, Volume 13, Issue 8, October 2015.

The Financial Results

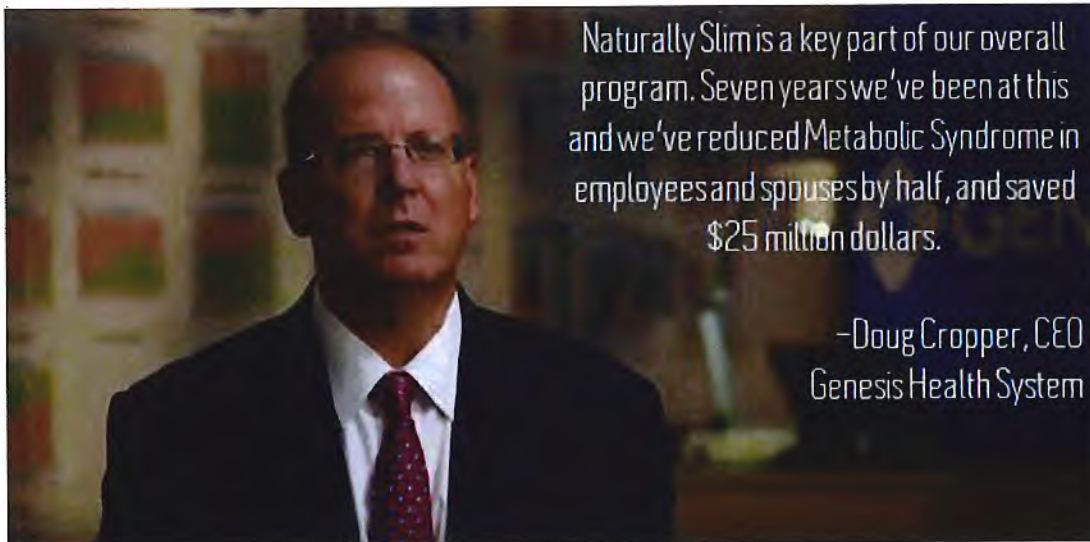

Naturally Slim is a key part of our overall program. Seven years we've been at this and we've reduced Metabolic Syndrome in employees and spouses by half, and saved \$25 million dollars.

—Doug Cropper, CEO
Genesis Health System

The Solution (Naturally Slim)

Measurable Results

- The Naturally Slim program generates measurable & sustainable clinical lab improvements and weight loss

Pay for Performance

- As a client of Wellmark, you only pay for the participants that measurably improve health with clinical significance

Based on Best Clinical Science

- Behavior modification based on skill-building, not dieting, is clinically-proven to be the most effective & sustainable method for weight loss and health improvement.

Meets Federal Obesity Treatment Guidelines

- Satisfies the Affordable Care Act's requirement for obesity counseling with a turnkey, high-value, proven solution.

Scalable and Accessible

- Because Naturally Slim is delivered online via our proprietary eLearning Management System, it is fully scalable regardless of the size, geographic dispersion or office concentration of your employee population.

Turnkey

- The program is quick & easy for your human resources team to implement. A 60 minute kick-off call is all that is needed to begin implementation.

Full Implementation & Ongoing Support

- You will get full implementation and ongoing support from a dedicated project engagement team along with customized employee communications and best practice consulting.

Proprietary Onboarding & Engagement Model

- We understand how to engage users and motivate behavior to deliver results. In fact, 77% of participants maintain their weight loss or continue to lose weight years after graduation.

Naturally Slim

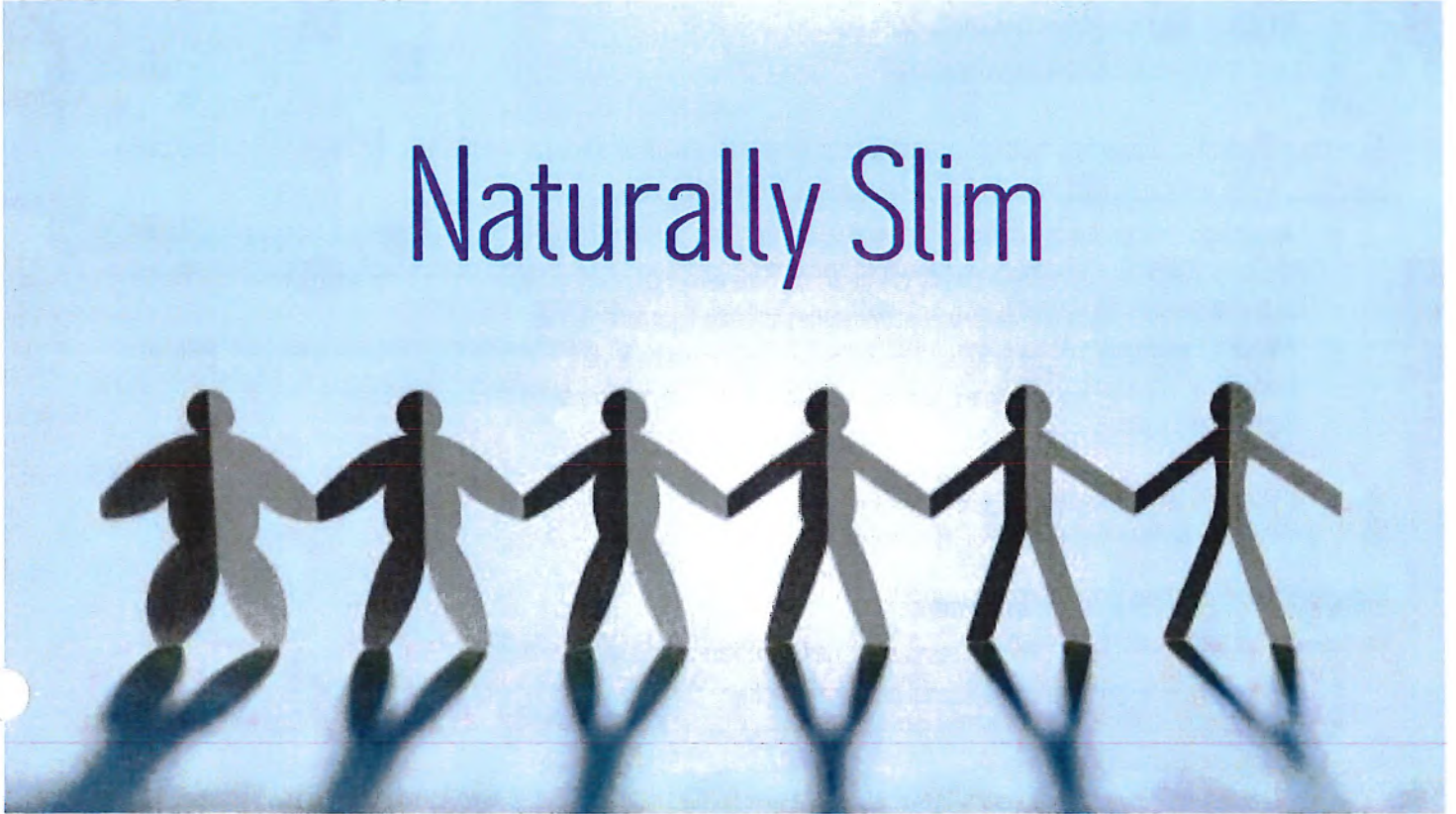

Pricing

As a client of Wellmark, the initial cost is \$0. The client only pays for the participants that measurably improve health with clinical significance:

- No longer have metabolic syndrome, or
- Lose a minimum 3% of body weight loss

Once the individual no longer has metabolic syndrome or loses a minimum of 3% body weight loss, the client will be invoiced a one-time, \$595 per participant fee, as part of the monthly Wellmark services.

- *Weight Loss*– weight loss percentages will be measured with system collected data at the end of each phase of the program (Foundations, NS4You and NS4Life). Woodbury County will be invoiced the remainder of the program cost for each participant that reaches and/or surpasses 3% of their body weight lost at the end of the Foundation phase.
- *Metabolic Syndrome*– if post program biometrics are used for measurement in addition to weight loss when post-program biometric screenings are completed, Woodbury County will be invoiced for any participant that reverses their MetS at the end of the Foundation phase.

- ❖ No Implementation Fee, No Kit Fee, No Contract Needed
- ❖ Free consult and agreement on Engagement Best Practices

Engagement Best Practices [pay-for-performance]

For pay-for-performance pricing, Client agrees to ACAP Health best practices engagement model:

- *Announcement*– communicate via email to a broad employee population, not targeted to at-risk employees
- *Engagement*– distribute the Naturally Slim engagement announcements, such as non-starter follow-ups and mid-program results communication
- *Class Set-up*– launch the program as a 'class' with a specific start date and limited-time enrollment window versus on-demand model
- *Accountability*– include program completion language such as an incentive and/or penalty, valued greater than \$75. Enforcement is optional, and is the responsibility of the Client.

Additional Considerations [pay-for-performance]

- *Kit Fee*– will launch program with kit fee being waived for Wellmark clients, TBD for future consideration.
- *Weight Loss*– weight loss percentages will be measured with system collected data at the end of each phase of the Naturally Slim program (Foundations, NS4You and NS4Life). Woodbury County will be invoiced the remainder of the program cost for each participant that reaches and/or surpasses 3% of their body weight lost at the end of the Foundation phase.
- *Metabolic Syndrome*– if post program biometrics are used for measurement in addition to weight loss when post-program biometric screenings are completed, Woodbury County will be invoiced for any participant that reverses their MetS at the end of the Foundation phase.

Acknowledgement of following implementation and best practices for Pay-for-Performance pricing model:

Signature: _____

Date: _____

User Experience

Learn

The Learn page is where users will view the curriculum in the Naturally Slim program. From this page, the user can view their lessons, complete their quizzes and download the accompanying weekly manual and food diary. Each week beginning in Week 2, users will start their week with the Yes/Mostly/No quiz. This quiz assesses whether the user is putting the skills they learn to use. Feedback from the quiz is tailored to the user's responses in an effort to boost adherence and foster weight loss.



Progress

The My Progress page allows users to track their weight loss progress. Weekly weigh-ins are required before viewing the next week's lessons however daily weigh-ins are encouraged because research shows that frequent monitoring of weight improves weight loss results. On the My Progress page, users can also log and track their steps and activity to verify they are completing the recommended amount. Activity doesn't drastically affect weight loss but making activity a habit is important since activity is vital to weight maintenance.

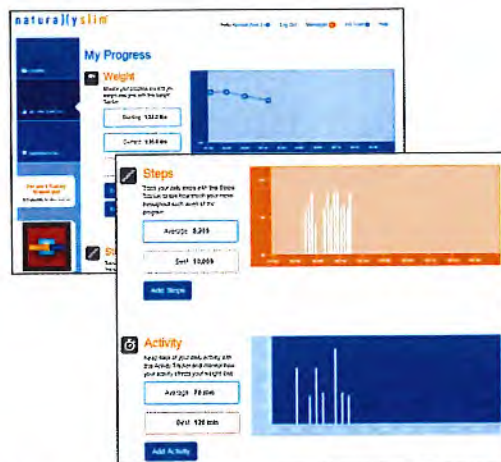

Users can either input their steps and activity or they can sync Naturally Slim with their personal activity device such as FitBit® and JawBone®.

The Naturally Slim Experience

The Naturally Slim user experience is based on learnings from the best clinical behavioral weight loss programs including self-monitoring and social support. The program is delivered via a proprietary eHealth technology platform leveraging the latest in behavior change science. Participants watch video coaching delivered by our five subject matter experts.

Along with the video segments, the program includes quizzes for retention purposes and our proprietary Yes/Mostly/No behavioral skill-building exercises.



Participants can access the learning dashboard through any electronic device with Internet connectivity including desktop, laptop, tablet or smartphone which makes the program easy to incorporate into their everyday life. The Naturally Slim program is integrated with both FitBit® and JawBone® activity devices so participants can keep track of their activity, steps and weight through those devices or directly through the Naturally Slim dashboard.

Naturally Slim Foundations

During the initial skill-building phase of Naturally Slim, known as Foundations, participants receive new counseling videos each week for ten weeks. Participants have 10-days to view each weekly course before the course expires. During the 10-day period participants can stop and start their course and may also re-watch a lesson during that time period for reinforcement.

A high-level overview of the curriculum is as follows:

Class One:

- Introduction of the Naturally Slim team
- Naturally Slim principles and skills
- Recognize the difference between hunger & appetite
- Stimulus control, i.e. set up an eating management plan
- Medical considerations before starting a weight loss program
- Health benefits of losing 5%+ of your body weight

Class Two:

- Importance of Stop Eating Cues to prevent eating past comfort level
- Brain perception of taste vs. hunger
- The importance of food diaries
- Introduction to physical activity
- National Weight Loss Registry statistics on habits of successful dieters

Class Three:

- Understand Vital Needs – the needs, other than hunger, that cause us to eat
- Our supersized culture and the incidence of mindless eating
- Goal setting and problem solving
- Benefits and tips for getting started with physical activity

Class Four:

- Hidden sugar in today's diet, including drinks
- The effect of sugar on the body and weight loss
- High-fructose corn syrup
- Mindful activities and finding time to exercise
- Macronutrient-focused weight loss and energy balance

Class Five:

- Nutrition 101 – balancing protein, carbohydrates and fats
- Simple vs. complex carbohydrates
- Types of fats (omega-3/omega-6/trans-fat)
- Stress management and coping responses
- Physical activity's effect on health and weight maintenance

Inspiration

The Inspiration page contains multiple tools to help keep users engaged in the program using gamification, motivational tools, and feedback.



Some examples of the tools on the Inspiration page include:

- Success Stories allow users to share their inspirational stories of how Naturally Slim has helped them lose weight and start down a new path of healthier living. These stories are fun for the participant to share but also great motivation for others just starting the program.
- Vital Needs are an important topic covered in the curriculum and our Vital Needs widget allows users to determine their own Vital Needs as well as manage them on-going to help ensure their Needs are met.

NS Town

NS Town is the Naturally Slim online social support community where current users and alumni can interact with each other as well as counselors. They can get questions answered, post comments and watch additional videos to further enhance their experience in the Naturally Slim program.



NS4You™ and NS4Life™

The core principles of the Naturally Slim program are taught in the first 10 weeks in the skill-building portion of the program, Foundations. However, research shows that skill reinforcement is needed over time to ensure that participants truly learn the skills and learn how to apply those skills into their lives. In fact, the Federal Obesity Treatment Guidelines state that an ideal lifestyle intervention program would include 14 or more counseling sessions in six months with subsequent counseling for one complete year of intervention.

Based on this guidance as well as research that proves that weight loss increases with additional counseling, the Naturally Slim program includes two additional phases after the initial 10-week Foundations program totaling 23 sessions for a full year of behavior counseling and support.

NS4You – Skill Reinforcement

NS4You consists of seven classes delivered biweekly over the course of 14 weeks. Videos are approximately 25 minutes in duration and provide reinforcement of the skills learned in Foundations. Topics include a review of the 17 core principles of Naturally Slim, problem solving, Vital Needs/emotional eating, benefits of physical activity and avoidance of sedentary behavior, relapse prevention/saboteurs, and weight loss maintenance. The lessons are presented in a roundtable format with various combinations of:

- Marcia Upson, RN, MS – lead educator and the face of Naturally Slim
- Tim Church, M.D., M.P.H., Ph.D. – national expert on obesity & weight loss science
- Dana Labat, Ph.D. – clinical psychologist
- Todd Whitthorne, BS Kinesiology – subject matter expert on physical activity

During the 14 weeks of NS4You, participants will continue to have access to the online dashboard 24/7, will receive an email alerting them when new content available and will have two weeks to complete each lesson.

NS4Life – Skill Maintenance

NS4Life follows NS4You and consists of six classes, delivered monthly for six months, and is focused on helping participants maintain the skills previously introduced in Foundations and NS4You. Each lesson is presented in a conversational interview format which helps the material feel less like a 'lesson' and more like familiar information with new hints on how to apply it. Many of the same topics are discussed along with a review of the medical benefits to weight loss and what the research shows regarding metabolism and physical activity. Additionally, NS4Life includes testimonials from past participants, including physicians.

The combination of Foundations (10 sessions), NS4You (7 sessions) and NS4Life (6 sessions) totals 23 sessions over the course of one year, which exceeds the Federal Obesity Guidelines.

Class Six:

- Weight fluctuations
- Food cravings vs. easily accessible food
- Maintaining-weight portions versus losing-weight portions
- Recognizing and satisfying Vital Needs
- Doctor's clearance for physical activity
- Centers of Disease Control (CDC) exercise recommendations

Class Seven:

- Emotions and their role in eating
- Recognizing true feelings
- Cognitive Restructuring
- Importance of self-monitoring
- Making exercise a habit
- Diabetes

Class Eight:

- Naturally Slim principles in real life situations, e.g. travel, parties, eating out
- Grocery shopping and meal-planning
- American culture vs. cultures in other countries
- Metabolic syndrome and its risk factors
- Setting and monitoring activity goals
- Cognitive behavioral techniques

Class Nine:

- Pleasure vs. Happiness
- Understanding serving sizes
- Longevity, long-term healthfulness and social support
- Conventional wisdom vs. weight loss science
- Dealing with saboteurs

Class Ten:

- Review of Naturally Slim principles and tools
- Weight loss motivation
- Maintaining motivation & eliminating excuses
- Long-term action plan and contingency management
- Quality of Life & impact of physical fitness on life

Timeline

The standard implementation timeline is 4–6 weeks in duration. Six weeks ensures enough time to finalize communications, organize biometric screenings (optional), allow employees to apply, etc. The Implementation meeting (Client Implementation Questionnaire (CIQ) meeting) begins the process to customize the program. Agenda items of this meeting include participation and acceptance criteria, communication strategy planning, course completion and incentive model, program parameters, and timeline. Below is a high level overview of the 6 week implementation timeline. A sample detailed timeline is provided on the following page.

Sample implementation timeline: 5–6 weeks



Implementation

Our goal is to make implementation of Naturally Slim quick and easy for Woodbury County. ACAP Health provides full implementation and administrative support. From launching the program with hundreds of other companies, we've learned what you need in order to make Naturally Slim simple to implement. Therefore, our implementation support includes:

- Implementation planning and scheduling
- Customized employee communications and presentations
- Consulting on best practices for program engagement
- Integration of your lab data into our measurement platform
- Development of custom online participant application
- Participant acceptance & deferral processing
- Post-program reporting of weight loss and biometric results
- Post-program survey for participant feedback
- Executive level summary reporting presentation
- Long-term cohort and benchmark reporting

Step 1: Engagement



Step 2: Qualification



Step 3: Begin!



Communication

As part of your roll-out of Naturally Slim, we offer a complete suite of communication materials that can be customized for Woodbury County. Utilizing these materials helps ensure that your roll-out is turnkey but also ensures that communication is consistent, on-brand and most importantly, effective. The suite of materials includes numerous different themes so you can choose the theme that best fits your employee population. Plus, there are numerous options for communication format including flyers, digital banners, email announcements, direct mail pieces, brochures and more.

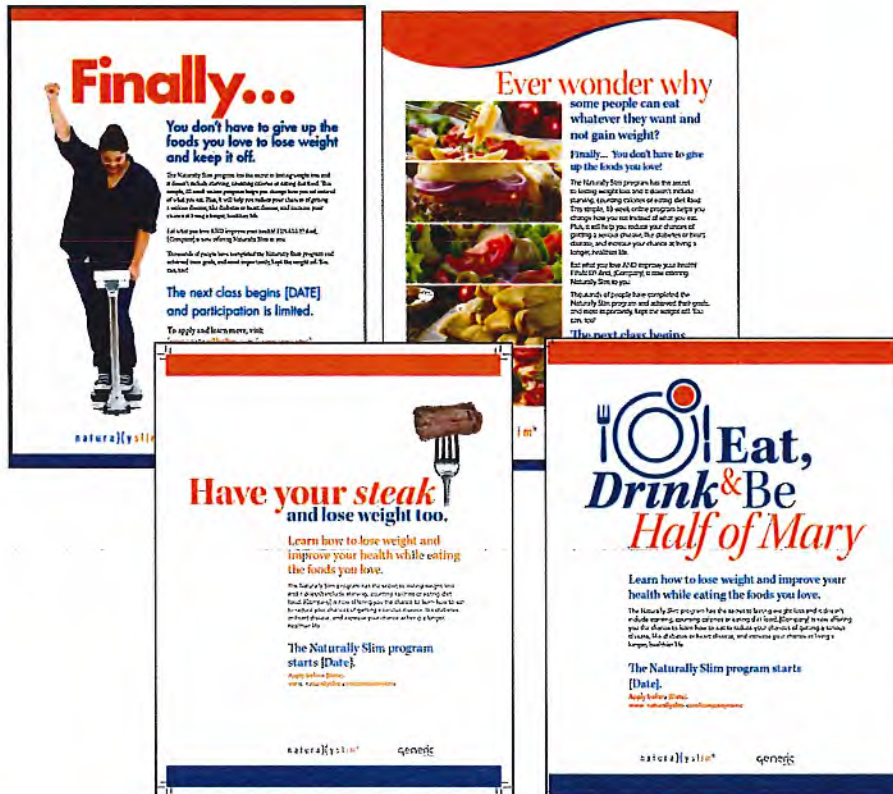

Additionally, with our experience launching Naturally Slim throughout hundreds of other companies, we can provide consulting on what has worked and what hasn't worked (communication timing, channels used, etc.) to help ensure your roll-out is as effective as possible.

Sample Detailed Timeline

Major Milestone	Timing	Assigned To
Client Implementation Questionnaire meeting	Week of July 20, 2015	ACAP/Client
Application creation	Week of July 20, 2015	ACAP
Testing of application	Before July 29, 2015	ACAP/Client
Drafting of communication announcement & pilot program solicitation	Week of July 20, 2015	ACAP/Client
Final Program announcement communication due to ACAP	By July 30, 2015	Client
Program announcement electronic communication	August 3, 2015	Client
Implementation		
Online application/registration begins	August 3, 2015	ACAP
Reminder Email Communication	August 11, 2015	Client
Application closing electronic reminder, if necessary	August 14, 2015	Client
Online application/registration concludes	August 14, 2015	ACAP
Applicant review process	August 17-18, 2015	ACAP
Acceptance list sent for approval (if requested)	By COB August 18, 2015	ACAP
Client approval of acceptance list (if requested)	By August 20, 2015	Client
Accept/Defer communication sent to program applicants	August 21, 2015	ACAP
Kit shipped to participant	August 24, 2015	Naturally Slim
Biometric screenings, if applicable	By Kick-off Date	Client
Delivery		
Program "kick-off" session (week one class starts)	August 31, 2015	Naturally Slim
Program sessions running	August 31 - November 11, 2015	Naturally Slim
Tracking of participant compliance and participation	September 7- November 11, 2015	ACAP
Program "graduation" session (week 10 class starts)	Week 10 of Class; November 2, 2015	Naturally Slim
Naturally Slim Alumni Program Welcome Email	Week 13 of Program	Naturally Slim
Reporting		
"Graduation" biometric screenings, if applicable	Week 11 (no later than 90 days following last class for PG)	Client
Program success measurement and metric reporting	One month post program	ACAP
Presentation of survey feedback, testimonials, clinical outcomes	One month post program	ACAP

References

We understand that hearing from companies that have experienced the measurable impact of the Naturally Slim program can be very helpful. Below is a sample list of clients that we would be happy to put you in touch with to discuss their experience in working with ACAP Health:

- Atmos Energy *(utility provider)*
- BAE Systems *(aviation contractor)*
- Baylor Scott & White Healthcare System *(healthcare)*
- Baylor University *(higher education)*
- Blue-Cross Blue Shield of Kansas City *(insurer)*
- Brinker International *(restaurant)*
- Garmin International *(technology)*
- Genesis Health System *(healthcare)*
- Greyhound Lines *(travel)*
- The Hartford Insurance Company *(insurer)*
- Healthcare Service Corporation – BCBS Plans *(insurer)*
- Macy's *(retailer)*
- Dillard's *(retailer)*
- Texas A&M University *(higher education)*
- Mercy Healthcare System *(national healthcare provider)*
- Sabre – Travelocity *(technology)*
- Southwest Airlines *(travel)*

Reporting

Once your employees have completed the Naturally Slim program, you will want to see the results (and you will want to share them). ACAP Health will provide several different types of reporting to give you a full-range of analysis about the success of the program. The reporting will include:

- Program Analysis
 - Self-reported data (e.g. weight loss & participation) – Week 3, 6 & 10
 - Biometric data (e.g. clinical risk factors), if available
- Post-program Graduate Survey results
 - Participant feedback & testimonials
- Longitudinal Analysis
 - Continued weight loss & risk factor reduction, if available

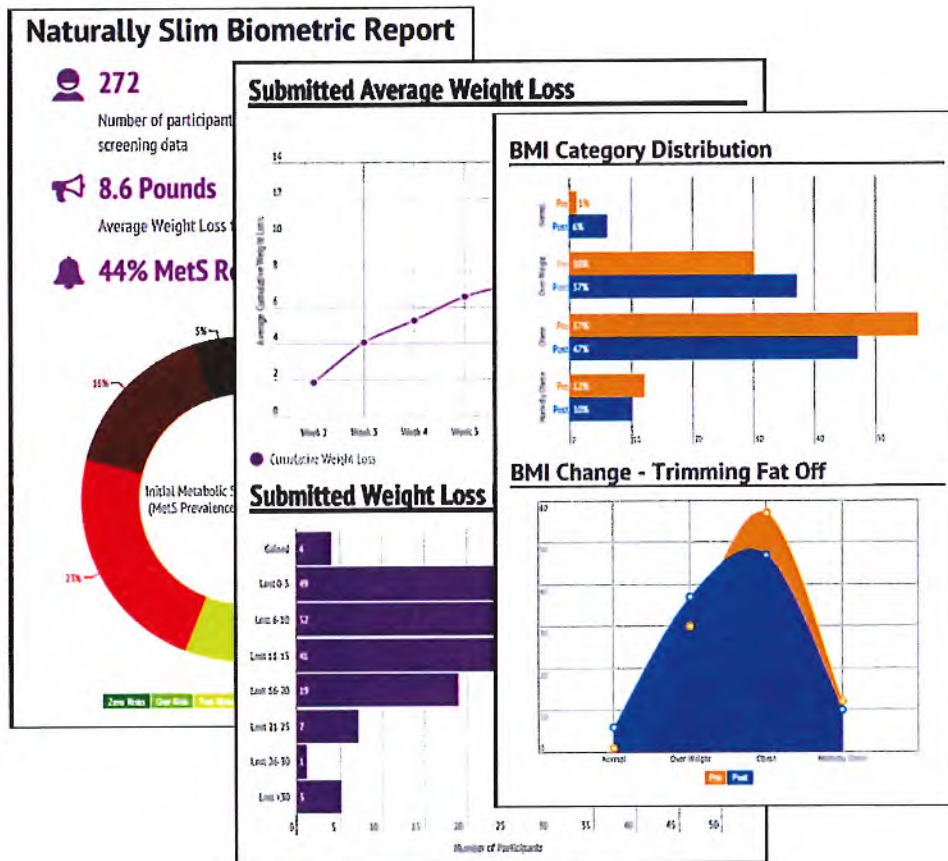

Next Steps

To get started, contact your Wellmark Account Manager to coordinate a consultation with Naturally Slim. The set-up process is simple and your program can begin in as little as six weeks.

For more information about Naturally Slim:

- Visit www.naturallyslim.com/finally
- Contact Nikki Thaden (Sr. Business Development Consultant)
 - nthaden@acaphealth.com
 - Phone: 515-314-3383



Vendor Name/ Contact	Style # 1/Comparable	Style #2/Comparable
<p>Storey Kenworthy Don Holladay Sales Account Executive (712 336-3660 (800) 283-3375 x3460 1612 Jackson Ave. Spirit Lake, Iowa 51360 dholladay@storeykenworthy.com</p>	<p>Sit2Stand-movable</p>	<p>Adjustable Desk Riser</p>
	ERGO Sit2Stand (Single) \$344	<p>Symmetry High Tide II \$308</p>
	ERGO Sit2Stand (Double) \$399	
<p>Perkins Office Supply ONE Source-Perkins Jim Blender Furniture Manager 717 Wesley Parkway Sioux City, Iowa 51101 712-898-1795</p>	ERGO Sit2Stand (Single) \$345	<p>Ergo Topper III \$230</p>
	ERGO Sit2Stand (Double) \$410	<p>Lorrell Adjustable \$295</p>
<p>ERGODIRECT Mirin Riddell (650) 654-4300 (888) 456-3746 1601 Old County Road San Carlos, CA 94070 mirin@ergodirect.com</p>	Ergo Sit2Stand (Single) \$445	Ergo 33-406-085 \$410
	Ergo Sit2Stand (Double) \$561	
<p>VARIDESK Dane Covey- Senior Corp Acct Mgr 972-538-4451 117 Wrangler Dr. Ste 100 Coppell, TX 75019 danecovey@varidesk.com</p>	Not offered	Pro Plus 30-Single \$375
	Not offered	Pro Plus 30-Double \$395
		Cube Corner \$495

Floor mat range between \$35 to \$75



Vendor Name/ Contact	Style # 1/Comparable Sit2Stand-movable	Style #2/Comparable Adjustable Desk Riser
<p>Storey Kenworthy Don Holladay Sales Account Executive (712 336-3660 (800) 283-3375 x3460 1612 Jackson Ave. Spirit Lake, Iowa 51360 dholladay@storeykenworthy.com</p>	<p>ERGO Sit2Stand (Single) \$344 ERGO Sit2Stand (Double) \$399</p>	<p>Symmetry High Tide II \$308</p>
<p>Perkins Office Supply ONE Source-Perkins Jim Blender Furniture Manager 717 Wesley Parkway Sioux City, Iowa 51101 712-898-1795</p>	<p>ERGO Sit2Stand (Single) \$345 ERGO Sit2Stand (Double) \$410</p>	<p>Ergo Topper III \$230</p>
<p>ERGODIRECT Mirin Riddell (650) 654-4300 (888) 456-3746 1601 Old County Road San Carlos, CA 94070 mirin@ergodirect.com</p>	<p>Ergo Sit2Stand (Single) \$445 Ergo Sit2Stand (Double) \$561</p>	<p>Ergo 33-406-085 \$410</p>
<p>VARIDESK Dane Covey- Senior Corp Acct Mgr 972-538-4451 117 Wrangler Dr. Ste 100 Coppell, TX 75019 danecovey@varidesk.com</p>	<p>Not offered Not offered</p>	<p>Pro Plus 30-Single \$375 Pro Plus 30-Double \$395 Cube Corner \$495</p>

Floor mat range between \$35 to \$75

R Richelieu *ERGO*

Sit2Stand Workstation

Convert an existing desk or table into a high-quality and affordable sit to stand workstation and effortlessly go from sitting to standing in seconds. Transform your existing workspace to a healthful environment and immediately benefit from motion and mobility in the work place.



Effortlessly transition from sitting to standing in seconds

Sit2Stand Features

- 18" (45.7 cm) of vertical height adjustment to accommodate the majority of individuals heights.
- Small footprint that can slide effortlessly out of the way to free up desk space.
- 27.5" (69.9 cm) keyboard tray allows space for full size keyboard and mouse.
- Slide in / slide out work surface for additional workspace and storage.
- Convenient rear cable management clips in column and crossbar keep cables organized and out of view.
- Single action quick release adjustment from sitting to standing.
- Locking actuator maintains the unit firmly in position at any height.
- Telescoping upright column promotes a low profile unit in the seated position.
- Durable anodized and powder coated aluminum and steel surfaces (over 95% of components are recyclable).



Slide in / slide out work surface for note-taking, additional storage and desktop organization.



Easy to slide on the desktop, allowing effortless transition between workstation & conventional desk.

TOPPER III SIT-STAND DESKTOP WORKSTATION

- Same vertical line during movement
 - Gas spring offers smooth support
 - Two knobs on each side for easy adjustment and 15 height positions
 - Table top size: 680 x 580mm
 - Keyboard tray size: 325 x 680mm
 - Weight capacity: 15kg.
- 500S2590

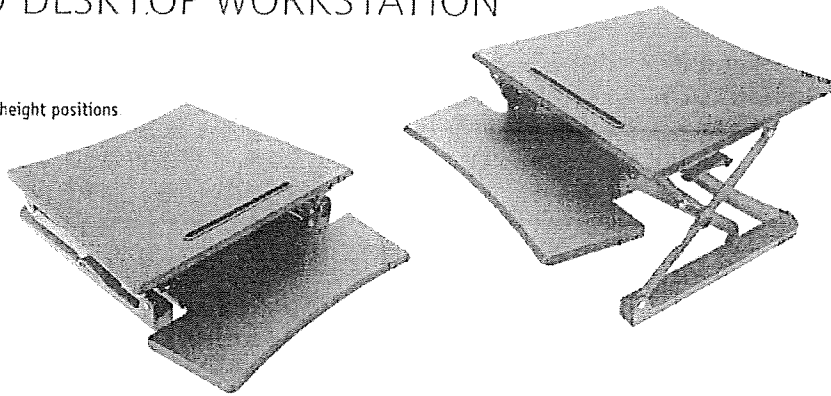

DUET ARM

- Stable, durable design
- Supports large widths and can be customized for work stations
- Slim arms (less than 3/4" each) for better knee clearance
- Height adjustable within 19" range (6 1/2" below work surface)
- Knob for independent tilt positioning
- Sit or stand applications
- Exceeds ANSI/BIFMA standards
- Accommodates secondary work surfaces
- Fixed table height application
- Heavy use typing

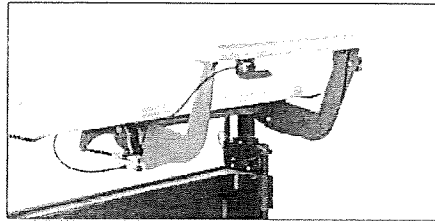

	Short-Swing Arm 6.21 Arms	Full-Long Arm 10.31 Arms
20" width	50070902090	50070802090
23" width	50070902390	50070802390
27" width	50070902790	50070802790
30" width	50070903190	50070803190
30" width	50070903990	50070803990



Office Dealer Dedicated Customer Service Number

www.richelieuergo.com

1-866-440-0448

ergoinfo@richelieu.com

Fax 1-800-890-4139



1-800-361-6000 Canada
1-800-619-5446 United States

Sit2Stand Workstation



Built in cable management

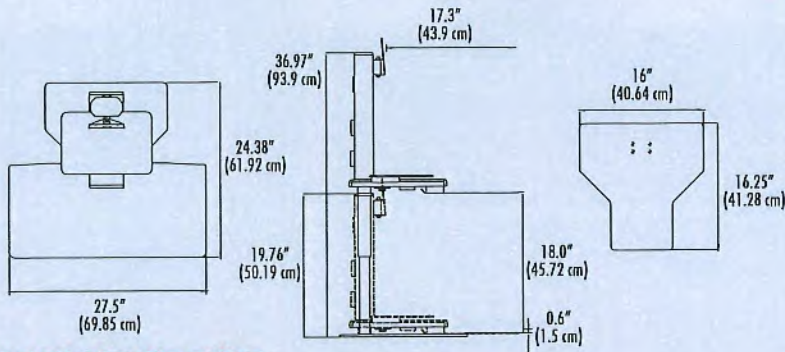

Single Monitor Dimensions

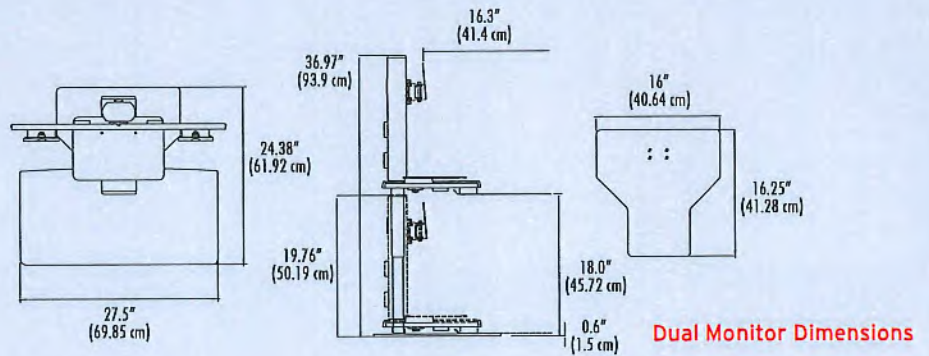

Dual Monitor Dimensions

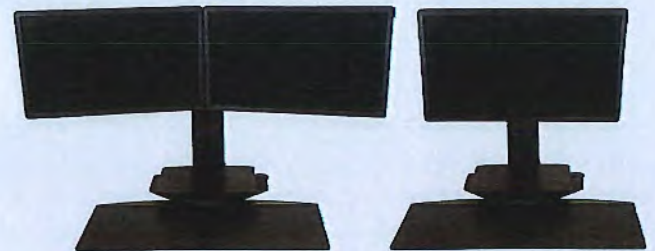

Model	Finish	Monitor Capacity	Monitor Width	Vertical Height Adj.	Mounting
500S2S001R90	Black/Black	Single, 3.5lbs to 11lbs (1.6kg to 5kg)	-	-	VESA
500S2S001R30	Silver/White	Single, 3.5lbs to 11lbs (1.6kg to 5kg)	-	-	VESA
500S2S002R90	Black/Black	Dual, 6.5lbs to 21lbs (3kg to 9.5kg) total	24" Monitor 23.5" actual	18"	75mm & 100mm
500S2S002R30	Silver/White	Dual, 6.5lbs to 21lbs (3kg to 9.5kg) total	24" Monitor 23.5" actual	18"	75mm & 100mm



☎ 1-866-440-0448
ergoinfo@richelieu.com

www.richelieuergo.com

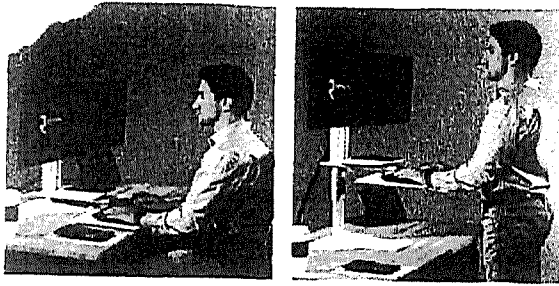

Sit2Stand Workstation goes from sitting to standing in seconds.

Make your workplace work for you.

If better health, freedom of movement, flexibility and improved comfort are your goals, the Richelieu Ergo™ Height-Adjustable Sit2Stand Workstation could be the perfect fit for you. Transform your desk or cubicle instantly into a standing workstation with the touch of a lever.

Fit in fitness without leaving your desk
 Increase productivity, improve focus, fight fatigue and reduce stress from hours of sitting. *No time for the gym?* Even low-level daily exercise has big benefits. Standing three hours a day, five days a week, could be as good for you as running ten marathons a year.

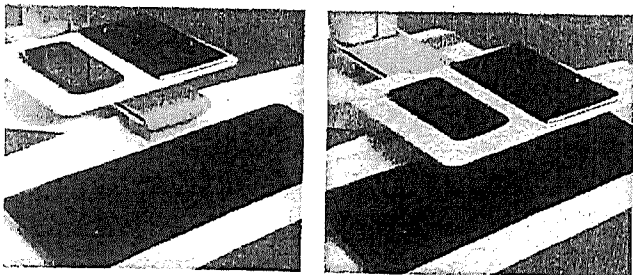

Convenient *slide in, slide out* work surface for phone and office essentials.

Convert an existing desk into a high-quality, affordable Height-Adjustable Sit2Stand Workstation

- ① Industry-leading 18" (45.7cm) vertical height adjustment fits most users.
- ② Small footprint, slides easily out of the way to free up desk space.
- ③ 27.5" (69.9cm) keyboard tray allows space for full size keyboard and mouse.
- ④ Slide-in, slide-out work surface for additional workspace.
- ⑤ On-board cable management keeps area neat and organized.
- ⑥ Single action quick release lever adjusts from sitting to standing in seconds.
- ⑦ Locking lever maintains the unit firmly in position at any height.
- ⑧ Telescoping vertical column ensures a low profile in the seated position.
- ⑨ Durable anodized and powder coated aluminum and steel surfaces (95% recyclable components).
- ⑩ Simple assembly, no special tools required.

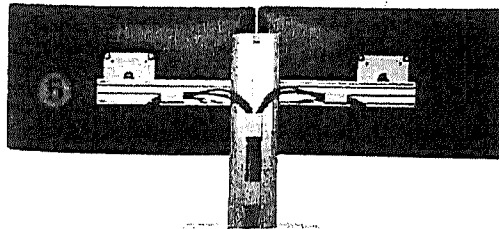
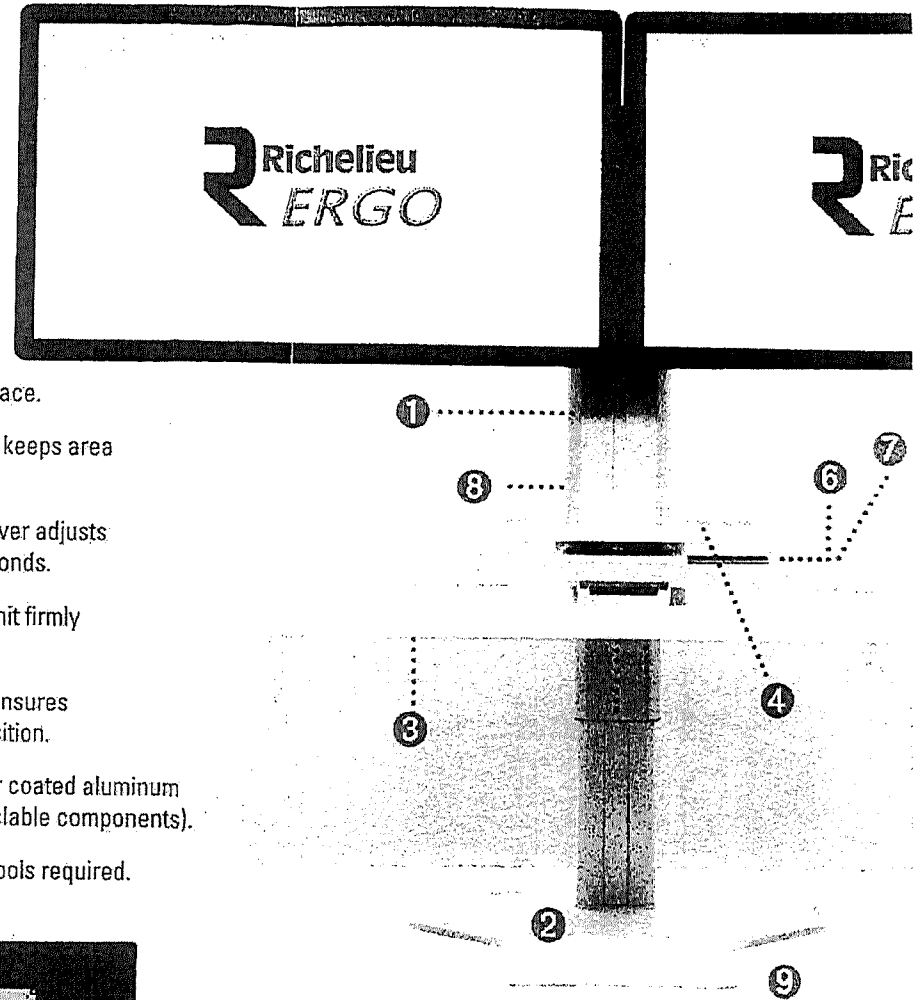

Model	Finish	Monitor Capacity	Monitor Width	Mounting
500S25001R90	Black/Black	Single, 3.5lbs to 11lbs (1.6kg to 5kg)	-	VESA 75mm & 100mm
500S25001R30	Silver/White		-	
500S25002R90	Black/Black	Dual, 6.5lbs to 21lbs (3kg to 9.5kg) total	24" Monitor	
500S25002R30	Silver/White		23.5" actual	

To learn more or to order your workstation, visit RichelieuErgo.com



Woodbury County Historical Committee Meeting

1st Floor Board of Supervisors Meeting Room, 2:30 pm April 4th, 2018

AGENDA

1. Woodbury County Courthouse; Current Project Updates
 - Steam Trap Project
 - Courtroom #207 Window Project
 - Lighting Globe Project
 - Judges Chamber #207 Carpet

2. Woodbury County Budget; LEC Optimization Plan Projects/ CIP Funding Limitation

3. Courthouse Exterior Needs Assessment (Possibly \$2 Million Repairs) / Courthouse Centennial
 - A. Needs-
 - Raise Funds for Repairs
 - Raise Profile of the 2018 Centennial
 - Marketing Campaign
 - High Quality Tours
 - Centennial / needs
 - B. Sources-
 - Courthouse Foundation
 - Gaming Revenue
 - Other

4. Authorizing Budget; Courthouse Foundation 501C3 Funds
 - Recommendation to Board of Supervisors to authorize 501C3 Fund Balance Expenditure

5. 100th Anniversary Celebration
 - Formation of Sub-Committee/ Members
 - Define Event Project Time-Line Mile-Stone Completion Dates
 - Define Event;
 - Define Sub-Committee Member Responsibilities for all categories
 - Number of “open house” event days, Dignitaries List, Invitations, Food, Decorations/ Banners, Advertising, Marketing, Tours, other...

6. Other Information or Concerns



The Children's Museum of Siouxland, Inc.
d/b/a LaunchPAD Children's Museum
623 Pearl Street
Sioux City IA 51101

www.launchpadmuseum.com
712-224-2542
info@launchpadmuseum.com

March 7, 2017

Woodbury County Board of Supervisors
620 Douglas St Room 104
Sioux City, Iowa 51101

Dear Woodbury County Board of Supervisors:

February 11, 2017, marked the 1st anniversary of the opening of LaunchPAD Children's Museum. Your contributions to this endeavor have made the extraordinary happen here at the corner of 7th and Pearl in downtown Sioux City ...

- First and most importantly, LaunchPAD is fulfilling its mission to be Siouxland's champion of educational play and discovery. The interactive exhibits and hands-on classes and camps foster imagination, problem solving and open-ended exploration in the realms of science, technology, engineering, math and the arts.
- In the first year, attendance was 93,717 people. That's 80% higher than the original projections.
- More than 2,500 families have purchased memberships. That's 400% higher than the original first-year goal.
- **The attendance and membership numbers speak volumes about how much a children's museum was needed in the Sioux City area. Your contributions have helped to improve the lives of children as well as the overall quality of life in the region.**
- Hundreds of volunteer hours have helped deliver a positive experience for visitors.
- LaunchPAD is delivering economic development for downtown Sioux City. The two properties to the south of the museum are being re-developed and Pearl Street Park will become a reality later this year.

All of these facts combine to tell a wonderful story about the devotion and pride people like you have for this community and its future. On behalf of the LaunchPAD Board of Directors and staff, **THANK YOU** for everything you've done.

Sincerely,

Bob Fitch, Executive Director
LaunchPAD Children's Museum



"It's a great experience for her to learn while she is playing. I work at night and my wife works in the mornings. We don't do daycare. So LaunchPAD is a great place for Waverly to play with other kids. LaunchPAD has really helped her develop through interaction with other kids."

-Wes Bowman
Dad

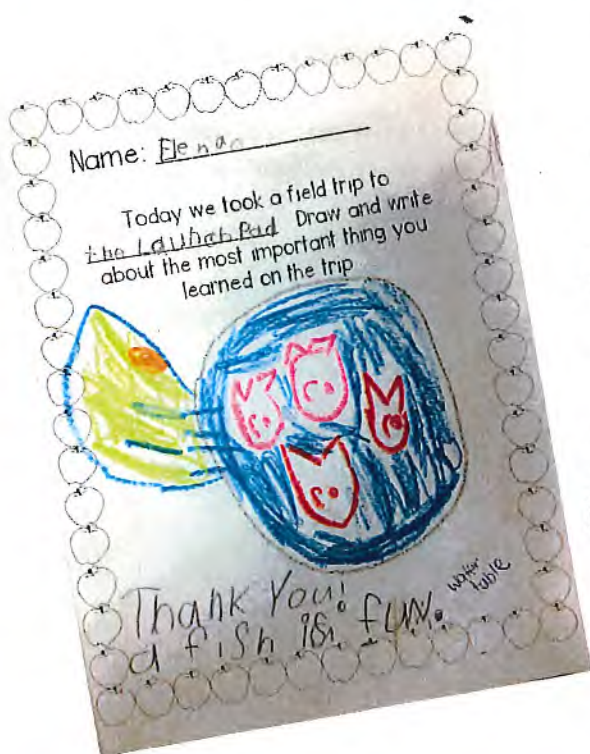
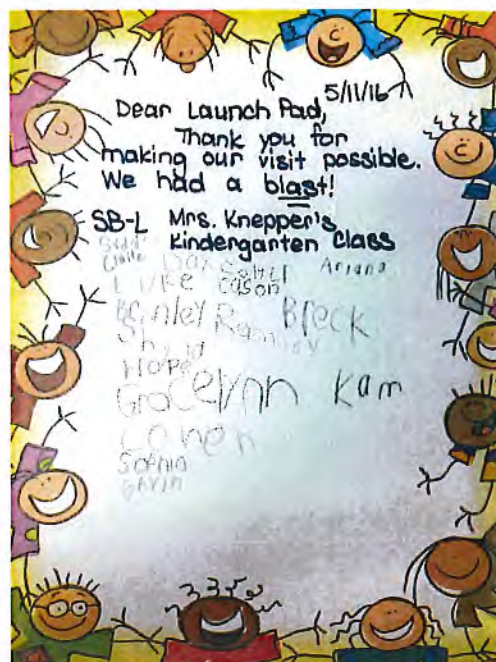

"Tyler and I come to LaunchPAD every Tuesday and Thursday morning. It's a great place that Sioux City really needed. It's so educational. He loves the water and has learned about cooking, baking and even how to catch a ball."

-Marcie Bunkers
Grandma



WOODBURY COUNTY JUVENILE DETENTION CENTER

Trosper-Hoyt Bldg.
822 Douglas St. - 4th Floor
Sioux City, Iowa 51101

Phone 712-279-6622
Email: molsen@sioux-city.org
Fax 712-234-2900

6:00 a.m.

6:00 p.m.

March, 2017

March 6, 2017		11
March 7, 2017	11	11
March 8, 2017	11	11
March 9, 2017	11	11
March 10, 2017	11	11
March 11, 2017	11	11
March 12, 2017	11	11
March 13, 2017	11	

The Center averaged 11 youth per day during the 6 am head count and again at 6 pm. for a weekly average of 11 residents per day.

As of 6 am on March 13, 2017 six out of the eleven clients detained are identified gang members. Of the six, three or fifty percent are identified as highly active and involved in violent crimes.

We are currently detaining two juveniles from the BIA.

Mark Olsen

Director
WCJDC

March 13, 2017



Woodbury County Secondary Roads Department

759 E. Frontage Road • Merville, Iowa 51039
Telephone (712) 279-6484 • (712) 873-3215 • Fax (712) 873-3235

COUNTY ENGINEER

Mark J. Nahra, P.E.
mnahra@woodburycountyiowa.gov

ASSISTANT TO THE COUNTY ENGINEER

Benjamin T. Kusler, E.I.T.
bkusler@woodburycountyiowa.gov

SECRETARY

Tish Brice
tbrice@woodburycountyiowa.gov

To: Board Members
From: Mark Nahra, County Engineer
Date: March 14, 2017
RE: Weekly Work Report

Construction Project Report

As spring approaches, project work will be resuming soon. This was a good winter for doing work on county bridge and structure projects, and some projects are ahead of schedule. For the next couple of weeks, project work will continue as weather conditions allow.

To be let:

BRS-CO97(112)—60-97, D25 Bridge over Whiskey Creek on Old Highway 141 west of Bronson. Letting date: April 18, 2017. The bridge replacement project is a federal aid funded project with 80% federal - 20% farm to market fund dollars paying the cost of construction. The bridge is scheduled to be completed in the 2017 construction season. A new, 30' wide continuous concrete slab structure will replace the existing bridge. This project will result in Old Highway 141 being closed with traffic detoured for much of the summer.

FM-CO97(131)—55-97, HMA resurfacing of County Route L37, Danbury Blacktop, from D38 to Highway 20. Letting Date: April 18, 2017 at the Iowa DOT. This project will do cold in-place recycling of the existing pavement followed by a 2 ½ to 3-inch hot mix asphalt overlay on top of the recycled pavement. This project will be constructed in 2017.

BROS-CO97(129)—55-97, Replacement of Bridge L275 on Union Avenue. Letting Date: April 18, 2017 at the Iowa DOT. The bridge is programmed for replacement with 80% federal aid bridge replacement funds, 20% farm to market funds. This project will be constructed in 2017. County Bridge L275 is on Union Avenue between 190th and 200th Streets. Summer 2016 inspection of the structure has determined that severe deterioration to the piling in the north pier required that the bridge be closed as it is no longer safe to carry traffic. The bridge had been posted 10 tons prior to its closure. The bridge has been closed through the winter of 2016-2017 and will remain so for much of 2017 the new structure is completed.

L-B(W107)—73-97, Replacement of Bridge W107 on 330th Street west of Danbury. Letting date: Late May 2017. This bridge is programmed for replacement during FY 2017 with special project levy funds. County bridge W107 is on 330th Street between Michigan and O'Brien Avenues. The existing bridge is posted 3 tons and subject to monthly inspection due to the condition of the bridge

caps on the abutments. The new bridge will be a 80' x 30' Single Span Precast Concrete Beam Bridge.

Under Contract:

L-C(M208)—73-97, Bridge replacement on Pocahontas Avenue between 270th and 280th Streets. Letting date: January 24, 2017. Late Start Date: April 15, 2017. Contractor: Midwest Contracting. Bid price: \$127,399. The existing bridge has been posted for restricted loads due to deteriorating condition. This is a locally funded project paid from the secondary road fund. A box culvert has been designed to replace the existing bridge and has received Corps of Engineer approval and permitting. The Board has awarded the bid to the low bidder and approved the contract at the March 10, 2017 meeting. No preconstruction meeting has been scheduled for the project yet. The project is scheduled to be completed in the 2017 construction season.

L-B(D38)—73-97, Bridge replacement on 120th Street between Emmett and Fayette Avenues. Letting date: October 11, 2016. Late Start Date: April 15, 2016. Contractor: Dixon Construction. Bid price: \$397,114.00. This is a locally funded project paid from the secondary road fund.

A preconstruction meeting was held with the prime contractor on November 18th. The contractor started work the week of November 21, 2016. Pier pile driving have been driven and encased. Abutment pile are also driven and the bridge berms have been shaped for riprap placement. Abutment concrete pours are the next item of work followed by falsework construction. Work will continue as weather conditions are favorable. The project is scheduled to be completed in the 2017 construction season.

L-B(X14)—73-97, Bridge on 280th Street north of Danbury. Letting date: April 5, 2016. Late Start Date: August 1, 2016. Contractor: Graves Construction. Bid price: \$490,806.48. This is a locally funded project from the \$1.3 million special projects levy paying the cost of construction.

The contractor has moved on site and started work. Pile driving is complete at both abutments and piers, the pier piling are encased and the abutments are poured. Channel and berm shaping and riprap placement are underway. We anticipate that falsework construction is nearing completion. Installation of reinforcing steel is the next work item. Work will continue as weather permits. Project completion is expected before July 2017.

L-B(L212)—73-97, Bridge replacement on Story Avenue between 190th and 200th Streets. Letting date: July 26, 2016. Late Start Date: September 26, 2016. Contractor: Dixon Construction. Bid price: \$238,096.50. The existing bridge is posted to a maximum 20 gross load and is in deteriorating condition. This is a locally funded project paid from the secondary road fund. A box culvert has been designed to replace the existing bridge and has been submitted for Corps of Engineer approval and permitting.

The board approved the contract at the August 16th board meeting. A preconstruction meeting was held with the contractor on November 18th. Work on the project started in December. All concrete work is completed and the box culvert is finished. Backfilling around the culvert, road reconstruction, and final channel shaping remain for project completion. This work cannot begin until frost comes out of the roadway. The project is scheduled to be completed early in 2017.

FM-CO97(126)—55-97, HMA resurfacing of County Route D22, Old Highway 20. Letting date: September 20, 2016. Contractor: Knife River Midwest. Bid price: \$2,060,532.31. The project has been let by the Iowa DOT and we are awaiting bid tabulations and an award recommendation from the Iowa DOT Office of Contracts. The project will overlay the existing pavement on county road D22 from the intersection of K49 northeast of Lawton to approximately one half mile east of Buchanan Avenue. Some cross-road culverts will also be replaced as part of the project work. The project will be paid for with county farm to market funds. Project work will be done in early

2017, with a preconstruction meeting scheduled for next week. Contracts were approved by the Board at their November 8, 2016 meeting.

Work Under Design:

Design work is underway on the following projects for letting sometime during 2017.

250th Street Grading Project - 2.25-mile grade for paving project south of Anthon. Right of way will be necessary to allow construction of this road. Final design is underway. Once design is complete, there will be a preliminary rollout of the design with affected landowners. Platting and right of way acquisition will follow the rollout. We are working toward a summer 2017 letting. This project is funded with special project levy funds.

Bridge Q10 – Design work is underway to replace an aging greenwood structure on 220th street west of Bronson. The existing bridge will be replaced with a large box culvert. A summer 2017 letting is planned. This project is funded with special project levy funds.

280th Street Intersection relocation – Design work is nearing completion on the relocation of the intersection of 280th Street and Old Highway 141. The existing intersection has restricted sight distance to the north and is a hazardous site for farm traffic entering higher speed traffic on Old Highway 141. This project is being done in cooperation with a local landowner who is donating the right of way for the new intersection. A letting is planned for the summer of 2017 with work to be completed before November 2017.

Bridge L1 – This structure is on Old Highway 20 near Cushing. The project involves the replacement of an existing short span bridge with a concrete box culvert. The current bridge is restricted to less than legal loads. This project is scheduled for 2017 construction.

Bridge D156 – This structure is on Franklin Avenue north of Old Highway 20/150th Street. The structure is posted 8 tons. The existing structure is significantly oversized and built from salvaged materials. The replacement structure is proposed to be a large culvert. This project is funded with money received in the local budget from the new \$0.10 state fuel tax. The project is scheduled for 2017 construction.

OTHER PROJECTS:

COUNTY BRIDGE B82

County Bridge B82 is on 140th Street between Kossuth and Lee Avenues. It was one of the flood damaged structures from the June 18, 2016 flood event. Initially, we were going to try to replace the east abutment bridge piling to reopen the bridge this fall, but since it would remain a posted bridge and it is scheduled for replacement in the 2017 construction season, we will be moving it forward in our design schedule to replace it in whole, hopefully with a winter 2016-2017 letting. The result is that the bridge will be closed through the winter of 2016-2017.

ORTON SLOUGH DRAINAGE DISTRICT

Work is starting this week on the Orton Slough Ditch cleanout. This work was let to contract by the Board of Supervisors on behalf of the drainage district. The work is being done by L.A. Carlson Construction. Ditch cleaning and shaping work is complete. Seeding of the disturbed areas remains. The ground is now frozen, so warmer temperatures are needed to allow completion of the project.

HASKELL AVENUE BRIDGE

The Board will be receiving quotes for removal of the existing Haskell Avenue Bridge in late December. The bridge cannot be repaired as it has been shifted off its bearings by over 5 feet at the south end. The remaining substructure acts like a trash rack in the stream and channel damage will be minimized by removing the bridge prior to spring flooding. Removal of the bridge will not preclude replacement of the bridge, if the board decides to replace the bridge.

The Board will need to discuss whether the bridge should be replaced. It is a convenient road for people from Merville that are headed north to LeMars or the north side of Sioux City. The replacement structure will cost approximately \$600,000 and I feel that this money could be better spent replacing another bridge on the county system being that this project only saves approximately ½ mile of out of distance travel. This will be the Board's choice as to whether the bridge is replaced or the road is dead ended north of the McElheny Creek channel. I would like to schedule a discussion of the bridge in April.

220th STREET EAST OF OLD LAKEPORT ROAD

Due to deterioration of a seal coat installed to provide a dust free road on 220th Street in proximity to a large rural subdivision, 220th Street will require extensive work this summer. The seal coat is in poor condition and can no longer be cost effectively patched. A decision will need to be made in consultation with area residents as to the type of improvement and continued maintenance of the roadway. I am hoping once budgeting is done that the Board might find time for a field trip to look at the road prior to a public information meeting with the area landowners so that we can discuss alternatives for maintaining an acceptable road for area residents. Many of the rural lots are subject to paving agreements put in place prior to the current landowners acquiring the property. Many other lots are subject to no such agreement. Assessing the cost of road improvement is difficult to address fairly considering the varied land use fronting the road and the lack of paving agreements covering significant areas of the properties fronting the road.