



**NOTICE OF MEETING OF THE WOODBURY COUNTY BOARD OF SUPERVISORS
(MAY 12, 2026) (WEEK 20 OF 2026)**

Live streaming at:

<https://www.youtube.com/user/woodburycountyiowa>

Agenda and Minutes available at:

www.woodburycountyiowa.gov

Daniel A. Bittinger II
389-4405

dbittinger@woodburycountyiowa.gov

Kent T. Carper
570-7681

kcarper@woodburycountyiowa.gov

David L. Dietrich
870-9224

ddietrich@woodburycountyiowa.gov

Mark E. Nelson
540-1259

mnelson@woodburycountyiowa.gov

Matthew A. Ung
490-7852

matthewung@woodburycountyiowa.gov

You are hereby notified a meeting of the Woodbury County Board of Supervisors will be held May 12, 2026, at **4:30 p.m.** in the Basement of the Courthouse, 620 Douglas Street, Sioux City, Iowa, for the purpose of taking official action on the agenda items shown hereinafter and for such other business that may properly come before the Board.

This is a formal meeting during which the Board may take official action on various items of business. Members of the public wishing to speak on an item must follow the participation rules adopted by the Board of Supervisors.

1. Please silence cell phones and other devices while in the Boardroom.
2. The Chair will recognize the agenda item presenter before asking for public comments or board discussion.
3. Members of the public will approach the microphone one at a time and give their name and city of residence before their statement.
4. Members of the public who comment will limit their remarks to three minutes on any one item and address their remarks to the Board.
5. At the beginning of discussion on any item, the Chair may request statements in favor of an action be heard first followed by statements in opposition to the action. The Chair may also request delegates provide statements on behalf of multiple speakers.
6. Any concerns or questions which do not relate to a scheduled item on the agenda will be heard under the item "Citizen Concerns." Please note the Board is legally prohibited from taking action on or engaging in deliberation on concerns not listed on the agenda, and in such cases the Chair will request further discussion take place after properly noticed.
7. Public comment by electronic or telephonic means is prohibited except for a particular agenda item when approved by the Chair 24 hours before a meeting or by a majority of the board during a meeting for a subsequent meeting.

AGENDA

4:30 p.m. Call Meeting to Order – Pledge of Allegiance to the Flag – Moment of Silence

1. Approval of the agenda

Action

Consent Agenda

Items 2 through 9 constitute a Consent Agenda of routine action items to be considered by one motion. Items pass unanimously unless a separate vote is requested by a Board Member.

2. Approval of the minutes of May 5, 2026
3. Approval of claims.
4. Board Administration – Karen James
 - a. Approval of lifting tax suspensions for petitioners who failed to re-certify their income or income does not qualify for continued tax suspension
 - b. Approval of resolution for a tax suspension for T.V.
 - c. Approval of resolution for a tax suspension for D.B.

5. Secondary Roads – Laura Sievers
Approve the utility permits for MidAmerican Energy Company
6. County Treasurer – Tina Bertrand
Approval of refund of overpayments by Corelogic on several parcels
7. Planning/Zoning – Daniel Priestley
Approval to re-schedule the dates and times for 3 public hearings on a proposed Zoning Ordinance Map Amendment (rezone) of 16.96 acres located on Parcel #874727200011, Section 27, T87N R47W (Liberty Township) from Agricultural Preservation (AP) to the Agricultural Estates (AE) Zoning District (Property Address: 2634 Buchanan Ave., Salix, IA 51052) Tuesday, June 9, 2026, 4:40 PM, Tuesday, June 16, 2026, 4:40 PM, Tuesday, June 23, 2026, 4:40 PM
8. County Auditor – Michelle Skaff
 - a. Consideration and approval of liquor license for Woodbury County Fair, Merville, IA
 - b. Consideration and approval of liquor license for Scarecrow Farm, Lawton, IA
 - c. Consideration and approval of liquor license for Oscar Carl Vineyard, Sioux City, IA
 - d. Consideration and approval of liquor license for Correctionville Golf Club, Correctionville, IA
9. Human Resources – Melissa Thomas
 - a. Approval of Memorandum of Personnel Transactions
 - b. Authorization to Initiate Hiring Process

End of Consent Agenda

10. Board Administration - Ryan Ericson
FY27 Capital Improvement Requests
 1. Secondary Roads Information
 2. Auditor Information
 3. Building Services Information
 4. Bldg Svs/Juvenile Detention Information
 5. Conservation Information
 6. Siouxland District Health Information
 7. Emergency Services Information
 8. Sheriff Information
 9. Treasurer Information
 10. WCICC Information
11. Building Services – Kenny Schmitz
Approval of E911 Communications backup site to be located at the Woodbury County Law Enforcement Center Lower Level Action
12. Reports on Committee Meetings Information
13. Citizen Concerns Information
14. Board Concerns Information

ADJOURNMENT

Subject to Additions/Deletions

CALENDAR OF EVENTS

WED., MAY 13	7:30 a.m.	SIMPCO Executive Finance Committee Meeting, 6401 Gordon Dr.
	8:05 a.m.	Woodbury County Information Communication Commission, First Floor Boardroom
	12:00 p.m.	District Board of Health Meeting, 1014 Nebraska St.
	6:30 p.m.	911 Service Board Meeting, Public Safety Center, Climbing Hill
THU., MAY 14	12:00 p.m.	SIMPCO Board of Directors, 6401 Gordon Drive.
	4:00 p.m.	Conservation Board Meeting, Dorothy Pecaut Nature Center, Stone Park
FRI., MAY 15	9:00 a.m.	Hungry Canyons Alliance Meeting, 305 Railroad Ave., Glenwood, IA
	12:00 p.m.	Siouxland Human Investment Partnership Board Meeting, 2540 Glenn Ave.
WED., MAY 20	12:00 p.m.	Siouxland Economic Development Corporation Meeting, 617 Pierce St., Ste. 202
THU., MAY 21	4:30 p.m.	Community Action Agency of Siouxland Board Meeting, 2700 Leech Avenue
FRI., MAY 22	1:00 p.m.	Region IV Hazardous Materials Response Commission, 6401 Gordon
MON., MAY 25	5:00 p.m.	Zoning Commission Meeting, Courthouse Basement Boardroom
THU., MAY 28	10:00 a.m.	Siouxland Regional Transit Systems (SRTS) Board Meeting, 6401 Gordon Dr.
	11:15 a.m.	Western Iowa Community Improvement Regional Housing Trust Fund Board of Directors, 6401 Gordon, Dr.
MON., JUNE 1	5:00 p.m.	Board of Adjustment meeting, Courthouse Basement Boardroom
WED., JUNE 3	7:30 a.m.	SIMPCO Executive/Finance Committee, 6401 Gordon Drive
	10:00 a.m.	Loess Hills Alliance Stewardship Meeting, Pisgah, Iowa
	11:00 a.m.	Loess Hills Alliance Executive Meeting
	1:00 p.m.	Loess Hills Alliance Full Board Meeting
	4:45 p.m.	Veteran Affairs Meeting, Veteran Affairs Office, 1211 Tri-View Ave.
WED., JUNE 10	8:05 a.m.	Woodbury County Information Communication Commission, First Floor Boardroom
	12:00 p.m.	District Board of Health Meeting, 1014 Nebraska St.
THU., JUNE 11	4:00 p.m.	Conservation Board Meeting, Dorothy Pecaut Nature Center, Stone Park

Woodbury County is an Equal Opportunity Employer. In compliance with the Americans with Disabilities Act, the County will consider reasonable accommodations for qualified individuals with disabilities and encourages prospective employees and incumbents to discuss potential accommodations with the Employer.

Federal and state laws prohibit employment and/or public accommodation discrimination on the basis of age, color, creed, disability, gender identity, national origin, pregnancy, race, religion, sex, sexual orientation or veteran's status. If you believe you have been discriminated against, please contact the Iowa Civil Rights Commission at 800-457-4416 or Iowa Department of Transportation's civil rights coordinator. If you need accommodations because of a disability to access the Iowa Department of Transportation's services, contact the agency's affirmative action officer at 800-262-0003.

MAY 5, 2026, NINETEENTH MEETING OF THE WOODBURY COUNTY BOARD OF SUPERVISORS

The Board of Supervisors met on Tuesday, May 5, 2026, at 4:30 p.m. Board members present were Carper, Dietrich, Nelson, and Ung; Bittinger II was absent. Staff members present were Karen James, Board Administrative Assistant, Ryan Ericson, Budget and Finance Director, Melissa Thomas, HR Director, Joshua Widman, Assistant County Attorney, and Michelle Skaff, Auditor/Clerk to the Board.

The regular meeting was called to order with the Pledge of Allegiance to the Flag and a Moment of Silence.

1. Motion by Nelson second by Dietrich to approve the May 5, 2026 agenda. Carried 4-0. Copy filed.

Motion by Nelson second by Dietrich to approve the following items by consent:

2. To approve minutes of the April 28, 2026 meeting. Copy filed.
3. To approve the claims totaling \$3,555,668.08. Copy filed.
4. To approve the reclassification of Haley Messerschmidt, Assistant County Attorney, County Attorney Dept., effective 03-02-2026, \$132,379.00/year, 7%=\$8,390.00/hr. Per AFSCME Attorney-Move from Step 9 to Step 10. Anniversary Date: 3/15/26.; the appointment of Kurtus Palsma, Summer Engineering Aide-Temp, Secondary Roads Dept., effective 04-29-2026, \$20.00/hour. Job Vacancy Posted on 02/25/26. Temp-Not to Exceed 120 Days.; the appointment of Collin Dunnington, Summer Laborer-Temp, Secondary Roads Dept., effective 05-06-2026, \$17.50/hour. Job Vacancy Posted on 2/25/26. Temp-Not to Exceed 120 Days.; the appointment of Debra Clay, Election Clerk-On Call, County Auditor Dept., effective 05-06-2026, \$19.82/hour. Job Vacancy Posted on 4/20/26. Entry Level Salary: \$19.82/hr.; the appointment of Rebecca Stratmeier, Election Clerk-On Call, County Auditor Dept., effective 05-06-206, \$19.82/hour. Job Vacancy Posted on 4/20/26. Entry Level Salary: \$19.82/hr.; the appointment of Nolan Pauley, Civilian Jailer-FT Temp, County Sheriff Dept., effective 05-11-2026, \$26.04/hour. Job Vacancy Posted on 2/18/26. Entry Level Salary: \$26.04/hr.; the appointment of David Rios, Civilian Jailer, County Sheriff Dept., effective 05-11-2026, \$26.04/hour. Job Vacancy Posted on 2/25/26. Entry Level Salary: \$26.04/hr.; the appointment of Dawson Hauptmann, Civilian Jailer, County Sheriff Dept., effective 05-11-2026. \$26.04/hour. Job Vacancy Posted on 3/18/26. Entry Level Salary: \$26.04/hr.; the reclassification of Madison Hattermann, Civilian Jailer, County Sheriff Dept., effective 05-11-2026, \$26.98/hour, 4%=\$0.94/hr. Per CWA Civilian-Move to 3rd Class to 2nd Class. Anniversary Date: 5/15/26.; the reclassification of Taryn Lockhorst, Civilian Jailer, County Sheriff Dept., effective 05-11-2026, \$26.98/hour, 43%=\$0.94/hr. Per CWA Civilian-Move from 3rd Class to 2nd Class. Anniversary Date: 5/15/26.; the reclassification of Maria Francisco Pablo, Civilian Jailer, County Sheriff Dept., effective 05-11-2026, \$26.98/hour, 4%=\$0.94/hr. Per CWA Civilian-Move from 3rd Class to 2nd Class. Anniversary Date: 5/15/26.; the reclassification of Jacob Gilreath, Civil Engineering Intern, Secondary Roads Dept., effective 05-11-2026, \$3,570.33/bi-weekly, 3%=\$103.99/bi-weekly. Rate Increase Per Wage Matrix – Anniversary Date: 5/18/26.; and the reclassification of Jisleny Ventura Perez, Youth Worker, Juvenile Detention Dept., effective 05-11-2026, \$23.62/hour, 4%=\$0.91/hr. Per AFSCME Juvenile-Move from Step 1 to Step 2. Anniversary Date: 5/21/26. Copy filed.

Carried 4-0.

4. Motion by Nelson second by Dietrich to approve the other of Melissa Thomas, Director, Human Resources Dept., effective 05-01-2026, \$118,386.72/year, 9%=\$10,000/yr. Salary Increase; the appointment of Vicki Ackerman, Election Clerk-On Call, County Auditor Dept., effective 05-13-2026, \$19.82/hour. Job Vacancy Posted on 4/20/26. Entry Level Salary: \$19.82/hr.; and the appointment of Pamela Bonstead, Election Clerk-On Call, County Auditor Dept., effective 05-13-2026. Carried 4-0. Copy filed.
5. Motion by Nelson second by Carper to approve and authorize the Chairperson to sign a Resolution Regional Hazard Mitigation Plan for FEMA. Carried 4-0.

**RESOLUTION OF THE BOARD OF SUPERVISORS
OF WOODBURY COUNTY, IOWA
RESOLUTION #14,031**

WHEREAS, the 2026 Regional Hazard Mitigation Plan (for Plymouth, Cherokee, Ida, Monona, and Woodbury Counties in Iowa) has been prepared in accordance with FEMA requirements at 44C.F.R.201.6; and,

WHEREAS, the County of Woodbury County, participated in the preparation of a regional plan, the 2026 Regional Hazard Mitigation Plan; and,

WHEREAS, Woodbury County is a governing unit that has afforded its residents an opportunity to comment on and provide input in the Plan and the actions in the Plan; and,

WHEREAS, Woodbury County has reviewed the Plan and affirms that the Plan will be updated no less than every five years.

NOW THEREFORE, BE IT RESOLVED by the County of Woodbury County that Woodbury County Board of Supervisors adopts the 2026 Regional Hazard Mitigation Plan and resolves to execute the actions in the Plan.

ADOPTED this 5th, day of May 2026
WOODBURY COUNTY BOARD OF SUPERVISORS
Copy filed.

- 6. Motion by Dietrich second by Nelson to receive for signatures a Resolution Temporary Road Embargo 220th Street. Carried 4-0.

WOODBURY COUNTY, IOWA
TEMPORARY ROAD EMBARGO – 220TH STREET
RESOLUTION #14,032

WHEREAS, the Woodbury County Board of Supervisors believe certain secondary roads in Woodbury County, Iowa which are paved or unpaved, will be seriously damaged or destroyed unless the use of vehicles thereon is prohibited or permissible weight thereon reduced, and

WHEREAS, Chapter 321, Section 471 of the Code of Iowa, gives said Board the power to prohibit the operations of said vehicles on such roads, and to impose restrictions as to the weight of vehicles on said roads.

NOW THEREFORE BE IT RESOLVED by the Woodbury County Board of Supervisors, that, where signs are erected on a highway, operations of vehicles weighing in excess of said weight limit are prohibited on said highway.

BE IT RESOLVED, that the said secondary roads subject to this resolution are more particularly described as:

- 1. 220th Street - County Route K29 east one and one half miles to the end of the seal coat.
- 2. The County Engineer is instructed to remove said embargo if road conditions allow.

SO RESOLVED this 5th day of May, 2026.
WOODBURY COUNTY BOARD OF SUPERVISORS
Copy filed

- 7. Reports on committee meetings were heard.
- 8. Budget Director Ryan Ericson shared that CIP requests will be heard next week.
- 14. Board concerns were heard.

The Board adjourned the regular meeting until May 12, 2026.

Meeting sign in sheet. Copy filed.

WOODBURY COUNTY AGENDA ITEM(S) REQUEST FORM

Date: 5/6/2026 Weekly Agenda Date: 5/12/2026

Elected Official / Department Head / Citizen: Karen James - Administrative Assistant

Wording for Agenda Item:

Approval of lifting tax suspensions for petitioners who failed to re-certify their income or income does not qualify for continued tax suspension

Action Required:

Approve Ordinance

Approve Resolution

Approve Motion

Hold Public Hearing

Informational

Attachments

Set Time:

Reviewed by County Attorney's Office:

Background & Financial Impact:

Annually, the Board of Supervisors requires those receiving tax suspensions to re-certify their income. Those petitioners who fail to re-certify their income by the deadline or if their income does not qualify for continued tax suspension, will be turned over to the Board of Supervisors for action on lifting the tax suspension.

Recommendation:

Attachments:

[Attachment 1](#)

[Approved by Board of Supervisors on March 17, 2026](#)

WOODBURY COUNTY AGENDA ITEM(S) REQUEST FORM

Date: 5/6/2026 Weekly Agenda Date: 5/12/2026

Elected Official / Department Head / Citizen: Karen James - Administrative Assistant

Wording for Agenda Item:

Approval of resolution for a tax suspension for T.V.

Action Required:

Approve Ordinance

Approve Resolution

Approve Motion

Hold Public Hearing

Informational

Attachments

Set Time:

Reviewed by County Attorney's Office:

Background & Financial Impact:

Please consider this request for a tax suspension for T.V. If the Board approves this request, the suspension resolution requires the chairman's signature.

Recommendation:

Attachments:

[Attachment 1](#)

Approved by Board of Supervisors on March 17, 2026

WOODBURY COUNTY AGENDA ITEM(S) REQUEST FORM

Date: 5/6/2026 Weekly Agenda Date: 5/12/2026

Elected Official / Department Head / Citizen: Karen James - Administrative Assistant

Wording for Agenda Item:

Approval of resolution for a tax suspension for D.B.

Action Required:

Approve Ordinance

Approve Resolution

Approve Motion

Hold Public Hearing

Informational

Attachments

Set Time:

Reviewed by County Attorney's Office:

Background & Financial Impact:

Please consider this request for a tax suspension for D.B. If the Board approves this request, the suspension resolution requires the chairman's signature.

Recommendation:

Attachments:

[Attachment 1](#)

Approved by Board of Supervisors on March 17, 2026

WOODBURY COUNTY AGENDA ITEM(S) REQUEST FORM

Date: 5/7/2026 Weekly Agenda Date: 5/12/2026

Elected Official / Department Head / Citizen: Laura Sievers, PE

Wording for Agenda Item:

Motion to approve the utility permits for MidAmerican Energy Company

Action Required:

Approve Ordinance

Approve Resolution

Approve Motion

Hold Public Hearing

Informational

Attachments

Set Time:

Reviewed by County Attorney's Office:

Background & Financial Impact:

Work in county ROW requires a permit approved by the Board of Supervisors per section 318.8 of the Code of Iowa. The county engineer has reviewed the location and recommends that the work be allowed. No financial impact to the county.

Recommendation:

Motion to approve the utility permits for MidAmerican Energy Company

Attachments:

[MidAmerican Energy Company Permit 160th](#)

[MidAmerican Energy Company Permit Correctionville Rd](#)

Approved by Board of Supervisors on March 17, 2026

PERMIT FOR USE OF COUNTY ROAD/HIGHWAY RIGHT-OF-WAY FOR OVERHEAD AND/OR BURIED UTILITIES ACCOMMODATION

REQUEST BY APPLICANT:

Name MidAmerican Energy Company

Highway Hwy 140, 160th St, Hwy 31

Address 4124 NW Urbandale Dr, Urbandale, IA 50322

Township 89N-44W, 88N-45W, 88N-44W, 88N-43W

City of _____

Office Phone 515-281-2540

Local Phone _____

Section: 1/4 of 1/4 Sec

Type of Utility Installation 1.25" HDPE continous conduit w/96ct fiber optic

T N, R, W
89N-44W, 88N-45W, 88N-44W, 88N-43W

Plans Prepared By Civil Design Advantage

Copy Enclosed x Yes _____ No

Map Showing Location Enclosed x Yes _____ No

Utility Location is _____ cross right-of-way _____ parallel to right-of-way
_____ overhead x _____ underground

Proposed Method of Installation

_____ tunnel _____ suspend on poles _____ cased
x jack & bore _____ suspend on towers _____ trench
_____ open cut _____ x _____ plow

Estimated Starting Date Spring-2026

Estimated Restoration Date Spring-2026

The Applicant understands and agrees that the permitted work shall comply with all permit provisions and conditions listed on the reverse side hereof, and special provisions listed below or attached hereto, and any and all plans, details, or notes attached hereto and made a part thereof. Applicant is to complete in triplicate and send all copies including plans and maps to Woodbury County Engineer, 759 E. Frontage Road, Merville, IA 51039. One executed copy will be returned to the Applicant.

By Matthew Towey
Digitally signed by Matthew Towey
DN: C=US,
E=matthew.towey@midamerican.com,
CN=Matthew Towey
Date: 2026.03.19 11:24:28 -0500
(Signature of Authorized Utility Representative)

Title Program Manager Telecom Transport
Date 4/17/26

PERMIT APPROVAL BY PERMITTING AUTHORITY

The forgoing application is hereby approved and permit issued by the Permitting Authority subject to full compliance by the Applicant with all provisions and conditions stated herein and on the reverse side hereof and all attachments hereto.

By _____
(Signature of Woodbury County Board Chairman)

Title _____

Date _____

By _____
(Signature of Woodbury County Engineer)

Title _____

Date _____

Other Special Provisions:

Permit Provisions and Conditions of Issuance

- 1. The County and/or the County Board of Supervisors will not be charged with any responsibility for damages to the Applicant's property occasioned by any construction or maintenance operations on said county roads, including new or additional right-of-way acquired in connection therewith, subsequent to the building of the Applicant's facilities. The Board will endeavor to give the Applicant sufficient notice of any proposed construction or maintenance work, on either existing or newly acquired right-of-way that is likely to expose, cover up, or disturb any facilities belonging to the Applicant, in order that the Applicant may arrange to protect the facilities. The Board will inform contractors, and others working on the job of the location of the facilities so that reasonable care may be taken to avoid damaging the facilities, however the County and the Board of Supervisors will assume no responsibility for failure to give such notice.

2. The Applicant shall take all reasonable precaution during the construction of said facilities to protect and safeguard the lives and property of the adjacent property owners and the traveling public and shall save the County and the Board of Supervisors harmless of any damages or losses that may be sustained by adjacent property owners and the traveling public on account of such construction operations.
3. Operations in the construction and maintenance of said facilities shall be carried on in such a way as to not interfere with, or interrupt traffic on said roads. However, should the performance of work called for in this permit in any way interfere with or obstruct traffic on said roads, the Applicant shall provide the necessary flagmen as required by the Statutes when one-way traffic is involved and/or otherwise mark said work so as to protect the traveling public.
4. The Applicant shall hold the County and the Board of Supervisors harmless from any damages that may result to said highway because of the construction or maintenance of said facilities and shall reimburse the County or the Board of Supervisors for any expenditures that the County or the Board of Supervisors may have to make on said roads on account of replacement of surfacing gravel and bridge and culvert repairs.
5. Applicant shall lay, construct, operate and maintain said facilities so as not to interfere with natural drainage of the road and so as not to interfere with the construction or maintenance of said roads. When buried cable or wire lines are to be placed lengthwise with the roadway, they shall be placed in the County road shoulder or ditch near the toe of the fore-slope and parallel to centerline of roadbed at a depth of three (3) to four (4) feet by using specially designed plows or by trenching, whichever is appropriate. Plow slots and trenches shall be repacked as necessary to restore the disturbed area to its original condition. For buried line crossings of roadways not paved, an open trench may be dug and the lines placed therein, and the trench back-filled over the lines. Buried line crossings on paved roadways, lines may be placed through the sub-grade by jacking, or by boring a hole just large enough to take the lines; or if the County Engineer approves, a tunnel may be dug through and the cable or wire lines placed therein. All backfill of tunnels and trenches shall be thoroughly compacted in layers of 6" or less in depth. Back-filling of trenches within the right-of-way by not under the traveled roadway shall be tamped sufficiently to avoid settlement. When crossing an existing roadway, all buried facilities shall be placed a minimum of three (3) to four (4) below the bottom of the existing adjacent ditches. Overhead lines, where practical, shall be placed adjacent to and with two (2) feet of the Road/Highway Right-of-Way Line.
6. The Applicant will at any time subsequent to placing the facilities, and at the Applicant's expense, relay, replace, alter, change, reconstruct, or relocate its overhead and/or buried facilities and appurtenances thereto as may become necessary to conform to new grades, alignment, or widening right-of-way, resulting from maintenance or construction operations by the County Board of Supervisors irrespective of whether or not additional right-of-way is acquired in connection with such road improvements. The Applicant agrees to do this within ninety (90) days written notice from the Board of Supervisors, and without cost to the County. If the Applicant is unable to comply within said ninety (90) days, the Board of Supervisors may cause the work to be done and the Applicant will pay the cost thereof upon receipt of statement.
7. All work shall be done in a workmanlike manner; the surrounding ground, slopes, and ditch bottoms shall be reshaped to conform to the area and left in a neat condition satisfactory to the County Engineer. All areas where sod has been damaged or destroyed shall be re-seeded.
8. The Applicant shall notify the County Board of Supervisors at least forty-eight (48) hours in advance of the Applicant's intention of starting work covered by this permit on the road right-of-way. Said notice shall be in writing to the County Engineer.
9. Applicant, its' successors, grantees and assigns shall and hereby agrees to assume all responsibility, risks and liabilities for all accidents and damages that may occur to persons and/or property on account of the work done under this permit, and to this end, indemnify and hold the County and all authorized representatives thereof harmless from any and all claims, damages, losses, and expense including judgements, costs and including attorney's fees, for personal injuries (including death) or property damage arising or resulting from the activities of the Applicant in connection herewith, now and at all times in the future.
10. It is understood that this permit is issued only insofar as Woodbury County has jurisdiction and does not presume to release the Applicant from fulfilling any existing statutes relating to the installation, construction and operation of said facilities.
11. It is further understood that the facilities covered by this permit shall be constructed or installed within one (1) year after the date of approval of this permit, unless otherwise extended in writing by Woodbury County.
12. Engagement in the operations as herein applied for by the Applicant shall be considered and constitute an acceptance of all the terms and conditions herein set forth.

**PERMIT FOR USE OF COUNTY ROAD/HIGHWAY RIGHT-OF-WAY
FOR OVERHEAD AND/OR BURIED UTILITIES ACCOMMODATION**

REQUEST BY APPLICANT:

Name MidAmerican Energy Company

Highway 170th St; Charles Ave; Correctionville Rd
Dallas Ave & 140th Street

Address 4124 NW Urbandale Dr, Urbandale, IA 50322

Township 88N-47W; 88N-46W & 89N-46W
City of _____

Office Phone 515-281-2540 Local Phone _____

Section: 1/4 of 1/4 Sec

Type of Utility Installation 1.25" HDPE continous conduit w/96ct fiber optic

T 88 & 89 R W 47W & 46W

Plans Prepared By Civil Design Advantage

Copy Enclosed x Yes _____ No _____

Map Showing Location Enclosed x Yes _____ No _____

Utility Location is _____ cross right-of-way _____ parallel to right-of-way
_____ overhead x _____ underground

Proposed Method of Installation

_____ tunnel _____ suspend on poles _____ cased
x _____ jack & bore _____ suspend on towers _____ trench
_____ open cut _____ x _____ plow

Estimated Starting Date Spring-2026 Estimated Restoration Date Spring-2026

The Applicant understands and agrees that the permitted work shall comply with all permit provisions and conditions listed on the reverse side hereof, and special provisions listed below or attached hereto, and any and all plans, details, or notes attached hereto and made a part thereof. Applicant is to complete in triplicate and send all copies including plans and maps to Woodbury County Engineer, 759 E. Frontage Road, Merville, IA 51039. One executed copy will be returned to the Applicant.

By Matthew Towey
Digitally signed by Matthew Towey
DN: C=US,
E=matthew.towey@midamerican.com,
CN=Matthew Towey
Date: 2026.03.19 11:24:28 -0500
(Signature of Authorized Utility Representative)

Title Program Manager Telecom Transport
Date 4/1/26

PERMIT APPROVAL BY PERMITTING AUTHORITY

The forgoing application is hereby approved and permit issued by the Permitting Authority subject to full compliance by the Applicant with all provisions and conditions stated herein and on the reverse side hereof and all attachments hereto.

By _____
(Signature of Woodbury County Board Chairman)

Title _____
Date _____

By _____
(Signature of Woodbury County Engineer)

Title _____
Date _____

Other Special Provisions:

Permit Provisions and Conditions of Issuance

- 1. The County and/or the County Board of Supervisors will not be charged with any responsibility for damages to the Applicant's property occasioned by any construction or maintenance operations on said county roads, including new or additional right-of-way acquired in connection therewith, subsequent to the building of the Applicant's facilities. The Board will endeavor to give the Applicant sufficient notice of any proposed construction or maintenance work, on either existing or newly acquired right-of-way that is likely to expose, cover up, or disturb any facilities belonging to the Applicant, in order that the Applicant may arrange to protect the facilities. The Board will inform contractors, and others working on the job of the location of the facilities so that reasonable care may be taken to avoid damaging the facilities, however the County and the Board of Supervisors will assume no responsibility for failure to give such notice.

2. The Applicant shall take all reasonable precaution during the construction of said facilities to protect and safeguard the lives and property of the adjacent property owners and the traveling public and shall save the County and the Board of Supervisors harmless of any damages or losses that may be sustained by adjacent property owners and the traveling public on account of such construction operations.
3. Operations in the construction and maintenance of said facilities shall be carried on in such a way as to not interfere with, or interrupt traffic on said roads. However, should the performance of work called for in this permit in any way interfere with or obstruct traffic on said roads, the Applicant shall provide the necessary flagmen as required by the Statutes when one-way traffic is involved and/or otherwise mark said work so as to protect the traveling public.
4. The Applicant shall hold the County and the Board of Supervisors harmless from any damages that may result to said highway because of the construction or maintenance of said facilities and shall reimburse the County or the Board of Supervisors for any expenditures that the County or the Board of Supervisors may have to make on said roads on account of replacement of surfacing gravel and bridge and culvert repairs.
5. Applicant shall lay, construct, operate and maintain said facilities so as not to interfere with natural drainage of the road and so as not to interfere with the construction or maintenance of said roads. When buried cable or wire lines are to be placed lengthwise with the roadway, they shall be placed in the County road shoulder or ditch near the toe of the fore-slope and parallel to centerline of roadbed at a depth of three (3) to four (4) feet by using specially designed plows or by trenching, whichever is appropriate. Plow slots and trenches shall be repacked as necessary to restore the disturbed area to its original condition. For buried line crossings of roadways not paved, an open trench may be dug and the lines placed therein, and the trench back-filled over the lines. Buried line crossings on paved roadways, lines may be placed through the sub-grade by jacking, or by boring a hole just large enough to take the lines; or if the County Engineer approves, a tunnel may be dug through and the cable or wire lines placed therein. All backfill of tunnels and trenches shall be thoroughly compacted in layers of 6" or less in depth. Back-filling of trenches within the right-of-way by not under the traveled roadway shall be tamped sufficiently to avoid settlement. When crossing an existing roadway, all buried facilities shall be placed a minimum of three (3) to four (4) below the bottom of the existing adjacent ditches. Overhead lines, where practical, shall be placed adjacent to and with two (2) feet of the Road/Highway Right-of-Way Line.
6. The Applicant will at any time subsequent to placing the facilities, and at the Applicant's expense, relay, replace, alter, change, reconstruct, or relocate its overhead and/or buried facilities and appurtenances thereto as may become necessary to conform to new grades, alignment, or widening right-of-way, resulting from maintenance or construction operations by the County Board of Supervisors irrespective of whether or not additional right-of-way is acquired in connection with such road improvements. The Applicant agrees to do this within ninety (90) days written notice from the Board of Supervisors, and without cost to the County. If the Applicant is unable to comply within said ninety (90) days, the Board of Supervisors may cause the work to be done and the Applicant will pay the cost thereof upon receipt of statement.
7. All work shall be done in a workmanlike manner; the surrounding ground, slopes, and ditch bottoms shall be reshaped to conform to the area and left in a neat condition satisfactory to the County Engineer. All areas where sod has been damaged or destroyed shall be re-seeded.
8. The Applicant shall notify the County Board of Supervisors at least forty-eight (48) hours in advance of the Applicant's intention of starting work covered by this permit on the road right-of-way. Said notice shall be in writing to the County Engineer.
9. Applicant, its' successors, grantees and assigns shall and hereby agrees to assume all responsibility, risks and liabilities for all accidents and damages that may occur to persons and/or property on account of the work done under this permit, and to this end, indemnify and hold the County and all authorized representatives thereof harmless from any and all claims, damages, losses, and expense including judgements, costs and including attorney's fees, for personal injuries (including death) or property damage arising or resulting from the activities of the Applicant in connection herewith, now and at all times in the future.
10. It is understood that this permit is issued only insofar as Woodbury County has jurisdiction and does not presume to release the Applicant from fulfilling any existing statutes relating to the installation, construction and operation of said facilities.
11. It is further understood that the facilities covered by this permit shall be constructed or installed within one (1) year after the date of approval of this permit, unless otherwise extended in writing by Woodbury County.
12. Engagement in the operations as herein applied for by the Applicant shall be considered and constitute an acceptance of all the terms and conditions herein set forth.

WOODBURY COUNTY AGENDA ITEM(S) REQUEST FORM

Date: 5/6/2026 Weekly Agenda Date: 5/12/2026

Elected Official / Department Head / Citizen: Tina Bertrand

Wording for Agenda Item:

Approval of refunds of overpayments by Corelogic on several parcels.

Action Required:

Approve Ordinance

Approve Resolution

Approve Motion

Hold Public Hearing

Informational

Attachments

Set Time:

Reviewed by County Attorney's Office:

Background & Financial Impact:

Corelogic overpaid on the below parcels. There is no financial impact. 8847 07 252 025 \$2048.00
8947 35 154 003 \$1424.00 8847 06 406 021 \$1485.00 8847 31 179 011 \$3007.00 8645 06 200
006 \$3986.00 8947 21 305 002 \$2330.00 8948 23 152 002 \$2032.00

Recommendation:

Recommend approving the refund on the above parcels.

Attachments:

[Corelogic refunds](#)

Approved by Board of Supervisors on March 17, 2026

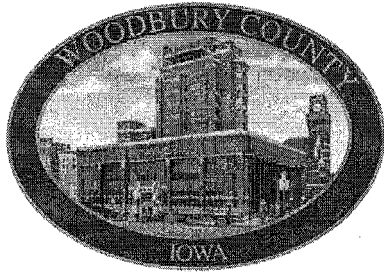

Tina M Bertrand
Treasurer of Woodbury County
Property Tax
822 Douglas Street Suite 102
Sioux City, IA 51101
712-279-6495

May 6, 2026

RE: Refund of overpayments

Dear Board of Supervisors,

The following parcels received overpayments for payment for the March installment. Please authorize refunds to be issued on the following parcels.

8847 07 252 025 (Sonny & Shari Amo) - 4107 Kateri Way Sioux City, Iowa 51106
Overpayment of \$2048.00 paid by Corelogic/Northwest Bank

8947 35 154 003 (Ricardio Camberos) – 514 S Cecelia St Sioux City, Iowa 51106
Overpayment of \$1424.00 paid by Corelogic/Freedom Mortgage

8847 06 406 021 (Cano & Georgina Chico) – 2629 S Mulberry St Sioux City, Iowa 51106
Overpayment of \$1485.00 paid by Corelogic/Shellpoint Mortgage

8847 31 179 011 (Trevor Eyres & Amanda Wilmesherr) – 207 Carriage Ln Sgt Bluff, Iowa 51054
Overpayment of \$3007.00 paid by Corelogic/Pennymac

8645 06 200 006 (Larry Hunt Irrevocable Trust) – 2506 280th St Hornick, Iowa 51026
Overpayment of \$3986.00 paid by Corelogic/PNC Bank

8947 21 305 002 (Alejandro Ochoa & Katrina Trudell) – 107 Stewart Ave Sioux City, Iowa 51104
Overpayment of \$2330.00 paid by Corelogic/Wells Fargo

8948 23 152 002 (Ramiro & Stacey Murillo) – 2020 Hanford St Sioux City, Iowa 51109
Overpayment of \$2032.00 paid by Corelogic/Shellpoint Mortgage

Thank you for your time,

A handwritten signature in black ink that reads "Janet L. Trimpe".

Janet L Trimpe
Woodbury County Treasurer Tax Deputy
jtrimpe@woodburycountyiowa.gov
712-224-6024

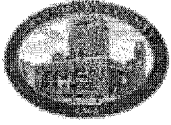

Woodbury County Treasurer
 822 Douglas St. Suite 102
 Sioux City, IA 51101

Receipt Number: R00645638

Cashier Name: Janet Trimpe

Terminal Number: 4

Receipt Date: 3/20/2026 8:08:23 AM

CORELOGIC/NORTHWEST BANK
 4107 KATERI WAY
 SIOUX CITY, IA 51106

Trans Code: 100 - Tax Collections

Account: 884707252025 CORELOGIC/NORTHWEST \$2,048.00

Parcel: 884707252025 Partial Payment

Owner: AMO SONNY D & AMO SHARI A

Prepayment: 2,048.00

Total Balance Due: \$2,048.00

Amount: \$2,048.00

Total Payment Received: \$2,048.00

Change: \$0.00

Payment Method: 7-Internet F Payor: CORELOGIC/NORTHWEST F Reference:

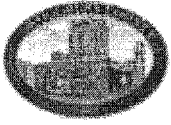

Woodbury County Treasurer
822 Douglas St. Suite 102
Sioux City, IA 51101

Receipt Number: R00645641

Cashier Name: Janet Trimpe

Terminal Number: 4

Receipt Date: 3/20/2026 8:10:12 AM

CORELOGIC/FREEDOM MORTGAGE
514 S CECELIA ST
SIOUX CITY, IA 51106-0315

Trans Code: 100 - Tax Collections

Parcel: 894735154003 Partial Payment

Owner: CAMBEROS RICARDIO ELIAN

Prepayment: 1,424.00

Account: 894735154003 CORELOGIC/FREEDOM MC \$1,424.00

Total Balance Due: \$1,424.00

Amount: \$1,424.00

Total Payment Received: \$1,424.00

Change: \$0.00

Payment Method: 7-Internet f Payor: CORELOGIC/FREEDOM MO Reference:



Woodbury County Treasurer
 822 Douglas St. Suite 102
 Sioux City, IA 51101

Receipt Number: R00645644

Cashier Name: Janet Trimpe

Terminal Number: 4

Receipt Date: 3/20/2026 8:12:02 AM

CORELOGIC/SHELLPOINT MORTGAGE SERVICES
 2629 S MULBERRY ST
 SIOUX CITY, IA 51106

Trans Code: 100 - Tax Collections

Account: 884706406021 CORELOGIC/SHELLPOINT MORTGAGE SERVICES \$1,485.00

Parcel: 884706406021 Partial Payment

Owner: CHICO CANO OSCAR & CHICO GEORGINA

Prepayment: 1,485.00

Total Balance Due: \$1,485.00

Amount: \$1,485.00

Total Payment Received: \$1,485.00

Change: \$0.00

Payment Method: 7-Internet F Payor: CORELOGIC/SHELLPOINT M Reference:

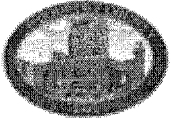

Woodbury County Treasurer
 822 Douglas St. Suite 102
 Sioux City, IA 51101

Receipt Number: R00645646

Cashier Name: Janet Trimpe

Terminal Number: 4

Receipt Date: 3/20/2026 8:13:48 AM

CORELOGIC/PENNYMAC
 207 CARRIAGE LN
 SERGEANT BLUFF, IA 51054

Trans Code: 100 - Tax Collections

Account: 884731179011 CORELOGIC/PENNYMAC

\$3,007.00

Parcel: 884731179011 Partial Payment

Owner: EYRES TREVOR & WILMESHERR AMANDA

Prepayment: 3,007.00

Total Balance Due: \$3,007.00

Payment Method: 7-Internet F Payor: CORELOGIC/PENNYMAC Reference:

Amount: \$3,007.00

Total Payment Received: \$3,007.00

Change: \$0.00



Woodbury County Treasurer
 822 Douglas St. Suite 102
 Sioux City, IA 51101

Receipt Number: R00645651

Cashier Name: Janet Trimpe

Terminal Number: 4

Receipt Date: 3/20/2026 8:17:50 AM

CORELOGIC/PNC BANK
 2506 280TH ST
 HORNICK, IA 51026

Trans Code: 100 - Tax Collections

Parcel: 864506200006 Partial Payment

Owner: HUNT LARRY IRREVOCABLE TRUST

Prepayment: 3,986.00

Account: 864506200006 CORELOGIC/PNC BANK

\$3,986.00

Total Balance Due: \$3,986.00

Amount: \$3,986.00

Total Payment Received: \$3,986.00

Change: \$0.00

Payment Method: 7-Internet F Payor: CORELOGIC/PNC BANK

Reference:



Woodbury County Treasurer
 822 Douglas St. Suite 102
 Sioux City, IA 51101

Receipt Number: R00645653

Cashier Name: Janet Trimpe

Terminal Number: 4

Receipt Date: 3/20/2026 8:20:32 AM

CORELOGIC/WELLS FARGO BANK
 107 STEWART AVE
 SIOUX CITY, IA 51104

Trans Code: 100 - Tax Collections

Account: 894721305002 CORELOGIC/WELLS FARGO

\$2,330.00

Parcel: 894721305002 Partial Payment

Owner: OCHOA ALEJANDRO & TRUDELL KATRINA

Prepayment: 2,330.00

Total Balance Due: \$2,330.00

Amount: \$2,330.00

Total Payment Received: \$2,330.00

Change: \$0.00

Payment Method: 7-Internet F Payor: CORELOGIC/WELLS FARGO Reference:



Woodbury County Treasurer
 822 Douglas St. Suite 102
 Sioux City, IA 51101

Receipt Number: R00645659

Cashier Name: Janet Trimpe

Terminal Number: 4

Receipt Date: 3/20/2026 8:24:06 AM

CORELOGIC/SHELLPOINT MORTGAGE SERVICES
 2020 HANFORD ST
 SIOUX CITY, IA 51109

Trans Code: 100 - Tax Collections

Parcel: 894823152002 Partial Payment

Owner: STEEMKEN CHAD & JOY

Prepayment: 2,032.00

Account: 894823152002 CORELOGIC/SHELLPOINT M

\$2,032.00

Total Balance Due: \$2,032.00

Amount: \$2,032.00

Total Payment Received: \$2,032.00

Change: \$0.00

Payment Method: 7-Internet F Payor: CORELOGIC/SHELLPOINT M Reference:

WOODBURY COUNTY AGENDA ITEM(S) REQUEST FORM

Date: 5/6/2026 Weekly Agenda Date: 5/12/2026

Elected Official / Department Head / Citizen: Daniel J. Priestley

Wording for Agenda Item:

Motion to re-schedule the dates and times for 3 Public Hearings on a proposed Zoning Ordinance Map Amendment (rezone) of 16.96 acres located on Parcel #874727200011, Section 27, T87N R47W (Liberty Township) from Agricultural Preservation (AP) to the Agricultural Estates (AE) Zoning District (Property Address: 2634 Buchanan Ave., Salix, IA 51052) - Tuesday, June 9, 2026, 4:40 PM - Tuesday, June 16, 2026, 4:40 PM - Tuesday, June 23, 2026, 4:40 PM

Action Required:

Approve Ordinance

Approve Resolution

Approve Motion

Hold Public Hearing

Informational

Attachments

Set Time:

Reviewed by County Attorney's Office:

Background & Financial Impact:

William J. Smith has filed a Zoning Ordinance Map Amendment (Rezone) application with Woodbury County to rezone 16.96 acres (Parcel #874727200011, Section 27, T87N R47W, Liberty Township – SW¼ and NW¼ of NE¼) from Agricultural Preservation (AP) to Agricultural Estates (AE). Property Address: 2634 Buchanan Ave., Salix, IA 51052. Mailing Address: 5309 Hwy 75 North, Lot 44, Sioux City, IA 51108 for the purpose of building a single-family dwelling and any accessory structures.

Recommendation:

Re-schedule the dates and times for 3 Public Hearings on a proposed Zoning Ordinance Map Amendment (rezone) of 16.96 acres located on Parcel #874727200011, Section 27, T87N R47W (Liberty Township) from Agricultural Preservation (AP) to the Agricultural Estates (AE) Zoning

District (Property Address: 2634 Buchanan Ave., Salix, IA 51052) - Tuesday, June 9, 2026, 4:40 PM - Tuesday, June 16, 2026, 4:40 PM - Tuesday, June 23, 2026, 4:40 PM

Approved by Board of Supervisors on March 17, 2026

WOODBURY COUNTY AGENDA ITEM(S) REQUEST FORM

Date: 5/4/2026 Weekly Agenda Date: 5/12/2026

Elected Official / Department Head / Citizen: Michelle Skaff

Wording for Agenda Item:

Consideration and approval for liquor license for Woodbury County Fair, Merville, IA.

Action Required:

Approve Ordinance

Approve Resolution

Approve Motion

Hold Public Hearing

Informational

Attachments

Set Time:

Reviewed by County Attorney's Office:

Background & Financial Impact:

N/A

Recommendation:

Approve motion

Attachments:

[Woodbury County Fair](#)

Approved by Board of Supervisors on March 17, 2026

**Office Of The
AUDITOR/RECORDER
Woodbury County**
Michelle K. Skaff, Ph.D.
Auditor/Recorder/
Commissioner of Elections

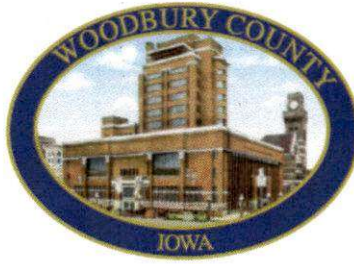

Courthouse – Room 103
620 Douglas
Sioux City, IA 51101
Phone: (712) 279-6702
Fax (712) 279-6629
miskaff@woodburycountyiowa.gov

To: Board of Supervisors

From: Michelle K Skaff, Auditor & Recorder

A handwritten signature in blue ink, appearing to read "M. Skaff", is written over the "From:" line.

Date: May 4, 2026

Subject: Liquor License Application for the Woodbury County Fair, Merville, Iowa.

Please approve and receive for signature, an applicaton for a 8-month, Class C Retail Alcohol, with Outdoor Service privileges, for the Woodbury County Fair, Merville, Iowa. The license would be effective 06/01/2026 through 01/31/2027.

CLASS "C" RETAIL ALCOHOL LICENSE APPLICATION

Business Information

Name of Legal Entity: WOODBURY COUNTY FAIR ASSN INC

FEIN: XX-XXX8215

Business Type: NPO

This business is not registered with the Secretary of State.

Premises Information

Premises DBA: WOODBURY COUNTY FAIR

Premises Address: 206 FAIR ST MOVILLE IA 51039-7518

Premises Type: Fairgrounds

Number of Floors: 1

Control of Premises: Own

Is your premises equipped with at least one adequate, conveniently located indoor or outdoor toilet facility for use by patrons?

Yes

Does your premises conform to all local and state health, fire and building laws and regulations?

Yes

Is your establishment equipped with tables and seats to accommodate a minimum of 25?

Yes

License Information

Effective Date: 01-Jun-2026

Length of License Requested: 8MONTH

Privilege(s) Requested

Outdoor Service - Allows the selling/serving of alcoholic beverages by the license/permit in a designated, adjacent outdoor area.

Provided description of the Outdoor Service Area:

We have a building (Beer Barn), outside gated off garden area located south of the grandstands. We also have a tented (will be structured in near future) area on the north end of the grandstands

Endorsements

Local Authority: Woodbury County

Dramshop Company: IOWA COMMUNITIES ASSURANCE POOL

Ownership Information

Type	Name	ID Type	ID	DOB	Phone	Address	Percentage
Individual	KLASCHEN, REBECCA	SSN	***-**-5262	05-Mar-1973	(712) 873-3707	206 FAIR ST MOVILLE IA 51039-7518	0.00

Criminal History Details

Has anyone listed on the Ownership page been charged or convicted of a felony offense in Iowa or any other state of the United States?
No

Has anyone listed on the Ownership page been convicted of any violation of any state, county, city, federal or foreign law? For traffic violations, only include those that are drug or alcohol related.
No

Criminal Violations

Contact Information

Contact Name: REBECCA KLASCHEN

Phone Number: (712) 873-3707

Email Address: woodburycountyfair@outlook.com

Address: 206 FAIR ST MOVILLE IA 51039-7518

Attestation Information

Attestation Name: REBECCA KLASCHEN

Attestation Date: 14-Apr-2026

WOODBURY COUNTY AGENDA ITEM(S) REQUEST FORM

Date: 5/4/2026 Weekly Agenda Date: 5/12/2026

Elected Official / Department Head / Citizen: Michelle Skaff

Wording for Agenda Item:

Consideration and approval for liquor license for Scarecrow Farm, Lawton, IA.

Action Required:

Approve Ordinance

Approve Resolution

Approve Motion

Hold Public Hearing

Informational

Attachments

Set Time:

Reviewed by County Attorney's Office:

Background & Financial Impact:

N/A

Recommendation:

Approve motion

Attachments:

[Scarecrow Farm](#)

Approved by Board of Supervisors on March 17, 2026

**Office Of The
AUDITOR/RECORDER
Woodbury County**
Michelle K. Skaff, Ph.D.
Auditor/Recorder/
Commissioner of Elections

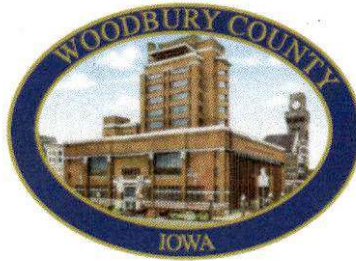

Courthouse – Room 103
620 Douglas
Sioux City, IA 51101
Phone: (712) 279-6702
Fax (712) 279-6629
miskaff@woodburycountyiowa.gov

To: Board of Supervisors

From: Michelle K Skaff, Auditor & Recorder

A handwritten signature in black ink, appearing to read "MKS", is written over the name "Michelle K Skaff" in the "From:" field.

Date: May 4, 2026

Subject: Liquor License Application for the Scarecrow Farm, Lawton, Iowa.

Please approve and receive for signature, an applicaton for a 12-month, Special Class C Retail Liquor License, with Outdoor Service privelages, for the Scarecrow Farm, Lawton, Iowa. The license would be effective 06/01/26 through 05/31/27.

SPECIAL CLASS "C" RETAIL ALCOHOL LICENSE RENEWAL

Business Information

Name of Legal Entity: SCARECROW FARM LLC

FEIN: XX-XXX6866

Business Type: Limited Liability Company

This business is registered with the Secretary of State.

Business Number of Secretary of State: 819087

Premises Information

Premises DBA: SCARECROW FARM

Premises Address: 1592 CHARLES AVE LAWTON IA 51030-8074

Premises Type: Special Event

Number of Floors: 1

Control of Premises: Own

Is your premises equipped with at least one adequate, conveniently located indoor or outdoor toilet facility for use by patrons?
Yes

Does your premises conform to all local and state health, fire and building laws and regulations?
Yes

Is your establishment equipped with tables and seats to accommodate a minimum of 25?
Yes

Has the number of floors of the premises changed?
No

Have there been any changes to the premises in the last 12 months? This includes any changes that affect where alcohol is manufactured, stored, sold or consumed, such as adding, deleting, or changing permanent outdoor service areas.
No

Has there been a change in the control of property over the last 12 months? This includes a renewed/updated lease agreement, or changing from a deed to a lease, or a lease to a deed.
No

License Information

Effective Date: 01-Jun-2026

Length of License Requested: 12MONTH

Privilege(s) Requested

Outdoor Service - Allows the selling/serving of alcoholic beverages by the license/permit in a designated, adjacent outdoor area.

Provided description of the Outdoor Service Area:

Outdoor agritainment venue with multiple concession sales areas.

Endorsements

Local Authority: Woodbury County

Dramshop Company: ILLINOIS CASUALTY CO

Ownership Information

Type	Name	ID Type	ID	DOB	Phone	Address	Percentage
Individual	SHUMANSKY , TODD	SSN	***-**-6383	25-May-1 968			50.00
Individual	SHUMANSKY , TARA	SSN	***-**-1749	26-May-1 977			50.00

Criminal History Details

Has anyone listed on the Ownership page been charged or convicted of a felony offense in Iowa or any other state of the United States?

No

Has anyone listed on the Ownership page been convicted of any violation of any state, county, city, federal or foreign law? For traffic violations, only include those that are drug or alcohol related.

No

Criminal Violations

Contact Information

Contact Name: TODD SHUMANSKY

Phone Number: 7122533463

Email Address: toddshumansky@gmail.com

Address: 1592 CHARLES AVE LAWTON IA 51030-8074

Attestation Information

Attestation Name: TODD SHUMANSKY

Attestation Date: 25-Mar-2026

WOODBURY COUNTY AGENDA ITEM(S) REQUEST FORM

Date: 5/4/2026 Weekly Agenda Date: 5/12/2026

Elected Official / Department Head / Citizen: Michelle Skaff

Wording for Agenda Item:

Consideration and approval for liquor license for Oscar Carl Vineyard, Sioux City, IA.

Action Required:

Approve Ordinance

Approve Resolution

Approve Motion

Hold Public Hearing

Informational

Attachments

Set Time:

Reviewed by County Attorney's Office:

Background & Financial Impact:

N/A

Recommendation:

Approve motion

Attachments:

[Oscar Carl Vineyard](#)

Approved by Board of Supervisors on March 17, 2026

**Office Of The
AUDITOR/RECORDER
Woodbury County**
Michelle K. Skaff, Ph.D.
Auditor/Recorder/
Commissioner of Elections

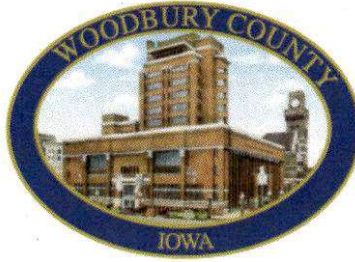

Courthouse – Room 103
620 Douglas
Sioux City, IA 51101
Phone: (712) 279-6702
Fax (712) 279-6629
miskaff@woodburycountyiowa.gov

To: Board of Supervisors

From: Michelle K Skaff, Auditor & Recorder 

Date: May 4, 2026

Subject: Liquor License Application for the Oscar Carl Vineyard, Sioux City, Iowa.

Please approve an applicaton for a 12-month Class C Retail Alcohol permit with privileges of, Outdoor Servie for the Oscar Carl Vineyard, effective 06/02/26 through 06/01/27.

CLASS "C" RETAIL ALCOHOL LICENSE RENEWAL

Business Information

Name of Legal Entity: ROOM FOR MORE ENTERPRISES INC

FEIN: XX-XXX0293

Business Type: Corporation

This business is registered with the Secretary of State.

Business Number of Secretary of State: 375509

Premises Information

Premises DBA: OSCAR CARL VINEYARD

Premises Address: 1473 BUCHANAN AVE SIOUX CITY IA 51106-5467

Premises Type: Vintner

Number of Floors: 3

Control of Premises: Lease

Is your premises equipped with at least one adequate, conveniently located indoor or outdoor toilet facility for use by patrons?

Yes

Does your premises conform to all local and state health, fire and building laws and regulations?

Yes

Is your establishment equipped with tables and seats to accommodate a minimum of 25?

Yes

Has the number of floors of the premises changed?

No

Have there been any changes to the premises in the last 12 months? This includes any changes that affect where alcohol is manufactured, stored, sold or consumed, such as adding, deleting, or changing permanent outdoor service areas.

No

Has there been a change in the control of property over the last 12 months? This includes a renewed/updated lease agreement, or changing from a deed to a lease, or a lease to a deed.

No

License Information

Effective Date: 02-Jun-2026

Length of License Requested: 12MONTH

Privilege(s) Requested

Outdoor Service - Allows the selling/serving of alcoholic beverages by the license/permit in a designated, adjacent outdoor area.

Provided description of the Outdoor Service Area:

Upper and covered patios, vineyard pavilion

Endorsements

Local Authority: Woodbury County

Dramshop Company: FOUNDERS INSURANCE COMPANY

Ownership Information

Type	Name	ID Type	ID	DOB	Phone	Address	Percentage
Individual	OLSEN, MELANIE	SSN	***-**-3203	11-May-1 959		1473 BUCHANAN AVENUE SIOUX CITY IA 51106	50.00
Individual	OLSEN, ROY	SSN	***-**-9132	16-Apr-19 59		1473 BUCHANAN AVENUE SIOUX CITY IA 51106	50.00

Criminal History Details

Has anyone listed on the Ownership page been charged or convicted of a felony offense in Iowa or any other state of the United States?

No

Has anyone listed on the Ownership page been convicted of any violation of any state, county, city, federal or foreign law? For traffic violations, only include those that are drug or alcohol related.

No

Criminal Violations

Contact Information

Contact Name: MELANIE OLSEN

Phone Number: (712) 898-3400

Email Address: melanie.olsen@oscarcarlviueyard.com

Address: 1473 BUCHANAN AVE SIOUX CITY IA 51106-5467

Attestation Information

Attestation Name: MELANIE OLSEN

Attestation Date: 14-Apr-2026

WOODBURY COUNTY AGENDA ITEM(S) REQUEST FORM

Date: 5/4/2026 Weekly Agenda Date: 5/12/2026

Elected Official / Department Head / Citizen: Michelle Skaff

Wording for Agenda Item:

Consideration and approval for liquor license for Correctionville Golf Club, Correctionville, IA.

Action Required:

Approve Ordinance

Approve Resolution

Approve Motion

Hold Public Hearing

Informational

Attachments

Set Time:

Reviewed by County Attorney's Office:

Background & Financial Impact:

N/A

Recommendation:

Approve motion

Attachments:

[Correctionville Golf Club](#)

Approved by Board of Supervisors on March 17, 2026

**Office Of The
AUDITOR/RECORDER
Woodbury County**
Michelle K. Skaff, Ph.D.
Auditor/Recorder/
Commissioner of Elections

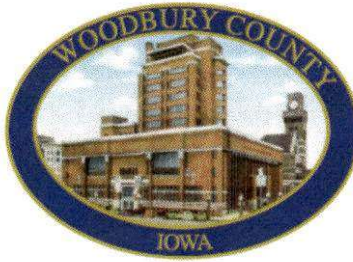

Courthouse – Room 103
620 Douglas
Sioux City, IA 51101

Phone: (712) 279-6702
Fax (712) 279-6629
miskaff@woodburycountyiowa.gov

To: Board of Supervisors

From: Michelle K Skaff, Auditor & Recorder

A handwritten signature in black ink, appearing to be "MKS", is written over the "From:" line.

Date: May 4, 2026

Subject: Liquor License Application for the Correctionville Golf Club, Correctionville, Iowa.

Please approve and receive for signature, an applicaton for a 12-month, Class C Retail Liquor License, with Outdoor Service, for the Correctionville Golf Club, Correctionville, Iowa. The license would be effective 06/02/26 through 06/01/27.

CLASS "C" RETAIL ALCOHOL LICENSE RENEWAL

Business Information

Name of Legal Entity: CORRECTIONVILLE GOLF CLUB INC

FEIN: XX-XXX6489

Business Type: Corporation

This business is registered with the Secretary of State.

Business Number of Secretary of State: 72112

Premises Information

Premises DBA: CORRECTIONVILLE GOLF CLUB INC

Premises Address: 1300 HACKBERRY ST CORRECTIONVILLE IA 51016

Premises Type: Golf Course

Number of Floors: 1

Control of Premises: Own

Is your premises equipped with at least one adequate, conveniently located indoor or outdoor toilet facility for use by patrons?

Yes

Does your premises conform to all local and state health, fire and building laws and regulations?

Yes

Is your establishment equipped with tables and seats to accommodate a minimum of 25?

Yes

Has the number of floors of the premises changed?

No

Have there been any changes to the premises in the last 12 months? This includes any changes that affect where alcohol is manufactured, stored, sold or consumed, such as adding, deleting, or changing permanent outdoor service areas.

No

Has there been a change in the control of property over the last 12 months? This includes a renewed/updated lease agreement, or changing from a deed to a lease, or a lease to a deed.

No

License Information

Effective Date: 02-Jun-2026

Length of License Requested: 12MONTH

Privilege(s) Requested

Outdoor Service - Allows the selling/serving of alcoholic beverages by the license/permit in a designated, adjacent outdoor area.

Provided description of the Outdoor Service Area:

SELLING THROUGHOUT THE GOLF COURSE.

Endorsements

Local Authority: Woodbury County

Dramshop Company: GRINNELL MUTUAL

Ownership Information

Type	Name	ID Type	ID	DOB	Phone	Address	Percentage
Individual	KELLY, ADAM	SSN	***-**-0958	21-Sep-19 87		4262 155TH ST CORRECTIO NVILLE IA 51016-8023	0.58
Individual	HEILMAN, AMANDA	SSN	***-**-6065	27-Feb-19 80		1510 MEGANS WAY CORRECTIO NVILLE IA 51016	0.01
Individual	EDWARDS, CORY	SSN	***-**-1065	14-Mar-19 76		3949 155TH ST CORRECTIO NVILLE IA 51016	0.58

Criminal History Details

Has anyone listed on the Ownership page been charged or convicted of a felony offense in Iowa or any other state of the United States?

No

Has anyone listed on the Ownership page been convicted of any violation of any state, county, city, federal or foreign law? For traffic violations, only include those that are drug or alcohol related.

No

Criminal Violations

Contact Information

Contact Name: AMANDA HEILMAN

Phone Number: (712) 372-4916

Email Address: cvillegolfclub@gmail.com

Address: 1300 HACKBERRY ST CORRECTIONVILLE IA 51016

Attestation Information

Attestation Name: AMANDA HEILMAN

Attestation Date: 25-Apr-2026

Collins, Patricia	Auditor	05-13-2026	Election Clerk – On Call	\$19.82/hour		A	Job Vacancy Posted on 4/20/26. Entry Level Salary: \$19.82/hr.
Collins, Richard	Auditor	05-13-2026	Election Clerk – On Call	\$19.82/hour		A	Job Vacancy Posted on 4/20/26. Entry Level Salary: \$19.82/hr.
Palsma, Kurtus	Secondary Roads	04-29-2026	Summer Engineering Aide- Temp	\$20.50/hour	2%=\$0.50/hr	O	Increase Requested by County Engineer

APPROVED BY BOARD DATE: _____

MELISSA THOMAS, HR DIRECTOR:

Melissa Thomas



Woodbury County Sheriff's Office

LAW ENFORCEMENT CENTER
P. O. BOX 3715 SIOUX CITY, IOWA 51102

CHAD SHEEHAN, SHERIFF

PHONE: 712.279.6010
E-MAIL: csheehan@woodburycountyiowa.gov
FAX: 712.279.6522

May 6, 2026

To the Woodbury County Board of Supervisors & Human Resources Department,

The Woodbury County Sheriff's Office respectfully requests discussion and action on the authorization to change employment classification for Dave Klocke from On-Call to Part-time. This change will have no budgetary effect and will allow Dave to work additional hours when needed. We request this be placed on the agenda for the Woodbury County Board of Supervisors meeting on May 12th, 2026. Thank you.

Sincerely,

A handwritten signature in black ink, appearing to read "Chad Sheehan".

Chad Sheehan, Sheriff

Cc: file

**HUMAN RESOURCES DEPARTMENT
WOODBURY COUNTY, IOWA**

DATE: May 12, 2026

AUTHORIZATION TO INITIATE HIRING PROCESS

DEPARTMENT	POSITION	ENTRY LEVEL	APPROVED	DISAPPROVED
Secondary Roads	Motor Grader Operator	CWA Roads: \$29.03/hour		

Chairman, Board of Supervisors

WOODBURY COUNTY AGENDA ITEM(S) REQUEST FORM

Date: 5/4/2026 Weekly Agenda Date: 5/12/2026

Elected Official / Department Head / Citizen: Ryan Ericson

Wording for Agenda Item:

FY27 Capital Improvement Requests 1. Auditor 2. Building Services 3. Bldg Svs/Juvenile Detention 4. Conservation 5. Siouxland District Health 6. Emergency Services 7. Secondary Roads 8. Sheriff 9. Treasurer 10. WCICC

Action Required:

Approve Ordinance

Approve Resolution

Approve Motion

Hold Public Hearing

Informational

Attachments

Set Time:

Reviewed by County Attorney's Office:

Background & Financial Impact:

Recommendation:

Attachments:

[Attachment 1](#)

Approved by Board of Supervisors on March 17, 2026

FY27 CIP Requests				
CIP Bond Issue (Debt Service Fund)				
Dept	Project Name	Original Amount	Current Amount	Misc Notes
Auditor	Carpet, Paint, Blinds, F, F & E for Auditor and Recorder	200,000	200,000	
Bldg Svs	Tri-View Parking Lot	5,000	5,000	
Bldg Svs	LEC Sign, Bus Shelter, Sidewalk	50,000	50,000	
Bldg Svs	Trosper-Hoyt Entrance, ADA Ramp, Facade	160,000	160,000	
Bldg Svs	Courthouse Wheelchair Lifts	162,000	162,000	
Bldg Svs/Juvenile Detention	Trosper-Hoyt JD specific repairs	225,000	225,000	
Conservation	Observation Deck	15,000	15,000	
Conservation	Retaining Wall	42,800	42,800	
Conservation	Water Fall, retaining wall, sidewalk	101,475	101,475	
District Health	HVAC	48,652	48,652	
EMS	Air Compressor	135,000	135,000	
EMS	Pickup/Plow	90,000	90,000	
EMS	Driveway	41,928	41,928	
EMS	Roof Maintenance	300,000	300,000	
Sec Rds	Real Estate for Hornick Shop	140,000	140,000	
Sheriff	Body Scanner	201,500	201,500	
Sheriff	Radio Equipment	106,809	106,809	
Treasurer	Anthon Office	34,274	34,274	
WCICC	Hyper-Converged Infrastructure Refresh	500,000	500,000	
WCICC	Multifuntions Printers & PCs	100,000	100,000	
Board	Loan Note Fees	20,000	20,000	
Total CIP Requests		2,679,438	2,679,438	

On 2-5-2025, \$200,000 was requested to fund the Auditor/Recorder Repairs, furniture, and fixtures from FY26 CIPs. The request was discussed again on 6-10-2025 at which time it was requested to work with Director Schmitz to provide a more detailed estimate. It was again discussed on 9-22-2025 in detail and was not approved for the FY26 budget.

FY27CIP request:

Recorder:

Reason: Provide better security, larger workspaces, and more efficient workflow. Additionally, to repair items in need.

Key project goals:

- * Open plan cubicles for 9 full time Staff
- * New secure entrance
- * Replace damaged front counter
- * Repair Window Seals and replace blinds
- * New public table and chairs
- * Repair and paint for floors and ceiling in vault area
- * Paint/antislip for stairs and railings
- * Repair/replace microfilm counter

Auditor Elections/Finance:

Reason: Provide better security, larger workspaces, and more efficient workflow. Additionally, to repair items in need.

Key project goals:

- * Open plan cubicles for 6 Full time Staff, 4 temporary staff, 1 secure workstation for elections
- * New Secure Entrance with key fob access
- * Secure front counter that mimics the historical counter in the Recorder's Office
- * Repair Window Seals and replace blinds
- * New Secure Room for elections with key fob access
- * one worktable area and one mail machine table

Diagram
County Auditor
Order Office

Office Furniture Options, Inc.
1803 4th Street, Sioux City, IA 51101

Case
Case
Chested
File
Top
Station

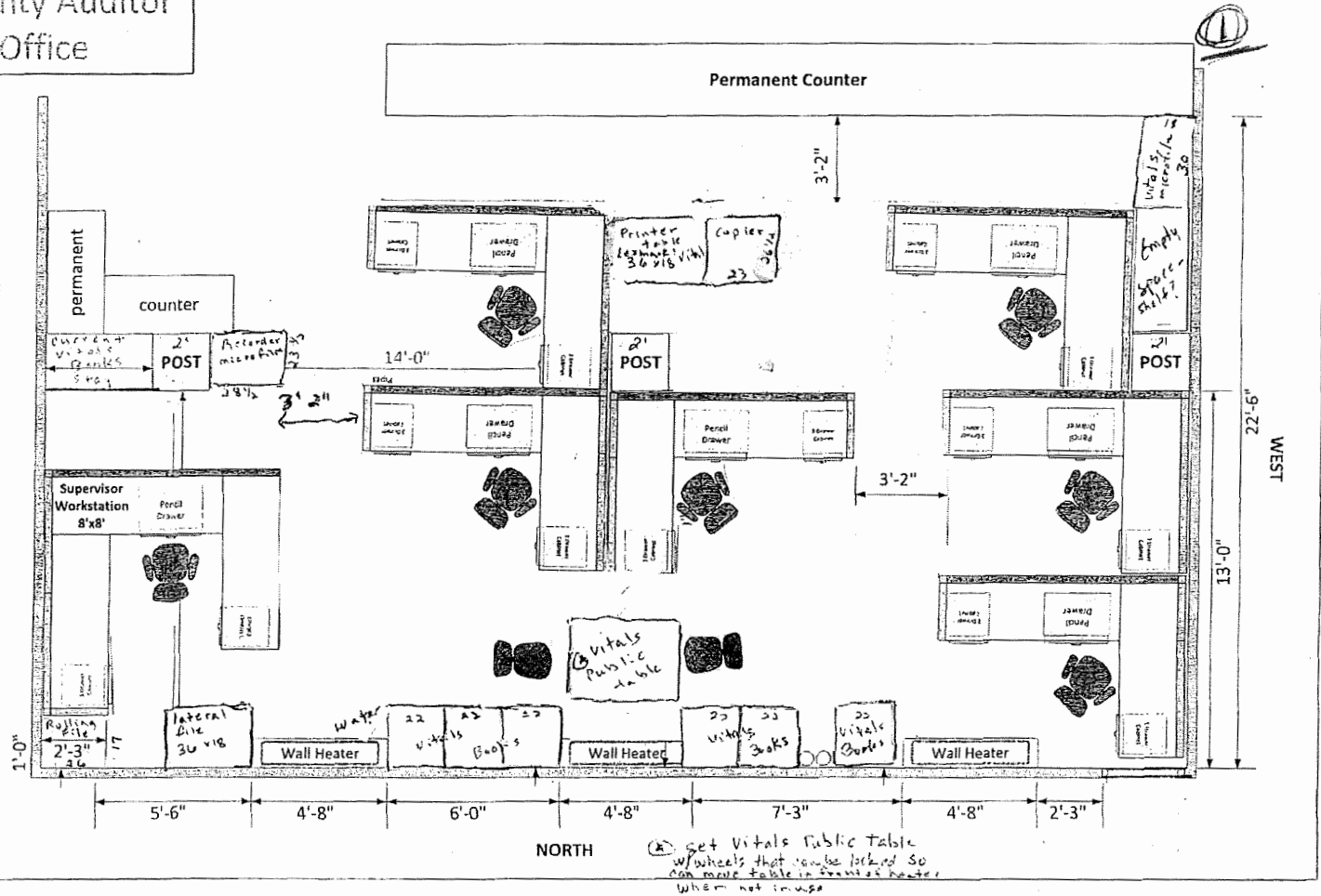

OFFICE ELEMENTS								
PRODUCT	MFG		QTY	New/ Used		\$ EACH		SUB-TOTAL
Cubicals								
Cubical 6'x 6' x 52"	Hon		1	New		\$3,441.78		\$3,441.78
Cubical 6'x 8' x 52"	Hon		7	New		\$3,333.74		\$23,336.18
Cubical 8'x 8' x 52"	Hon		1	New		\$3,883.64		\$3,883.64
Sit Stand Mechanics								
Delivery/ Installation			1			\$3,775.05		\$3,775.05
Electrical Circuitry Supply Wiring (Cubicals Infeed Power)			1			\$300.00		\$300
Data Circuits (Cubicals)			4			\$175.00		\$700
Interior Window Trim Repaint Throughout			18			\$60.00		\$1,080
Interior Window Blinds Replacement			18			\$423.00		\$7,614
Interior Window Seal Replacement			18			\$325.00		\$5,850
Repaint HVAC Fan Coil Units			6			\$850.00		\$5,100

OFFICE ELEMENTS								
PRODUCT	MFG	QTY	New/ Used			\$ EACH		SUB-TOTAL
CUBICALS / DESKS								
Cubicle 6'x 8' x 52" GL	Hon	9	New			\$3,333.74		\$30,003.66
Cubicle 8'x 8' x 52" GL	Hon	1	New			\$3,883.64		\$3,883.64
6' X 6'	Hon	1	New			\$3,441.78		\$3,441.78
Sit Stand Mechanics								
Tall Walls 11' X 12' X 8	Hon	1	New			\$2,000		\$2,000.00
Delivery/ Installation		1				\$4,815.05		\$4,815.05
Electrical Circuitry								
Supply Wiring (Cubicals Infeed Power)								
		6				\$1,160.00		\$6,960.00

CIP – NEW PROJECT REQUEST FORM

Project Name: Tri-View

Project Number: (Finance will provide number)

Project Manager: Building Service Kenay Schmitz

Department/Division: Building Services

	<u>Year 1</u>	<u>Year 2</u>	<u>Year 3</u>	<u>Year 4</u>	<u>Year 5</u>	<u>Total</u>
Revenues						
Total Revenues						

Expenditures

<u>Parking Lot striping & Concrete Repair</u>						
Total Expenditures						<u>\$5,000</u>

Comments:

CIP – NEW PROJECT REQUEST FORM

Project Name: LEC - SIGNAGE, BUS STOP SHELTER, & SIDEWALK

Project Number: _(Finance will provide number)_

Project Manager: Kenny Schmitz

Department/Division: BUILDING SERVICES

	<u>Year 1</u>	<u>Year 2</u>	<u>Year 3</u>	<u>Year 4</u>	<u>Year 5</u>	<u>Total</u>
<u>Revenues</u>						
_____	_____	_____	_____	_____	_____	_____
_____	_____	_____	_____	_____	_____	_____
_____	_____	_____	_____	_____	_____	_____
_____	_____	_____	_____	_____	_____	_____
_____	_____	_____	_____	_____	_____	_____
_____	_____	_____	_____	_____	_____	_____
_____	_____	_____	_____	_____	_____	_____
_____	_____	_____	_____	_____	_____	_____
Total Revenues	_____	_____	_____	_____	_____	_____

Expenditures

<u>LEC SIGN</u>	<u>\$19,000</u>	_____	_____	_____	_____	_____
<u>BUS SHELTER/PAD</u>	<u>#18,000</u>	_____	_____	_____	_____	_____
<u>SIDEWALK - (FROM LEC TO AGARD)</u>	<u>#??</u>	_____	_____	_____	_____	_____
_____	_____	_____	_____	_____	_____	_____
_____	_____	_____	_____	_____	_____	_____
_____	_____	_____	_____	_____	_____	_____
Total Expenditures	_____	_____	_____	_____	_____	_____

Comments:

- ① Have received complaints of no signage
- ② Public needs a shelter after release
- ③ City of Sioux City may require a sidewalk



TROSPER - HOYT COUNTY SERVICES BUILDING

822 DOUGLAS

MOTO
DEPAR

822



8-4-20

PROPERTY TAX
MOTOR VEHICLE, DMV
STRAIGHT AHEAD

CIP – NEW PROJECT REQUEST FORM

Project Name: Courthouse - Wheelchair Lifts (Both)

Project Number: (Finance will provide number)

Project Manager: Kenny Schmitz

Department/Division: Building Services

	<u>Year 1</u>	<u>Year 2</u>	<u>Year 3</u>	<u>Year 4</u>	<u>Year 5</u>	<u>Total</u>
Revenues						
_____	_____	_____	_____	_____	_____	_____
_____	_____	_____	_____	_____	_____	_____
_____	_____	_____	_____	_____	_____	_____
_____	_____	_____	_____	_____	_____	_____
_____	_____	_____	_____	_____	_____	_____
_____	_____	_____	_____	_____	_____	_____
_____	_____	_____	_____	_____	_____	_____
_____	_____	_____	_____	_____	_____	_____
_____	_____	_____	_____	_____	_____	_____
Total Revenues	_____	_____	_____	_____	_____	_____

Expenditures

MAIN ENTRANCE \$75,000

LOWER LEVEL \$75,000

ARCHITECT/ENG \$12,000

Total Expenditures \$162,000

Comments: ADA/SAFETY

MAIN ENTRANCE chair lift will not accommodate larger chairs/sizes
LOWER-LEVEL LIFT HAS been tagged out of service by
state inspector and it must be replaced.

TROSPER-HOYT JUVENILE DETENTION

Holding Cells

- a. Remove Existing Floor Tile Floors/ Wallbase
- b. Clean, Prepare, & Repaint all Ceilings
- c. Repair Concrete Block Walls, Primer & Repaint All Walls
- d. Replace Flooring with Epoxy Coat Paint, Replace Wallbase
- e. Cells (2) Replace Detention Stainless Steel Combi-Units (toilet/sink)

Restrooms/ Showers (3 total)

- a. Demo Interior All- Walls, Floors, Ventilation/ Exhaust Ducts, Shower Plumbing Fixtures & Controls, Lights, Combi-Units
- b. Install Pre-Engineerd Shower/ Restroom Exhaust Systems Ductwork, Fans, Controls, & Finished Exhaust/ Supply Grills
Repair, Clean, Primer, & Paint Ceilings
- c. Install Engineered Specified Structural Shower Wall Assemblies
- d. Replace Shower Plumbing Lines, Shower Head Fixtures & Controls
- e. Finish Shower Walls with Engineered Specifed Stainless Steel Panel Assemblies
- f. Install Engineer Specified LED Light Fixtures
- g. Install Epoxy Coat Paint to all Restroom & Shower Floors, Install Wallsbase
- h. Install (3) Detention Stainless Steel Combi-Units (toilet/sink)

Gymnasium

- a. Clean, Primer & Repaint Ceiling
- b. Repair Concrete Block Walls, Primer & Repaint All Walls, Replace Wallbase
- c. Strip, Multi-Wax & Seal Existing Tile Floor

Suicide Watch Room

- a. Repair Ceiling, Clean, Primer, & Paint Ceiling
- b. Repair Concrete Block Walls, Primer & Repaint All Walls

Exterior Roof

- a. Replace Roof in & Around Perimeter of Detention Excesize Area

Secondary Control

- a. Demo 42" of Concrete Block Wall, Countertop, & Worksurface
- b. Demo Laminate Casework- Countertops, Work Sufaces, & Drawers
- c. Install New Casework with Corian Work Sufaces & Countertops
- d. Repair/ Finish Flooring in Demo Areas

Detention Day Room

- a. Repair Ceiling, Clean, Primer, & Paint Ceiling
- b. Replace All HVAC Grills
- c. Repair Walls, Primer & Repaint All Walls, Replace Wallbase

Dention Security Systems

- a. Replace Accurate Control System (minimum 25- camera) & Software
- b. Demo Existing Camera Systems Coaxial Cable & Connections
- c. Install New Camera Systems Data Cable Cat-6A Wiring
- d. Install New High Defintion Cameras (Minimum 25)

CIP – NEW PROJECT REQUEST FORM

Project Name: Observation Deck – Concrete Replacement _____

Project Number: _(Finance will provide number)_____

Project Manager: Dan Heissel

Department/Division: Conservation

	<u>Year 1</u>	<u>Year 2</u>	<u>Year 3</u>	<u>Year 4</u>	<u>Year 5</u>	<u>Total</u>
<u>Revenues</u>						
_____	_____	_____	_____	_____	_____	\$0
_____	_____	_____	_____	_____	_____	_____
_____	_____	_____	_____	_____	_____	_____
_____	_____	_____	_____	_____	_____	_____
_____	_____	_____	_____	_____	_____	_____
_____	_____	_____	_____	_____	_____	_____
Total Revenues	_____	_____	_____	_____	_____	\$0

Expenditures

__Remove concrete on deck and replace, remove bridge to deck and replace with dirt and culvert with sidewalk that is Handicap Accessible. _____

Total Expenditures _____ \$15,000

Comments:

Remove concrete on observation deck leaving the perimeter intact with railing. Jack hammer and load old concrete and load into truck provided. Grade and pour back a 6" slab with broom finish and 24" fiberglass rebar mat. Remove bridge to deck and assist in replacing with culvert provided by owner, form and pour 6" x 8' sidewalk connecting parking lot to deck approximately 24' in length. Previous administration had cut and ground this deck down and poured a thin layer of colored and stamped concrete. This is heaving and busting up and we have had it repaired 2 to 3 times and we continue to have the problem. This becomes a tripping liability and a slipping issue. By cutting out and replacing we will get rid of ramp as well which allows us to install a handicap accessible sidewalk to connect to lower sidewalk. Mark and Dave have seen this issue.

CIP – NEW PROJECT REQUEST FORM

Project Name: Retaining Wall Replacement at Nature Center

Project Number: __(Finance will provide number)_____

Project Manager: Dan Heissel

Department/Division: Conservation

	<u>Year 1</u>	<u>Year 2</u>	<u>Year 3</u>	<u>Year 4</u>	<u>Year 5</u>	<u>Total</u>
<u>Revenues</u>						
_____	_____	_____	_____	_____	_____	\$0
_____	_____	_____	_____	_____	_____	_____
_____	_____	_____	_____	_____	_____	_____
_____	_____	_____	_____	_____	_____	_____
_____	_____	_____	_____	_____	_____	_____
_____	_____	_____	_____	_____	_____	_____
Total Revenues	_____	_____	_____	_____	_____	\$0

Expenditures

94 feet of 10 inch thick stone faced concrete wall with 12 foot returns for stability with 24 inch by 12 inch footing underneath
\$42,824.00

Total Expenditures _____ \$42,800.00

Comments:

The brick retaining walls for the gardens are collapsing and starting to lean and are ready to fall over at the Nature center and are not safe. The plan is to tie into the poured wall near the shelter area and stair step the wall down replacing the existing block walls with a poured wall using stone faced forms for looks. This project will include the following work; Extend existing 9' wall 36' with 12' returns for stability of ground and wall. Skipp stairway and then do a 32' x5' wall and a 26'x5' wall making the terrace for the flower garden up to the parking lot, all having 12' returns for stability of wall and ground. Estimated 3 returns for each section of wall. Walls will have 10" thickness with stone faced forms to match existing wall. There will be a 24" x 12" footing underneath wall with 2 runs of horizontal rebar. I have gotten a bid on this project so I know this is an accurate number. This will be done the same way we did for the retaining wall for the shelter and it has worked great. Mark and Dave have seen this issue.

CIP – NEW PROJECT REQUEST FORM

Project Name: Water fall Retaining wall, sidewalk, steps and railings replacement

Project Number: _(Finance will provide number)_____

Project Manager: Dan Heissel

Department/Division: Conservation

	<u>Year 1</u>	<u>Year 2</u>	<u>Year 3</u>	<u>Year 4</u>	<u>Year 5</u>	<u>Total</u>
<u>Revenues</u>						
_____	_____	_____	_____	_____	_____	0
_____	_____	_____	_____	_____	_____	
_____	_____	_____	_____	_____	_____	
_____	_____	_____	_____	_____	_____	
_____	_____	_____	_____	_____	_____	
_____	_____	_____	_____	_____	_____	
Total Revenues	_____	_____	_____	_____	_____	0

Expenditures

____Remove two retaining walls, steps, sidewalk, handrail, hardscape and railroad tie steps and build two new keystone block retaining walls. Geo grid will be placed as this is being built back up to keep this from happening again \$101,475

_____	_____	_____	_____	_____	_____	
_____	_____	_____	_____	_____	_____	
Total Expenditures	_____	_____	_____	_____	_____	<u>\$101,475.00</u>

Comments:

I have an updated bid on this project where I got this pricing from, so it is current. Mark and Dave have seen this project and how bad it looks and the fact it is not getting any better. This needs to be replaced to remove liability along with how bad it looks for the county. This has become a liability as well as an eyesore and needs to be taken care of ASAP. This area needs to be excavated and built back up with GEO Grid to keep it from happening again. This is highly visible and part of the nature Centers viewing area and it looks terrible. We have had architects and Civil engineers look at this and have a good game plan on how to fix and make useable again.

CIP – NEW PROJECT REQUEST FORM

Project Name: **HVAC Controls Replacement**

Project Number: _(Finance will provide number)_____

Project Manager: **Tyler Brock**

Department/Division: **Siouxland District Health Department**

	<u>Year 1</u>	<u>Year 2</u>	<u>Year 3</u>	<u>Year 4</u>	<u>Year 5</u>	<u>Total</u>
<u>Revenues</u>						
CIP	\$48,652	_____	_____	_____	_____	_____
_____	_____	_____	_____	_____	_____	_____
_____	_____	_____	_____	_____	_____	_____
_____	_____	_____	_____	_____	_____	_____
_____	_____	_____	_____	_____	_____	_____
Total Revenues	_____	_____	_____	_____	_____	_____

<u>Expenditures</u>						
_____	_____	_____	_____	_____	_____	_____
_____	_____	_____	_____	_____	_____	_____
_____	_____	_____	_____	_____	_____	_____
_____	_____	_____	_____	_____	_____	_____
Total Expenditures	_____	_____	_____	_____	_____	_____

Comments:

This project is needed due to aging HVAC controls that have exceeded their useful life and are no longer functioning correctly. These controls were from Johnson Controls and were never replaced when many other controls were switched to Star Controls. The automation is non-existent in much of our building due to the controls failing and the main air handling unit is also not functioning consistently due to faulty controls.

Ryan Ericson

From: Tyler Brock
Sent: Monday, May 4, 2026 3:45 PM
To: Ryan Ericson
Subject: RE: CIP Schedule

Ryan,

FYI on our CIP request. We got a grant that will cover \$25,000 of our request. That will leave only \$24,652 remaining on the requested HVAC repair project.

Let me know if you need anything else. Thanks.

Tyler

Tyler Brock

Deputy Director and Director of Laboratory Services

Siouxland District Health Department

1014 Nebraska St Sioux City, IA 51105

Ph: 712-279-6119 | Mobile: 712-490-0689

tbrock@siouxlanddistricthealth.org

Visit us at: www.siouxlanddistricthealth.org



From: Ryan Ericson <rericson@woodburycountyiowa.gov>

Sent: Wednesday, April 15, 2026 12:04 PM

To: Heather Satterwhite <hsatterwhite@woodburycountyiowa.gov>; Mark Nelson <mnelson@woodburycountyiowa.gov>; David Dietrich <ddietrich@woodburycountyiowa.gov>; Laura Sievers <lsievers@woodburycountyiowa.gov>; Michael Montino <mmontino@woodburycountyiowa.gov>; Chad Sheehan <csheehan@woodburycountyiowa.gov>; Melissa Thomas <melissathomas@woodburycountyiowa.gov>; Tyler Mogensen <tmogensen@woodburycountyiowa.gov>; John Malloy <jmalloy@wcicc.com>; Michelle Skaff <miskaff@woodburycountyiowa.gov>; Daniel Heissel <dheissel@woodburyparks.org>; Daniel Priestley <dpriestley@woodburycountyiowa.gov>; Loni Kuhlmann <lkuhlmann@woodburycountyiowa.gov>; Cathy Warner <cwarner@woodburycountyiowa.gov>; James Loomis <jloomis@woodburycountyiowa.gov>; Ryan Weber <rweber@woodburycountyiowa.gov>; Drew Baier <dbaier@woodburycountyiowa.gov>; Kevin Grieme <kgrieme@siouxlanddistricthealth.org>; Tina Bertrand <tbertrand@woodburycountyiowa.gov>; Kenny Schmitz

CIP – NEW PROJECT REQUEST FORM

Project Name: Woodbury County Emergency Services CIP 5 year plan FY 27-FY31

Project Number: _(Finance will provide number)

Project Manager: Drew Baier Director

Department/Division: 0002-41-1200-0000

	<u>Year 1</u>	<u>Year 2</u>	<u>Year 3</u>	<u>Year 4</u>	<u>Year 5</u>	<u>Total</u>
<u>Revenues</u>						
_____	_____	_____	_____	_____	_____	_____
_____	_____	_____	_____	_____	_____	_____
_____	_____	_____	_____	_____	_____	_____
Total Revenues	_____	_____	_____	_____	_____	_____

<u>Expenditures</u>	<u>FY 26/27</u>	<u>FY 27/28</u>	<u>FY 28/29</u>	<u>FY 29/30</u>	<u>FY 30/31</u>	
Replace Air Comp.	\$135,000	_____	_____	_____	_____	\$135,000
Replace pickup/plow	\$90,000	_____	_____	_____	_____	\$90,000
Replace Driveway	\$41,928	_____	_____	_____	_____	\$41,928
Replace Roof Main	\$300,000	_____	_____	_____	_____	\$300,000
Replace 2 Monitors	_____	\$115,000	_____	_____	_____	\$110,000
Replace 2 Lucas Dev	_____	\$40,000	_____	_____	_____	\$40,000
Replace Rescue Truck	_____	\$115,000	_____	_____	\$125,000	\$240,000
Ambulance (New)	_____	_____	\$500,000	_____	_____	\$500,000
Replace Riding Mower	_____	_____	_____	\$25,000	_____	\$25,000
Total Expenditures	\$566,928	\$270,000	\$500,000	\$25,000	\$125,000	\$1,481,928

Comments:

Scope of Work (supplemental)

Roof Areas Insulation

A & B = Provide two (2) layers of 3" ISO over existing insulation assembly.

C, D, E, F, & G = Provide one (1) layer of 1/2" Dens-Deck or SecuRock cover-board.

1. Install new wood blocking as needed to accommodate installation.
2. Remove and replace all gutters and downspouts.
3. Remove all existing terracotta coping.
4. Install new wood blocking as needed at parapet walls to accommodate new sheet metals.
5. All new sheet metals to be min. 24ga. prefinished metals.
6. Replace damaged or missing drain strainers as needed.
7. Use polymer wood blocking at all exposed lumber locations.

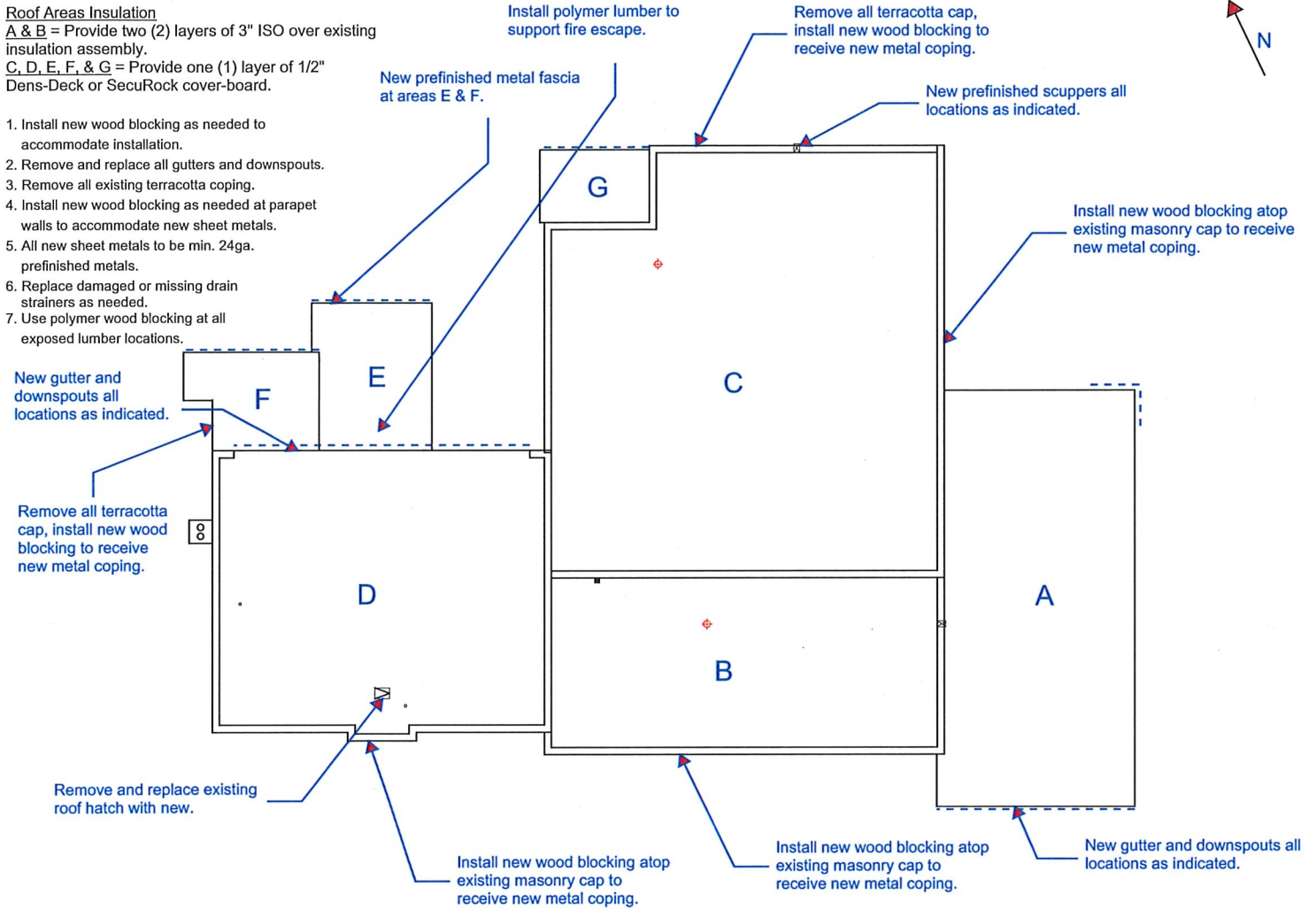

Woodbury County Dispatch 121 Deer run Trail Climbing Hill, IA 51015

Core Cut Samples

- A. Mil Deck, 1.5" WdFb, BUR w/Gravel, 1.5" ISO, EPDM-A
- B. Wd Deck, CTP BUR, 2" ISO, EPDM-A
- C. Wd Deck, 4" ISO, EPDM-A
- D. Wd Deck, BUR, 1.4" ISO, EPDM-A
- E. Wd Deck, .5" FB, EPDM-B
- F. Wd Deck, RR, 1.5" ISO, EPDM-A
- G. Wd Deck, 1.5" ISO, EPDM-A

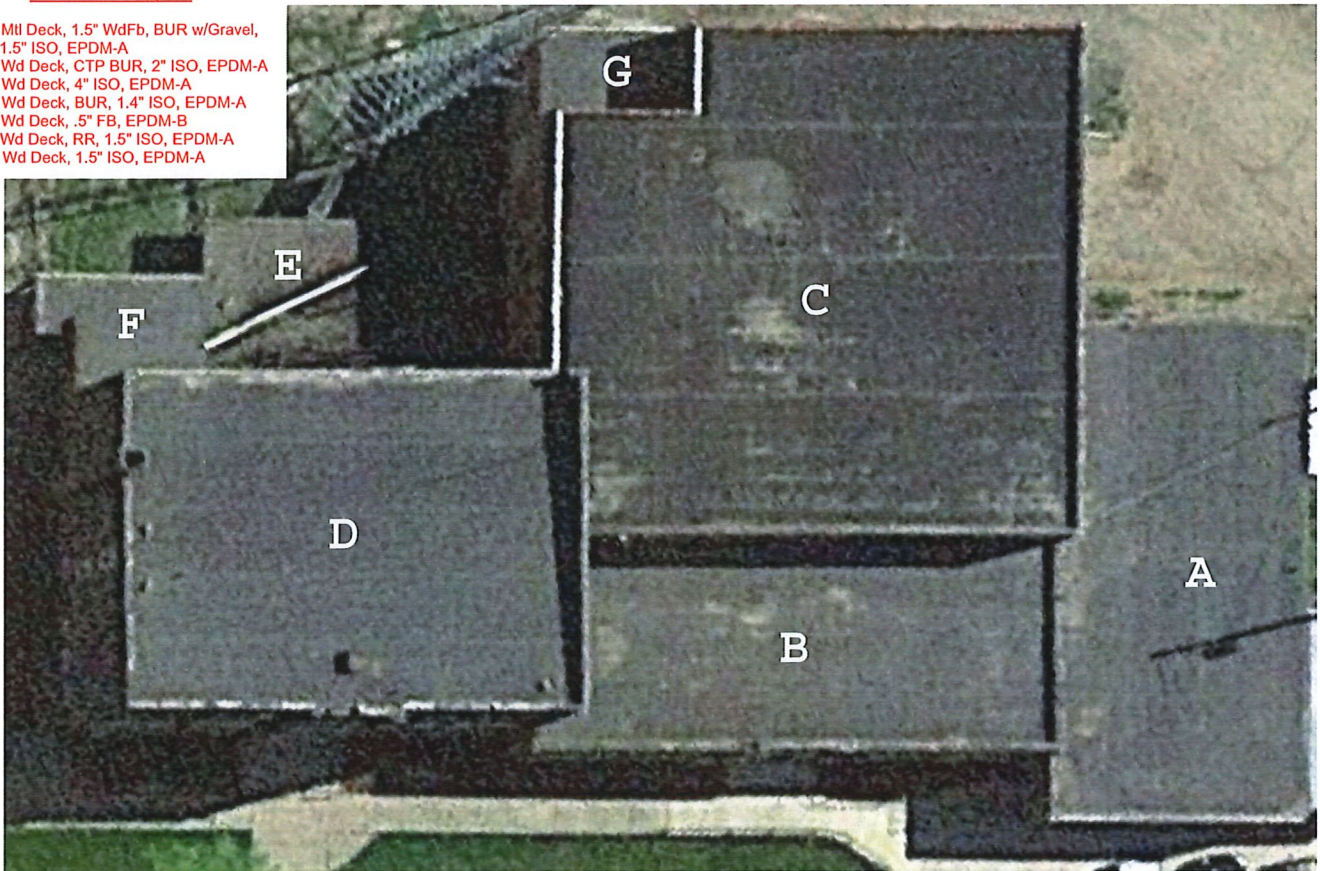

CIP – NEW PROJECT REQUEST FORM

Project Name: District 5 Hornick Secondary Road Maintenance Facility

Project Number: *(Finance will provide number)*

Project Manager: County Engineer, Laura Sievers, PE

Department/Division: Secondary Roads

	<u>Year 1</u>	<u>Year 2</u>	<u>Year 3</u>	<u>Year 4</u>	<u>Year 5</u>	<u>Total</u>
<u>Revenues</u>						
Old Shop/Property				\$75,000		\$75,000
Culvert Storage			\$20,000			\$20,000
Gravel Storage			\$20,000			\$20,000
Total Revenues			\$40,000	\$75,000		\$115,000
<u>Expenditures</u>						
7 acres	\$140,000					\$140,000
Site Development		\$50,000				\$50,000
Main Building		\$4,000,000				\$4,000,000
Cold Storage			\$200,000			\$200,000
Sand/Salt Storage			\$30,000			\$30,000
Total Expenditures	\$140,000	\$4,050,000	\$230,000			\$4,420,000

Comments: Project information on following pages.

Secondary Roads Capital Improvement Program

Existing Conditions

The relocation and replacement of the Hornick Maintenance Facility is requested by the Secondary Roads Department. The building, constructed in 1969, is one of the oldest Secondary Roads facilities and has received only one upgrade since its original construction, a window air conditioner unit. With savings throughout the past 57 years, the deferred maintenance repairs overtime have accelerated the deterioration of the facility, resulting in safety concerns and operational inefficiencies.

The existing property for the Hornick Maintenance Facility is small, so storage of culverts and other materials are located offsite north of Hornick and at Holly Springs. For efficiency and security of the materials, it would be beneficial to get stockpiled material where equipment to handle it is located. All the properties have adjacent landowners interested in purchasing if the new facility is relocated.

The following photos document the current condition of the Hornick Maintenance Facility and highlight some of the deficiencies below. The photographs provide a snapshot of conditions but do not fully convey the extent of deterioration. An on-site visit is the best way to understand the challenges faced by County staff working at this facility.

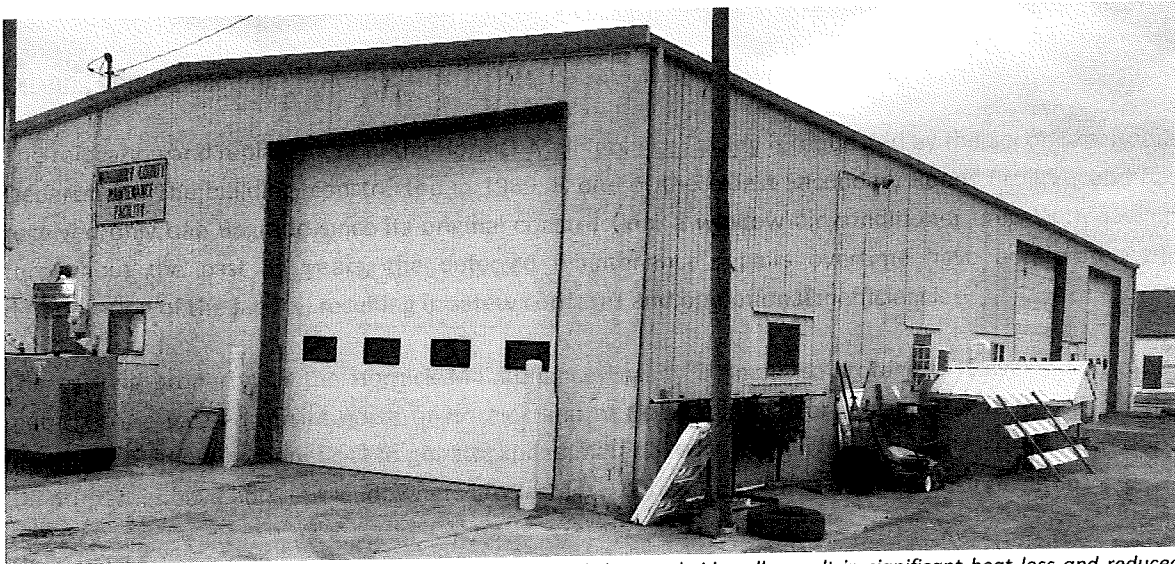

Hornick Maintenance Facility – Large gaps between overhead door and sidewalls result in significant heat loss and reduced efficiency during winter operations.

With limited overhead doors, equipment is usually scraping the door frames as the equipment squeezes into the facility. One plow needs to be removed daily in the winter months, so all the trucks fit inside overnight.

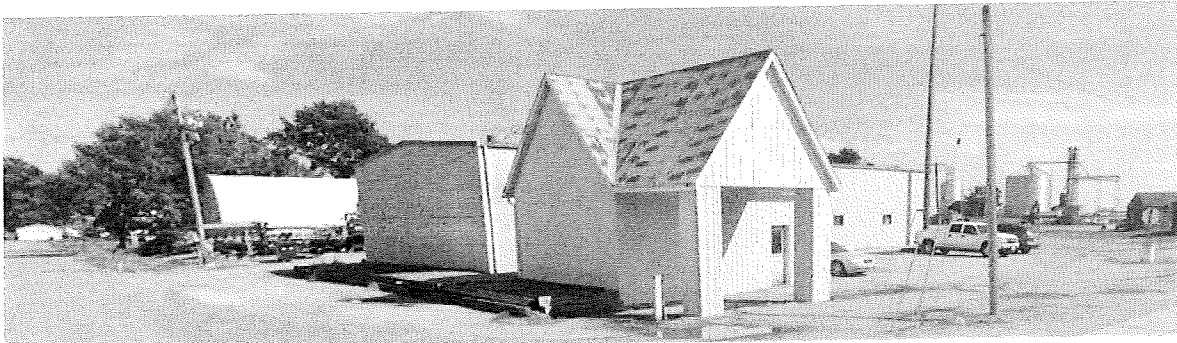

700-ft storage building is too small

The storage building is used to house the bulk purchased tires. With only a walk-in door, all materials stored in the building are moved by staff and not equipment. The cold storage building cannot house the sign trailer that is set up for emergency closures of roadways. This also means the signs sit outside 365 days of the year and quickly diminish their useful life from the sun. The pickups, semi, trailer, loader, and at times the skid steer are parked outside due to the existing facilities not being large enough to house all the equipment used in District 5.



Makeshift Conference Room/Breakroom – employees sit next to snow equipment, does not allow for adequate safety meetings.

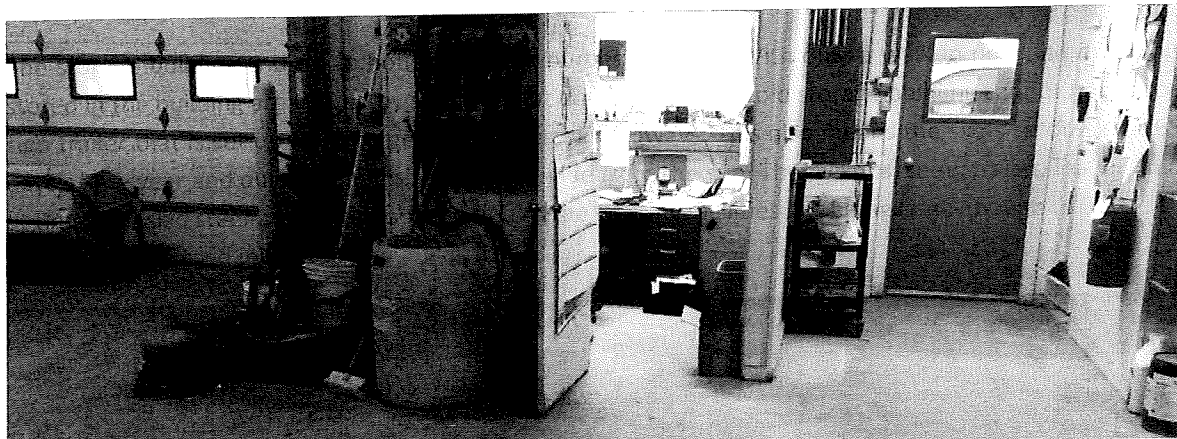

Closet space has been used as Office/Document Storage - limited office and document storage space.

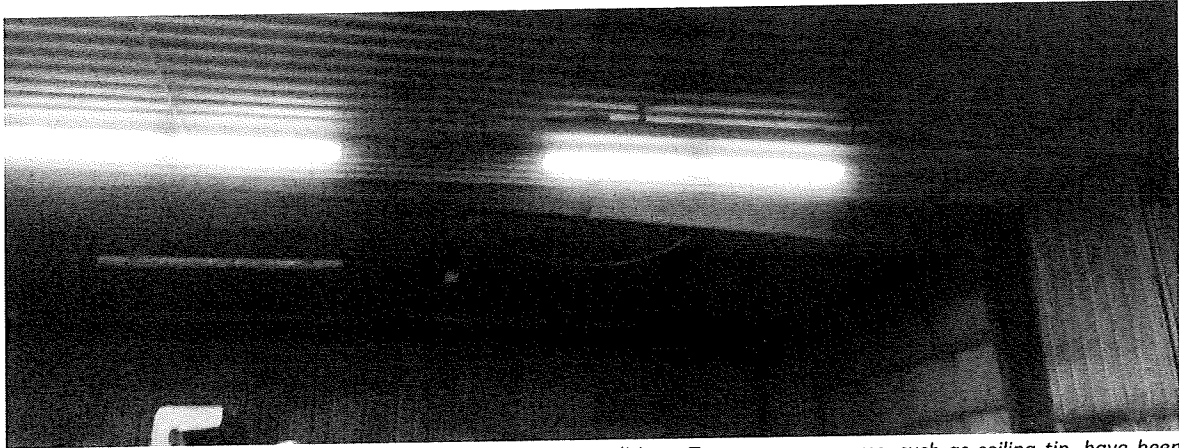

Inadequate, insufficient lighting impacts safety and working conditions. Temporary measures, such as ceiling tin, have been installed to divert rainwater and prevent damage to electrical overhead door components.



Ongoing roof leaks and deteriorated insulation contribute to structural decline and unsafe conditions.

These conditions directly impact employee safety, morale and equipment longevity.

Proposed New Facility

A new Maintenance Facility in Hornick is justified due to the numerous inadequacies of the existing building and would help address:

- A. **Location:** Residential neighborhood complaints about the 5 AM loading of sand/salt material. A new location would be outside the residential neighborhood.
- B. **Employee Needs:** Lack of adequate space for documentation storage for the district. No designated break room to conduct safety meetings and employee lockers. A small, designated room would meet this need.
- C. **Electrical Issues:** The electrical does not fully support all the needs and the equipment in the building. A new facility would provide Code compliant electrical work.

- D. **Storage:** Insufficient space for bulk oil and DEF systems. Inadequate door opening to use equipment to move heavy tires. No room for storage of emergency road closure signs. Either a separate storage building or a bit larger main facility would provide adequate storage for all equipment, tires, signs, etc.
- E. **Size:** The current building is too small, and not all equipment can be housed indoors. The size of road equipment has changed significantly since the building was originally constructed. Pictured below is a comparison of the 1960's motor grader to the size of ones the County is using today. The minimum truck with snowplow equipment bay and motor grader bay would be 60-ft x 22-ft.

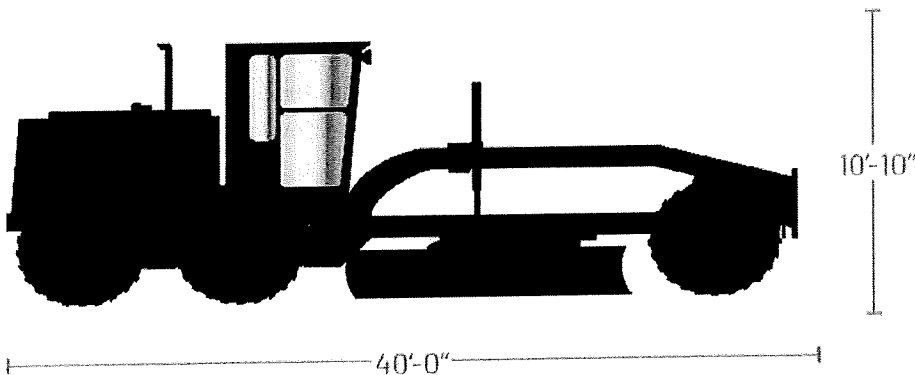
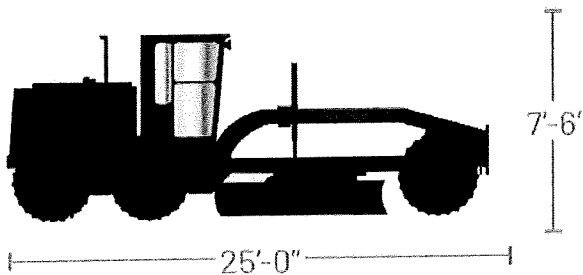

- F. **Heating:** Due to significant roof failures and damaged insulation throughout the building, the existing heating system is unable to maintain adequate temperatures during winter weather to fully melt and dry the snow and ice off the equipment before the next day of work.
- G. **Vehicle Washing:** There is no wash bay, forcing vehicles to be washed outside in poor weather or not at all because of freezing temperatures, accelerating equipment wear. The minimum specialty bays for washing and maintenance would be 80-ft x 34-ft with a 27-ft height clearance.

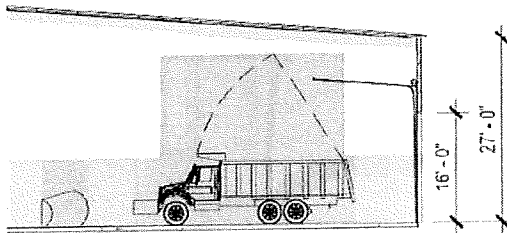

H. **Maintenance:** With no mechanic's bay, equipment being repaired requires even more equipment stored outside when there are delays in repairs while waiting for parts and available workspace. The ceiling is too low to lift equipment needing repaired, which limits the ability to repair equipment and to see all the issues with the equipment. Adequate space around equipment for repair work and cleaning of equipment is shown below:

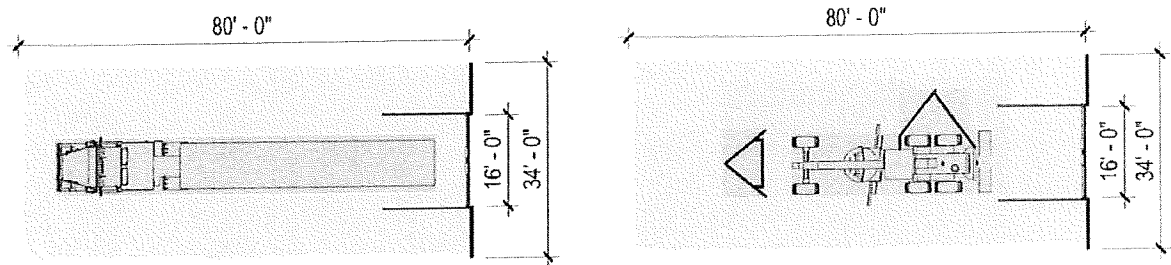

I. **Structural Issues:** The roof leaks, sidewalls are rusted through, large gaps between the overhead doors and frames, and the floor around the drain is eroding. A new, well-maintained building would resolve all these problems.

Other counties, including Dickinson County, have recently invested in modern Secondary Roads facilities, including a maintenance facility in Spirit Lake constructed in 2021. While costs vary based on size and features, these projects demonstrate the ongoing need for counties to replace aging infrastructure. Based on current construction costs and the operational needs of Woodbury County, a building cost in the range of \$4,000,000 is a reasonable and supportable estimate.

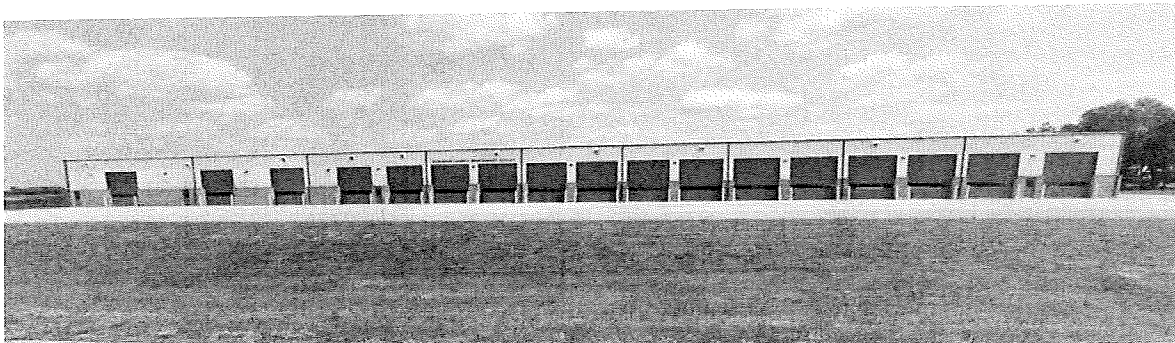

Dickinson County 2021

Open Invite to Tour

The Board of Supervisors and Finance Director are encouraged to visit the Hornick Maintenance Facility to observe these conditions firsthand. The deficiencies outlined above are readily apparent and underscore the need for investment in a modern, functional facility. Decades of minimal investment in this facility have deferred costs to the present, where replacement is now the most practical and cost-effective solution.

IMPROVEMENT REQUEST

Department/Division Title: Woodbury County Sheriff's Office – Jail division

Request: Te84 intercept whole body scanner. Our current body scanner was purchased in 2018 and the manufacturer no longer produces this model and replacement parts are becoming obsolete and difficult to find, not to mention finding someone who is able to perform maintenance on the scanner. Software updates are no longer available or supported. If and when something breaks, we will lose a critical security component to detect contraband and to ensure the safety of our staff.

Justification: Continued reliance on unsupported and obsolete equipment increases liability exposure and undermines jail security operations. Failure of this system would require a return to less effective and more labor-intensive screening methods, increasing staffing demands and safety risks.

Financial Impact:

Te84 intercept body scanner - \$139,000

Shipping -\$2,500

5 year warranty - \$40,000

Thermal scanner - \$20,000

Total financial impact \$201,500

Budget Account Detail

Account Number:	Description:	Amount:	Explanation:
0001-05-1050-000-63600	jail machinery/equipment	\$201,500	New body scanner
Total:		\$201,500	

IMPROVEMENT REQUEST

Department/Division Title: Woodbury County Sheriff's Office – Jail division

Request:

- 120 Motorola R5 portable radios \$82,800,
- 120 Radio mic's \$11,520
- 15 multi-chargers \$8,175
- 24 desktop chargers \$1,656
- 3 inch fixed loop cases \$2,640
- 1 program cable \$18

Justification: Our jail staff has been using the same portable radios for approx. 15 years and the wear and tear is starting to catch up. We are constantly buying replacement parts on Amazon and Motorola does not manufacture our current radio's any longer. In some cases our current radios sustain damage, where the cost to repair exceeds the cost to replace. Our current radios are no longer providing the level of reliability, which puts our correctional staff at risk. The radio system is used for a variety of duties to include jail operation, building security, entrance security, and all court security functions. The reliability of our current radios have come in question during the most recent protest, which occurred in the LEC parking lot. We currently have a very robust radio infrastructure in place within the building, however, the ageing radios have become increasingly unreliable. Some of the issues we have are battery life, lapel mic's that disconnect or will not transmit, radio power cycling unexpectedly, leaving our staff in a vulnerable and unsafe situation. We are in need of a dependable solution with the Correction's Officer's safety in mind.

Financial Impact: Total replacement cost for listed items above: \$106,809.00

Budget Account Detail

Account Number:	Description:	Amount:	Explanation:
0001-05-1050-000-44600	Repair/Maint. Radio & related	\$106,809	Radio & Equipment
Total:		\$106,809	

CIP – NEW PROJECT REQUEST FORM

Project Name: Anthon office updates and repairs

Project Number: (Finance will provide number)

Project Manager: Tina Bertrand

Department/Division: Treasurer's Department

	<u>Year 1</u>	<u>Year 2</u>	<u>Year 3</u>	<u>Year 4</u>	<u>Year 5</u>	<u>Total</u>
Revenues						
CIP Loan	34274.13					
Total Revenues						

Expenditures						
CIP - replace ext doors	11264.50					
CIP-R&R concrete sidewalk	5460.62					
CIP-repaint exterior brick	3505.41					
CIP - caulk windows	328.57					
CIP-Int misc repairs, updates, paint	7861.18					
CIP-R&R carpet	5853.85					
Total Expenditures	34274.13					

Comments: See attached detail

FY27 CIP Project
 Anthon Courthouse Repairs Updated Estimates

Contractor	Description of work	6/23/25 bid	Increased by 10%
Sands Construction	Purchasing 2 galvanized commercial door's and jambs with all new hardware, demoing existing doors and installing new	10,240.45	11,264.50
Sands Construction	Demoing the existing 305 sf of concrete next to building and in front of main door and forming up and pouring back in #4000 limestone	4,964.20	5,460.62
Sands Construction	Fixing all holes in mortar joints and painting exterior back and one side of building	3,186.74	3,505.41
Sands Construction	Recaulking 9 exterior windows	298.70	328.57
Sands Construction	Fixing ceiling inside main entry and in back, recaulking crown mold and painting entire inside of building except for restroom and offices, painting front reception area below countertop and 4 door's and set of bi-fold door's in a gray color with the rest being painted white	7,146.53	7,861.18
Flooring MDs Carpet One	Carpet replacement	5,321.68	5,853.85
		31,158.30	34,274.13

Sands Construction
Ryan (712)898-7811
Union Trained
Insured & Bonded



Date: 6/23/25

Job Number: 0004091 Anthon Court House

Purchasing 2 galvanized commercial door's and jambs with all new hardware, demoing existing doors and installing new. Total \$ 10,240.45

Demoing the existing 305 sf of concrete next to building and in front of main door and forming up and pouring back in #4000 limestone. Total \$ 4,964.20

Fixing all holes in mortar joints and painting exterior back and one side of building. Total \$ 3,186.74

~~Bring in approx 15 ton of crushed asphalt and making a 20'x20' parking pad instead of gravel. Total \$ 2,114.63~~

Recaulking 9 exterior windows. \$ 298.70

~~Purchasing new 20' aluminum flag pole and installing in front of building, not a cheap one either. \$ 1,825.09~~

Fixing ceiling inside main entry and in back, recaulking crown mold and painting entire inside of building except for restroom and offices, painting front reception area below countertop and 4 door's and set of bi-fold door's in a gray color with the rest being painted white. Total \$ 7,146.53

Flooring MDs Carpet One
 PO Box 204
 North Sioux City, SD 57049 US
 6057803567
 flooringmds@gmail.com

Estimate

ADDRESS
 Kenny
 Woodbury County Courthouse
 620 Douglas St.
 Sioux City, IA 51101 USA

SHIP TO
 Kenny
 Woodbury County Courthouse
 620 Douglas St.
 Sioux City, IA 51101 USA

ESTIMATE #	DATE	EXPIRATION DATE
1871	08/22/2025	09/22/2025

P.O. NUMBER
 Anthon Courthouse

SALES REP
 Linny

DATE	ACTIVITY	DESCRIPTION	QTY	RATE	AMOUNT
	Carpet Tile	Impromptu - At First Glance Material Only	671.76	4.12	2,767.65
	Install	Install Product Purchased - Carpet Tile	671.76	1.25	839.70
	Adhesive	Nexus Modular Adhesive	1	169.00	169.00
	Trim	Rubber Reducer	24	1.65	39.60
	Furniture	Move and reset furniture	1	500.00	500.00
	Freight	Shipping Charge	1	300.00	300.00
	Covebase	Covebase, adhesive, & install - TBD	170	2.59	440.30
	mileage	Mileage x 4	163.20	0.65	106.08
	Tear Out	Tear out of existing flooring - carpet tile	635	0.25	158.75

We offer interest free financing with no down payment!
 Estimate pricing is good for 7 days.
 Floor prep is not included in the estimate.
 If carpet is being installed, the walls may need to be touched up after installation is complete.
 We require a 75% down payment before product is ordered.
 There will be a late fee of 1.5% applied if not paid within 30 days.

SUBTOTAL 5,321.08
TAX 0.00
TOTAL **\$5,321.08**

Accepted By

Accepted Date

By signing this document, the customer agrees to the services and conditions outlined in this document.
 If or when a down payment is made, that will take the place of the signature and the client will be responsible for all monies owed.
 If there is an issue, Flooring MD's Carpet One has first option to fix any and all concerns.

City of Sioux City, Iowa
FY 2027 – 2031 Capital Improvement Program

Work Plan:

	City Share	County Share	Total
<u>FY 2026</u>			
Enterprise/Edge Firewall Upgrade	\$100,000	\$100,000	\$200,000
Security Utilities/Keys	60,000	40,000	100,000
County PCs	-	40,000	40,000
Fiber Optics	25,000	25,000	50,000
Fiber Testing & Diag Tools	25,000	25,000	50,000
GIS Dashboard	25,000	25,000	50,000
Extreme Edge Switch Cleanup	25,000	25,000	50,000
Total	\$260,000	\$280,000	\$540,000

	City Share	County Share	Total
<u>FY 2027</u>			
Hyper-Converged Infrastructure Refresh ¹	\$500,000	\$500,000	\$1,000,000
County Multifunctional Printers & PCs	-	100,000	100,000
Fiber Remediation	25,000	-	25,000
CCAT/Orpheum/Longlines Wireless	25,000	-	25,000
Total	\$550,000	\$600,000	\$1,150,000

	City Share	County Share	Total
<u>FY 2028</u>			
VMWare Infrastructure Refresh	\$100,000	\$100,000	\$200,000
AI	50,000	50,000	100,000
Fiber Optics	25,000	25,000	50,000
EVMS Refresh	40,000	40,000	80,000
PC's & Laptops	-	90,000	90,000
Total	\$215,000	\$305,000	\$520,000

	City Share	County Share	Total
<u>FY 2029</u>			
Access Point Replacement	\$110,000	\$100,000	\$210,000
iSeries Upgrade	60,000	60,000	120,000
Backups	50,000	50,000	100,000
PC's Laptops	-	200,000	200,000
Total	\$220,000	\$410,000	\$630,000

	City Share	County Share	Total
<u>FY 2030</u>			
Core Switches	\$175,000	\$175,000	\$350,000
Fiber Ring Upgrade	40,000	40,000	80,000
O365 Backup	30,000	30,000	60,000
Scanners	30,000	45,000	75,000
Total	\$275,000	\$290,000	\$565,000

	City Share	County Share	Total
<u>FY 2031</u>			
Edge Switches	\$250,000	\$170,000	\$420,000
iSeries	60,000	60,000	120,000
Telco	80,000	40,000	120,000
Total	\$390,000	\$270,000	\$660,000

¹Project amount increased due to significant price hikes that occurred after the original submission.

Scoring Matrix:

Strategic Plan	2	Public Benefit/ Demand	1	Economic Development	0
Mandates/Obligations	0	Coordination	1	Feasibility	2
Services	1	Efficiency/ Budget Impact	1	Opportunity Cost	1
				Total	9

**City of Sioux City, Iowa
FY 2027 – 2031 Capital Improvement Program**

Project Name: WCICC Information Services Upgrade

Project Number: 859-006
Project Manager: John Malloy
TIF District: None

CIP Score: 9
Current CIP Cost: Annual
Start Date of Project: Annual

	FY 2026 Approved Budget	FY 2027 Requested Budget	FY 2028 Requested	FY 2029 Requested	FY 2030 Requested	FY 2031 Requested	Unprogrammed
Woodbury County	280,000	550,000	305,000	410,000	290,000	270,000	-
General Obligation Bonds	260,000	500,000	215,000	220,000	275,000	390,000	-
Total Revenues	540,000	1,050,000	520,000	630,000	565,000	660,000	-
Other Capital Improvement	540,000	1,050,000	520,000	630,000	565,000	660,000	-
Total Expenditures	540,000	1,050,000	520,000	630,000	565,000	660,000	-

Description/Justification: This project represents a strategic investment in Information Technology infrastructure, strengthening the foundation that supports essential Public Safety and Public Administration systems while positioning the organization for future demands.

Relationship to Other Projects: None.

Additional Financial Information: CIP 859-006 is split between projects 859-041 (City), 859-042 (County) and 852-005 (County PC Replacement) at the beginning of the fiscal year.

Effect on Operating Budget: None.

Relationship to Strategic Plan: This project is directly supported by the Internal Goals Strategic Focus Area "Pursue new technology platforms to increase efficiency," and the Health and Safety Municipal Responsibility, "We will enhance public health and safety by maximizing the utilization of technology, improved community engagement, and improved communications and facilities."

Cash Balance: \$0

Year End Expected Balance: \$0

WOODBURY COUNTY AGENDA ITEM(S) REQUEST FORM

Date: 5/6/2026 Weekly Agenda Date: 5/12/2026

Elected Official / Department Head / Citizen: Kenny Schmitz

Wording for Agenda Item:

Communications Services backup Site located at Woodbury County Climbing Hills have highlighted the need to identify a future replacement location. E911 Communication's representatives Wendi Hess (Director) / Travis Cipperley (Operations Supervisor) will discuss challenges relating to the current backup site for E911. Site replacements have been reviewed & the Woodbury County Law Enforcement Center has been a facility that would meet the necessary requirements. Woodbury County Sheriff Chad Sheehan & Woodbury County Building Services Department Director Kenny Schmitz have had meetings on-site with Communications Services. The initial meeting on site discussed shelled space opportunity & possibility of a construction project. Follow up meetings discussed Comm Center employee facility access. Communication Center contractors were present regarding their input on specific specialized systems, inter-connectivity, installations, & eventual price quotes.

Action Required:

Approve Ordinance

Approve Resolution

Approve Motion

Hold Public Hearing

Informational

Attachments

Set Time:

Reviewed by County Attorney's Office:

Background & Financial Impact:

Challenges relating to the current backup site for E911 Services located at Woodbury County Climbing Hills location have highlighted the need to identify a new backup site location for E911. Communications Services will discuss relative financial goals.

Recommendation:

Consideration & motion to approve an E911 Communications backup site to be located at the Woodbury County Law Enforcement Center Lower Level

Attachments:

[E911 Backup Site Operations](#)

Approved by Board of Supervisors on March 17, 2026

**To: LEC Authority
Woodbury County Board of Supervisors**

From: Wendi Hess, Communications Director

Date: May 1, 2026

RE: Backup Site Operations Exercise Summary- October 29, 2025

Summary:

- On October 29th the Communication Center practiced its evacuation plan by moving operations to Woodbury County Emergency Services in Climbing Hill where the alternate dispatch location is housed. Shifts worked in Climbing Hill from 0545-1000; 1000-1400, 1400-1800, 1800-2200 and 2200- midnight.

Challenges:

- 1) **Network/IT:** The Motorola Flex dispatch system experienced significant lag and eventually froze. IT personnel were called to investigate. Initially, it was believed that a software update was required, but the slow network connection at the backup site prevented successful download. The root cause was later identified as a firewall rule. Once discovered, the issue was resolved, though the troubleshooting process took approximately two hours.
- 2) **StateLink:** Dispatch staff were unfamiliar with using Flex StateLink for Iowa System/NCIC inquiries. Although the program has been available for several years, most staff rely on CommSys Clips for these functions and have not been required to use StateLink regularly.
- 3) **Display Settings:** The screen resolution at the backup site was noticeably smaller than what staff are accustomed to, impacting visibility.
- 4) **Temperature:** The room temperature was uncomfortably cold.
- 5) **Radio:** No access to R3CALL31 to receive radio traffic from other Iowa agencies. The County Fire position foot pedal did not work for transmitting.
- 6) **MACH:** MACH system could not be used due to insufficient network speed, restricting access to messaging and tracking units.

Positives:

- 1) **Network Printer Access.** Staff were able to connect to and use network printers without any issues, supporting seamless document handling during the exercise.
- 2) **Clear Radio Communications.** User agencies reported no degradation in audio quality. Radio traffic from the backup site was as clear and reliable as transmissions from the primary dispatch center.
- 3) **Effective Use of Flex StateLink.** Dispatchers successfully used the Flex StateLink system to send a hit confirmation and received the appropriate response, demonstrating operational proficiency with the tool.

- 4) **Secure System Access.** All staff logged into the backup site computers using their Yubi keys for multi-factor authentication and were able to perform their duties effectively.

After Action Items:

- 1) **Backup Site Location Distance:** The potential reasons for needing to evacuate the main 911 dispatch center could be related to severe weather conditions involving winter weather, requiring staff drive to Climbing Hill is less than ideal.
- 2) **Evaluate Backup Site Viability:** If network performance at the Climbing Hill site cannot be improved to ensure reliable access to the City/County computer network, it may be necessary to consider an alternative backup location. Any new site should meet the following criteria:
 - A dedicated room to support five dispatch workstations, each with a minimum of three monitors and sufficient power supply
 - A backup generator with an uninterrupted power supply (UPS)
 - Telephone access to allow forwarding of non-emergency calls
 - Adequate radio coverage and/or the capability to install external antennas
- 3) **Network/IT:** Coordinate with WCICC-IT to ensure that the backup location's computers receive proper support, and that any firewall modifications are addressed promptly to maintain system functionality.
- 4) **Enhance Radio Communication:** Install the R3CALL31 radio channel at the Channel 2 dispatch position to enable direct communication with other Iowa agencies and the State Patrol.
- 5) **Staff Training on StateLink:** Ensure all dispatch personnel are proficient in using StateLink within the Motorola Flex system for Iowa System/NCIC inquiries.
- 6) **Optimize Display Settings:** Review current screen resolution settings and explore whether adjusting font size in Flex can improve readability and usability.
- 7) **Provide Basic Comfort Items:** Equip the backup site with small but essential items such as trash cans and mouse pads to enhance the work environment.
- 8) **Address Temperature Control:** Since space heaters are not feasible due to electrical load limitations, alternative solutions for maintaining a comfortable room temperature should be explored.